

Crossing the river by feeling the stones.

simon.wardley@leadingedgeforum.com

Strategy

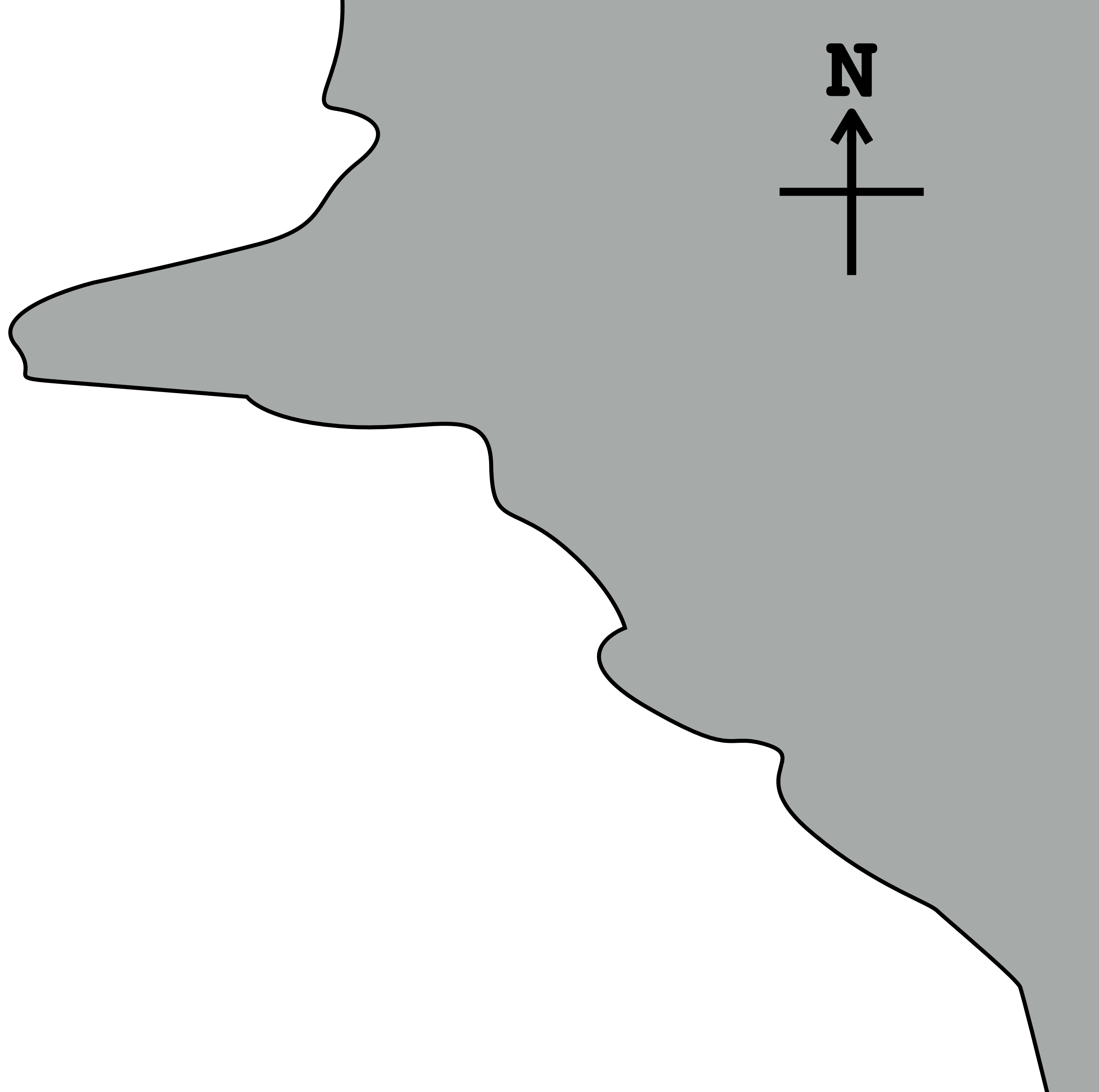

Strategy

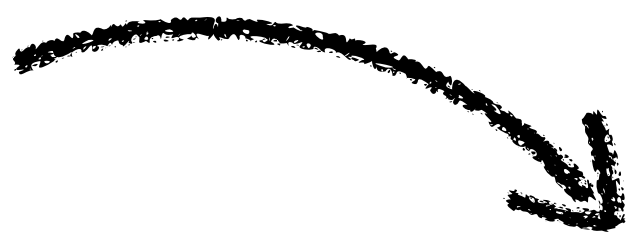

Maps

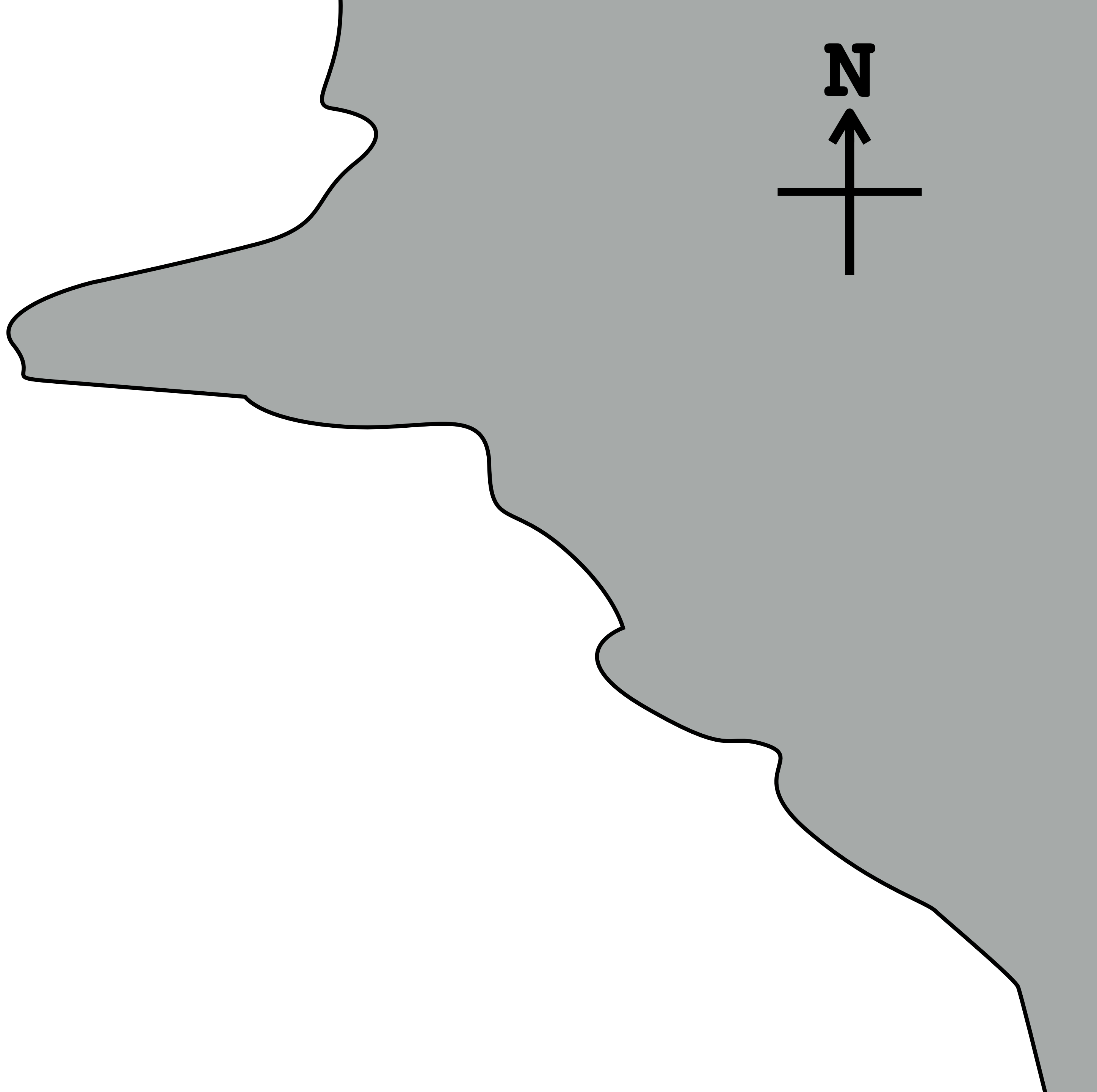

Strategy

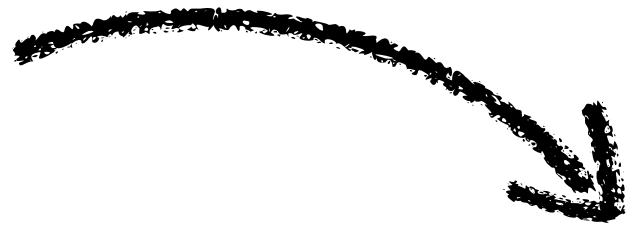

Maps

Communication

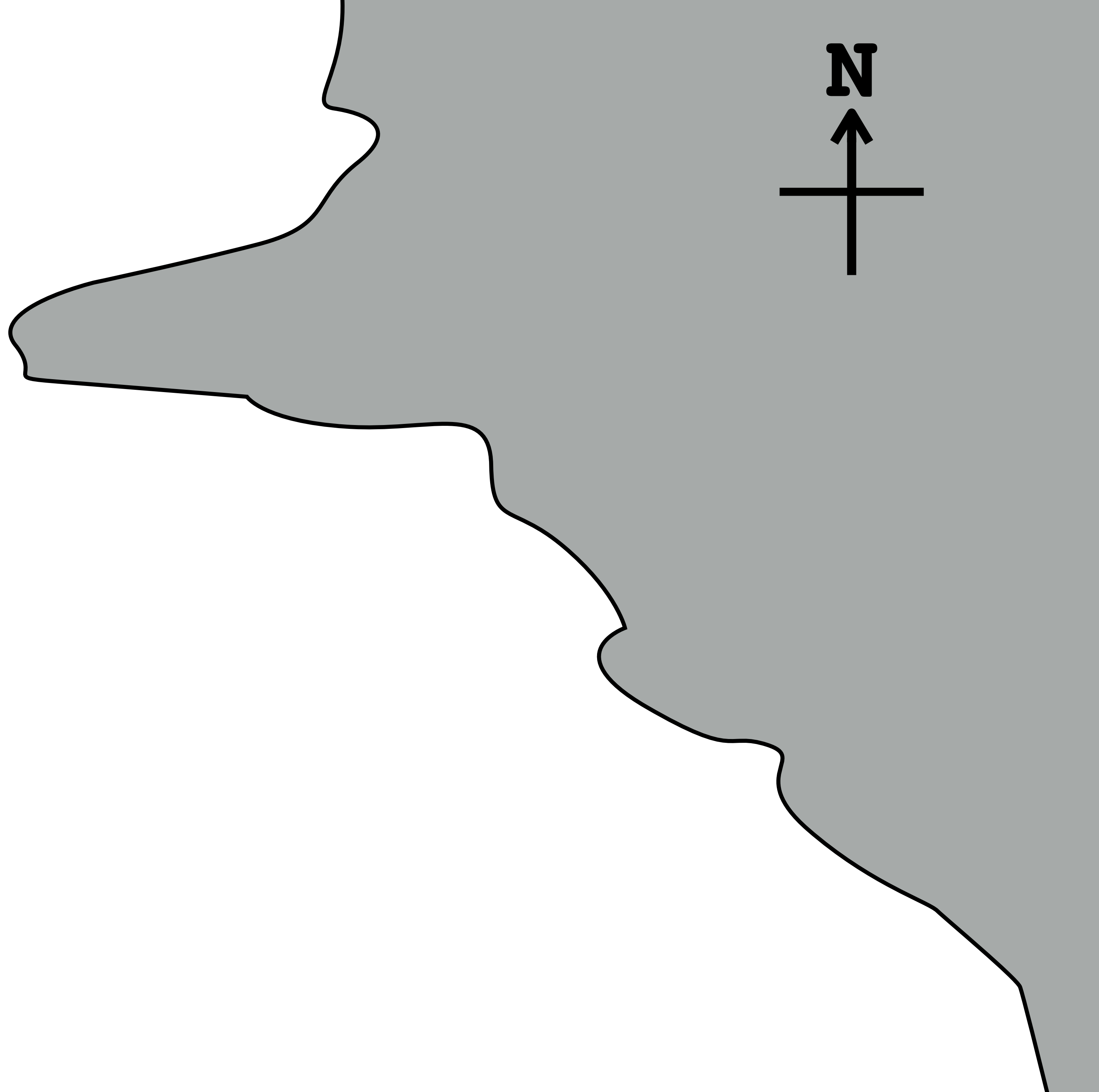

Strategy

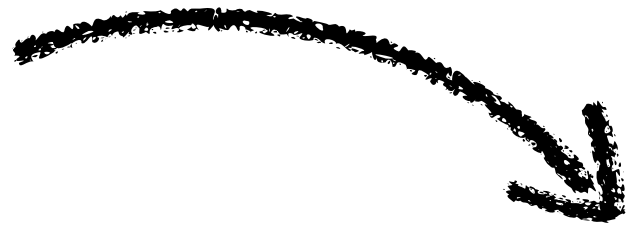

Maps

Communication

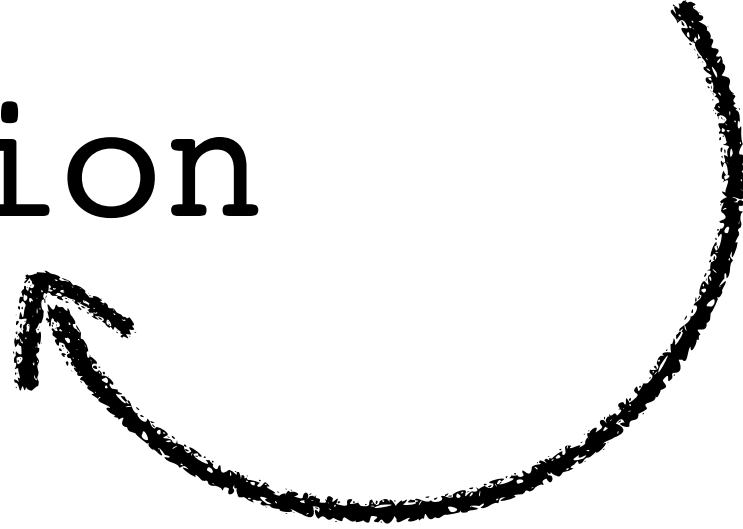

Patterns

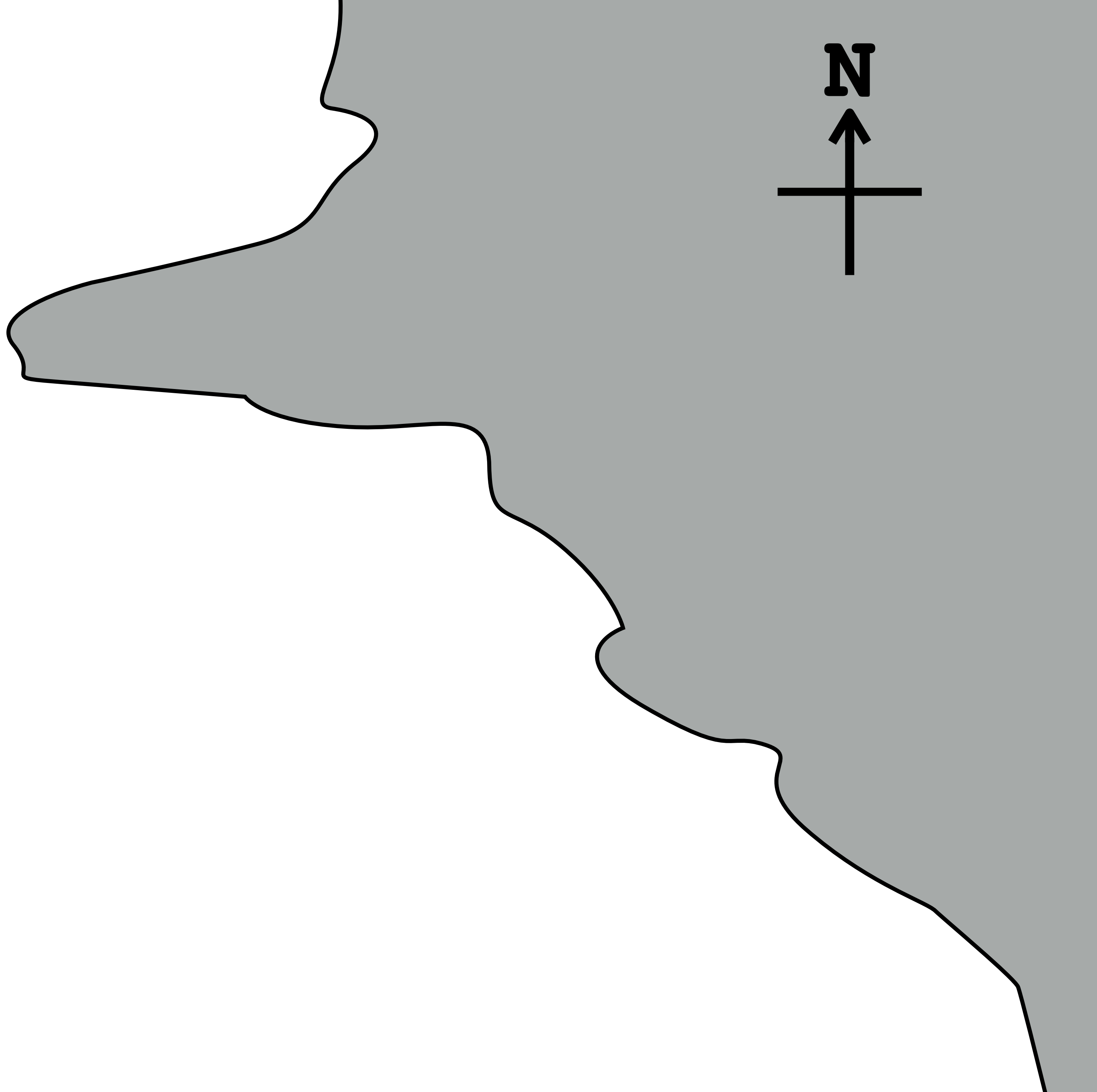

Strategy

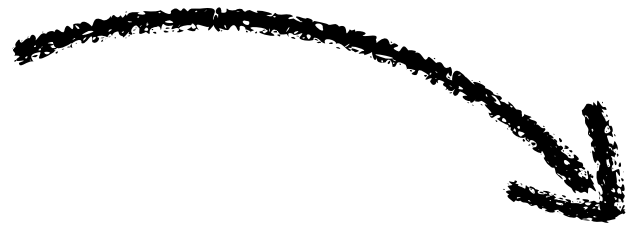

Maps

Communication

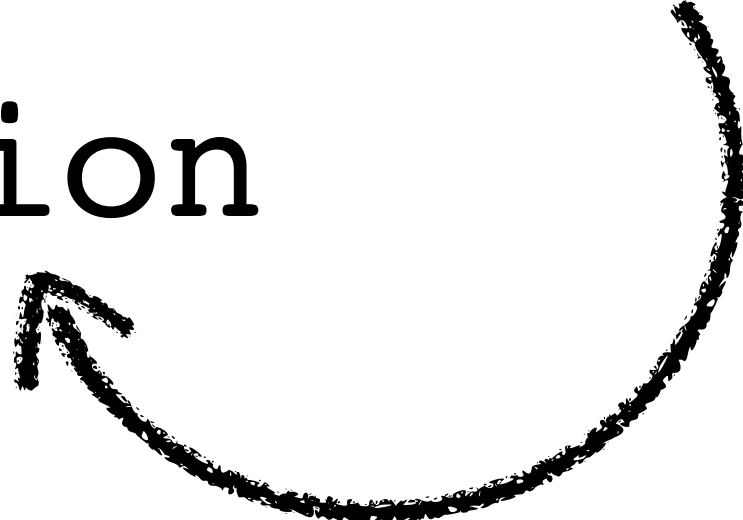

Patterns

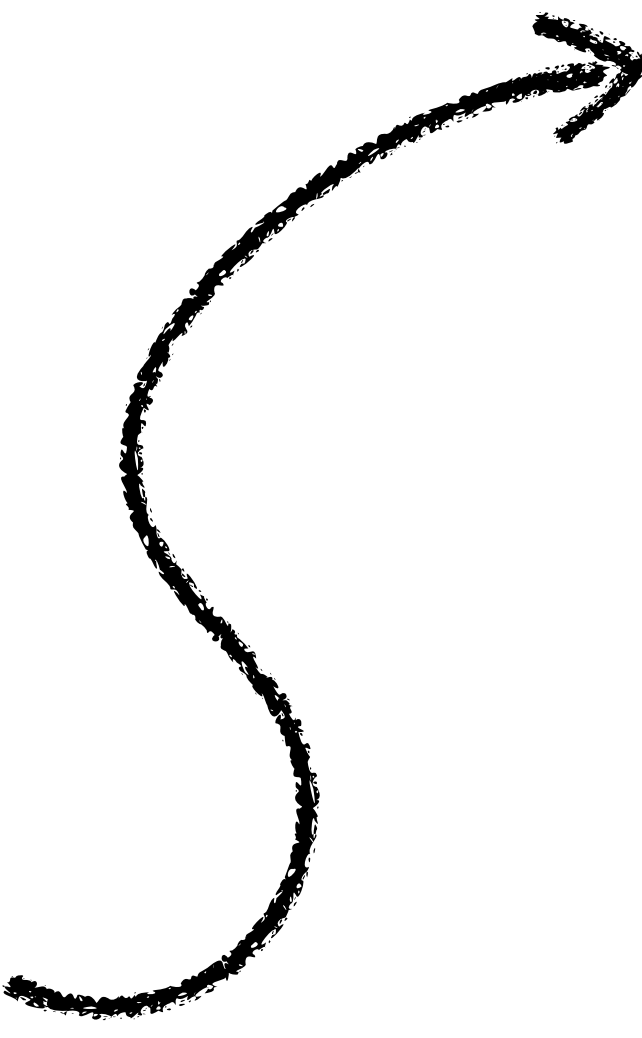

Anticipation

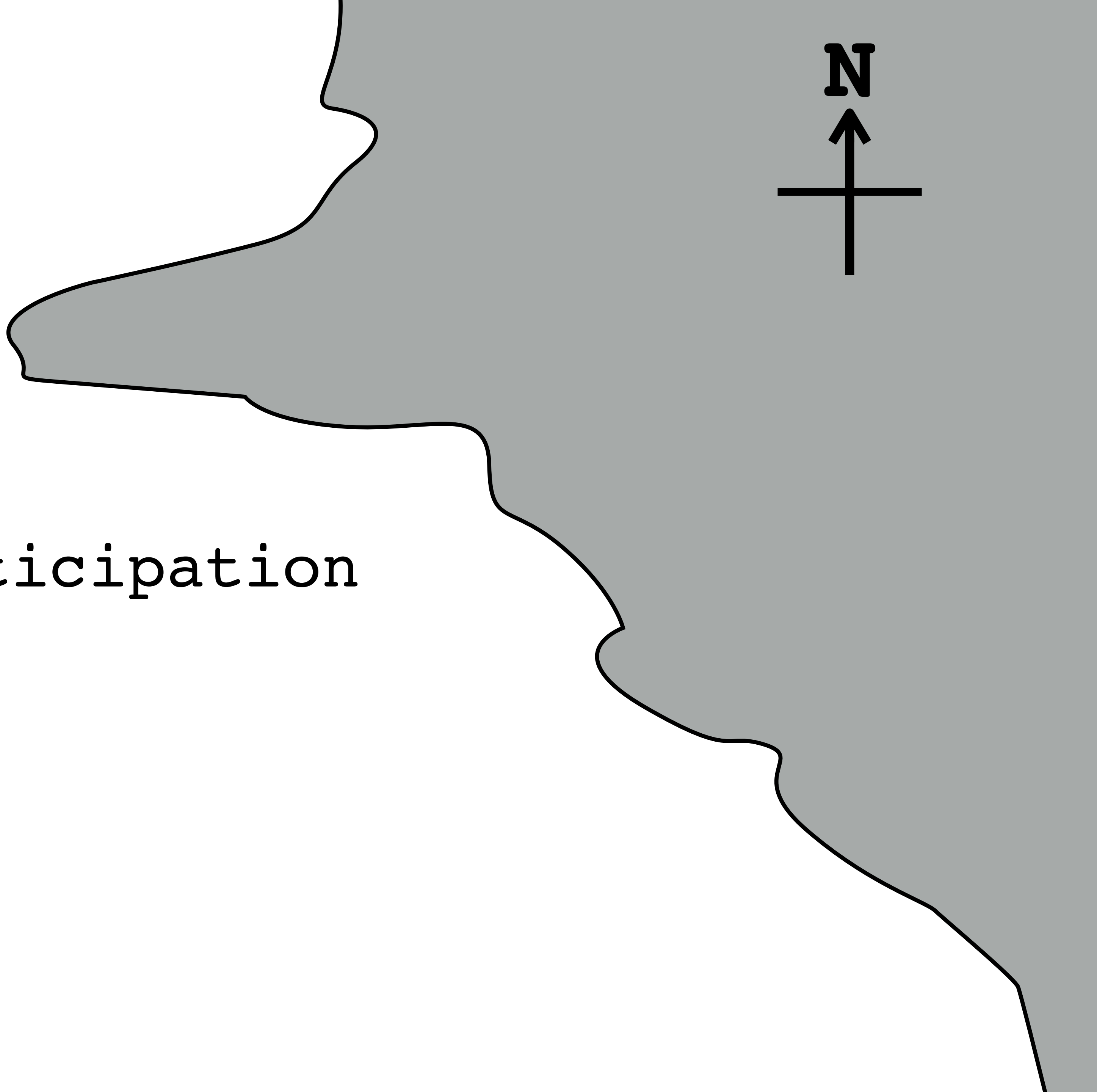

Strategy



Maps

Communication



Patterns

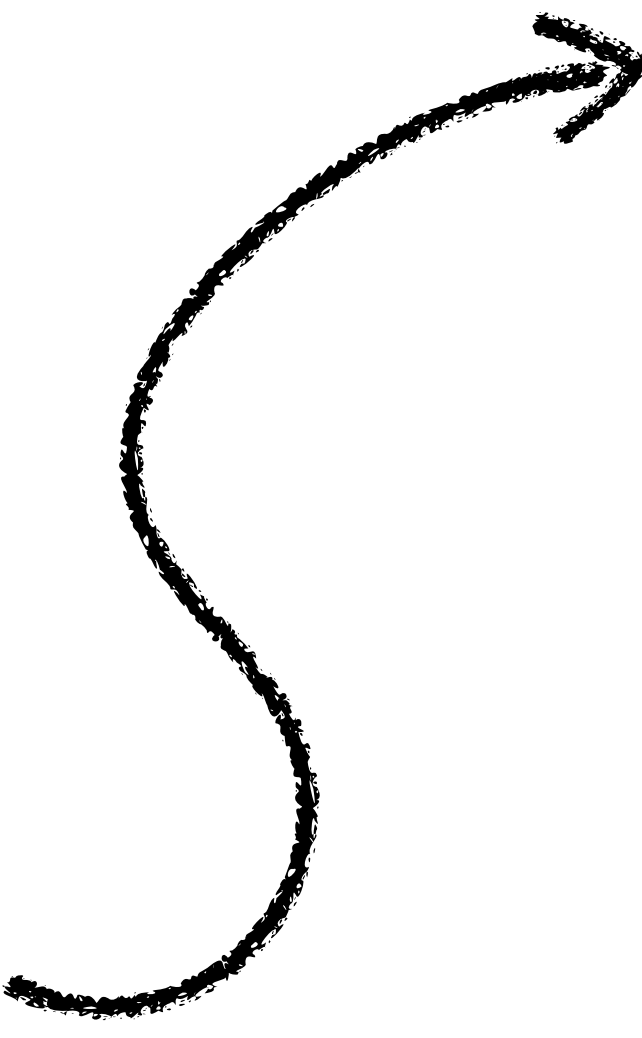

Anticipation

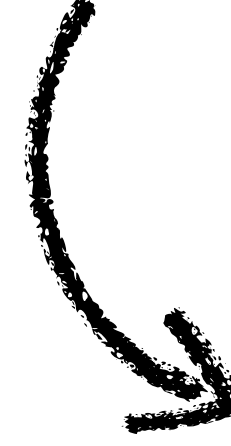

Organisation

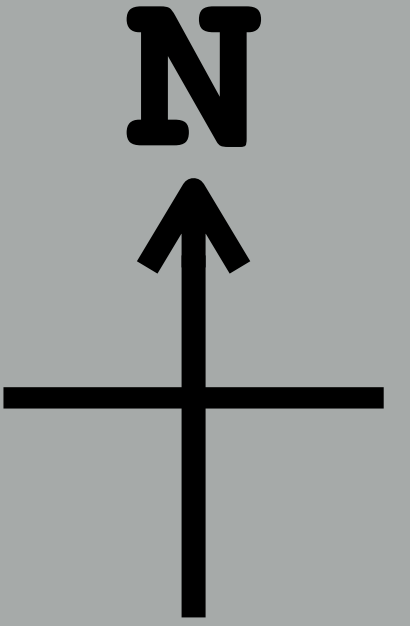
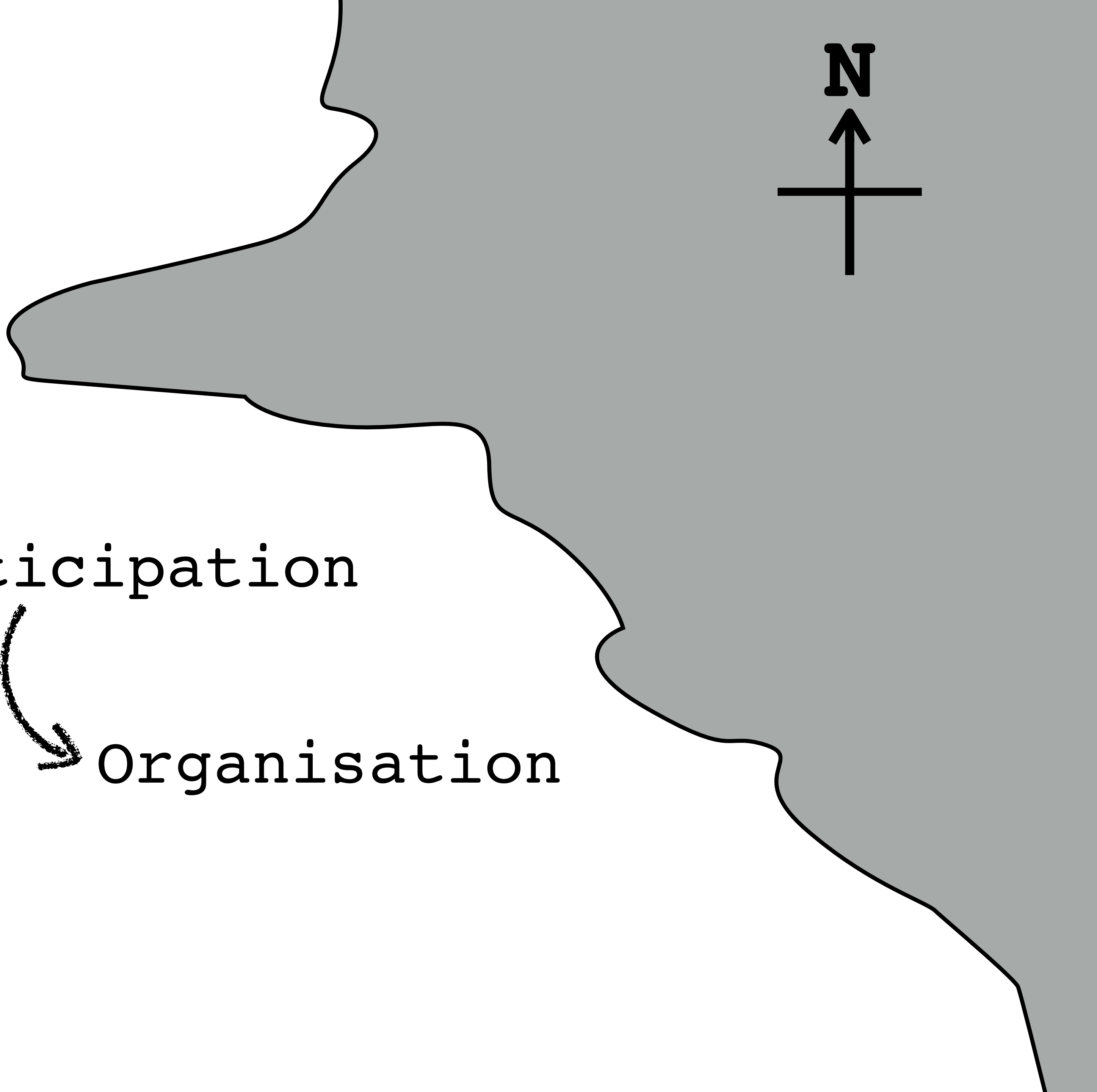

Strategy

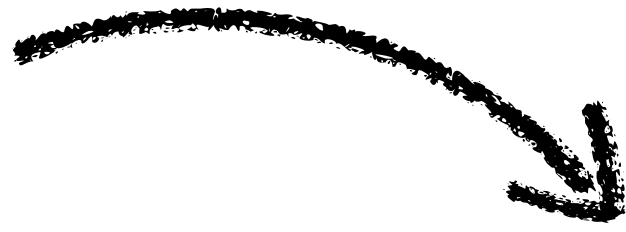

Maps

Communication

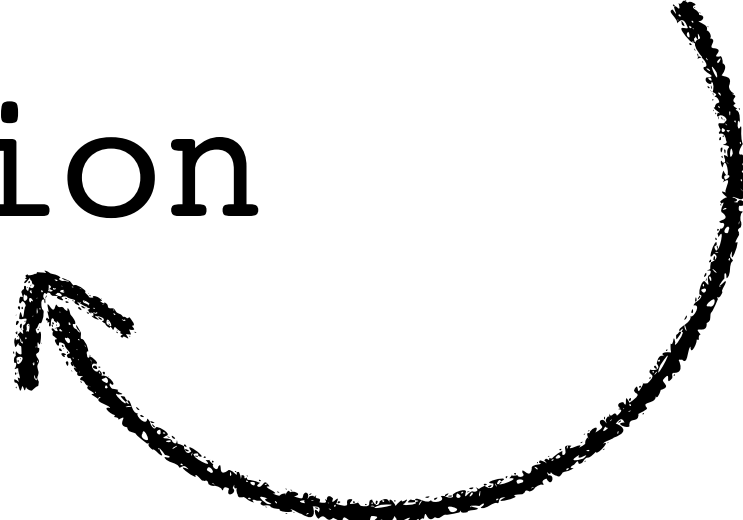

Patterns

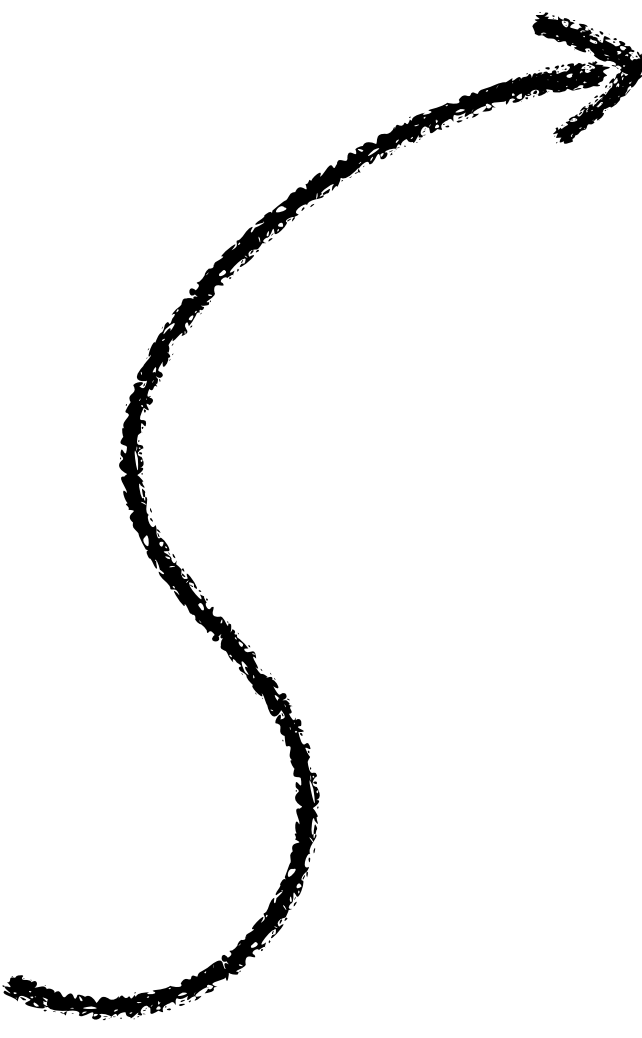

Anticipation



Organisation



Leadership

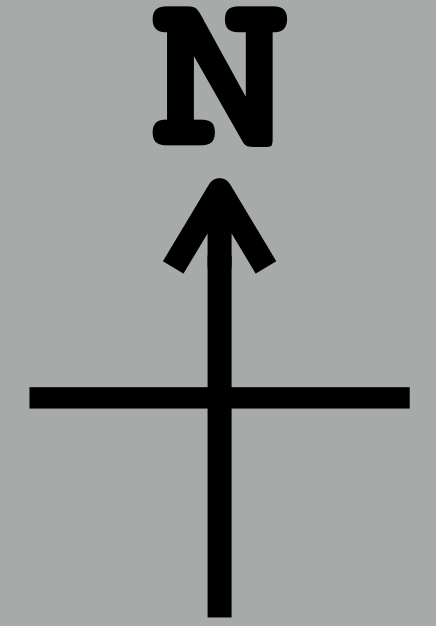
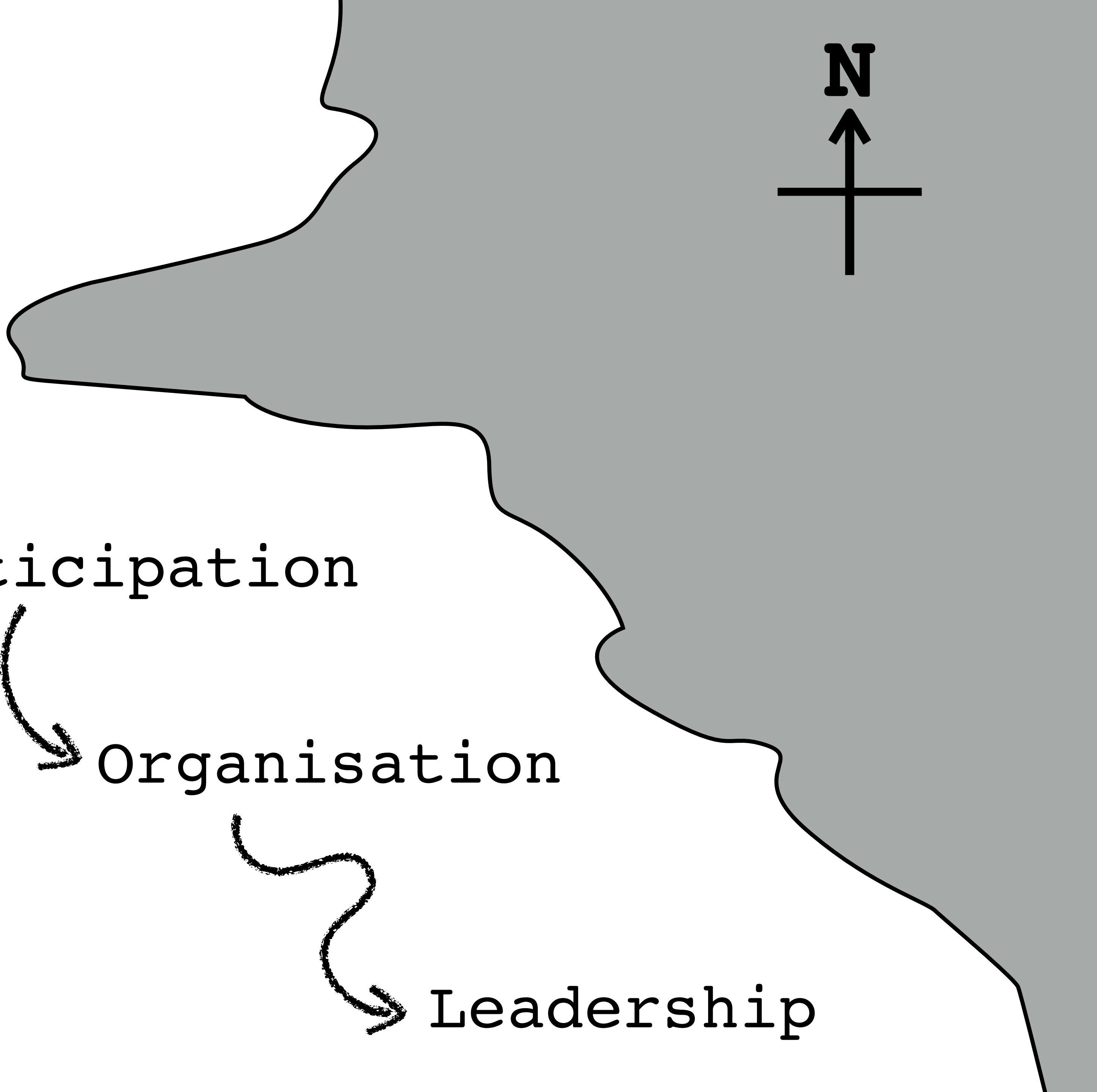

Strategy



Maps

Communication

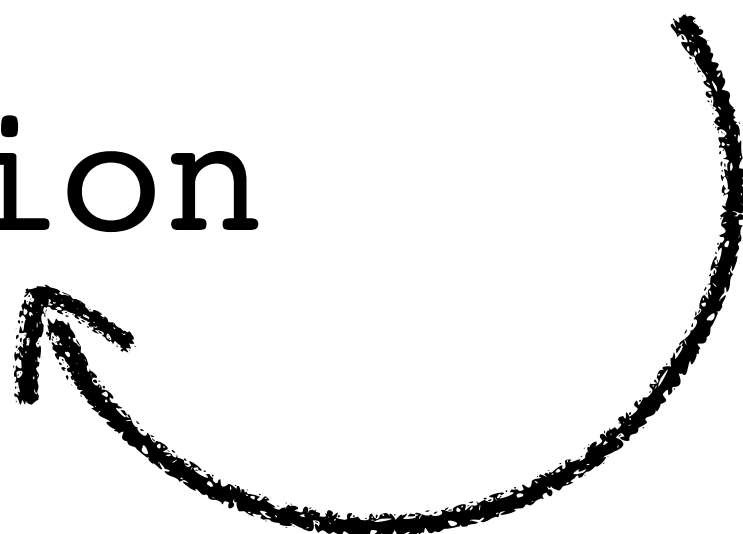

Patterns

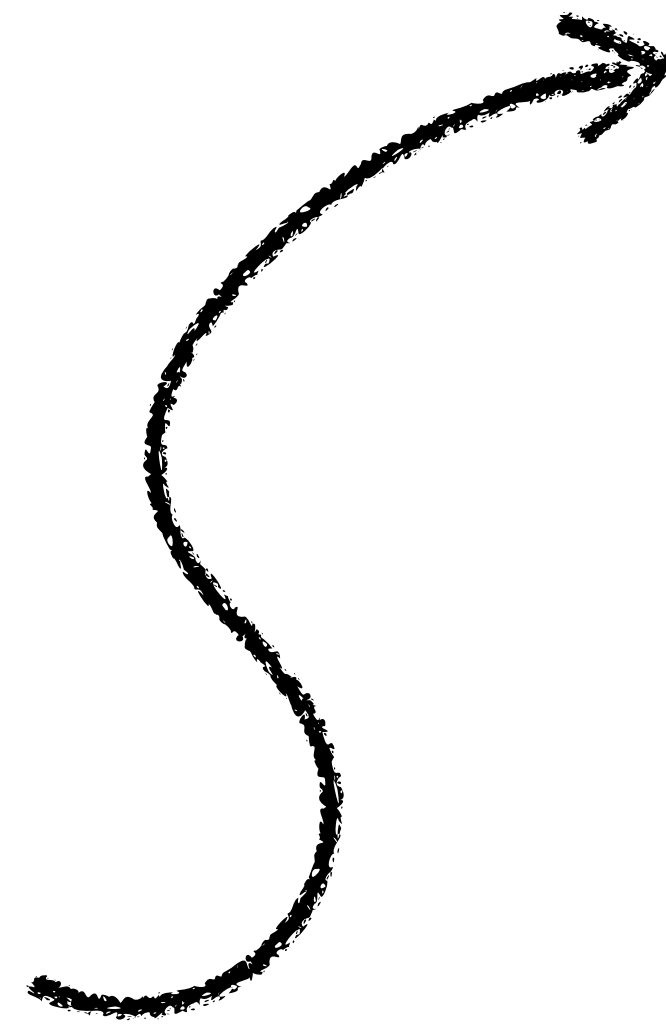

Anticipation



Organisation



Leadership

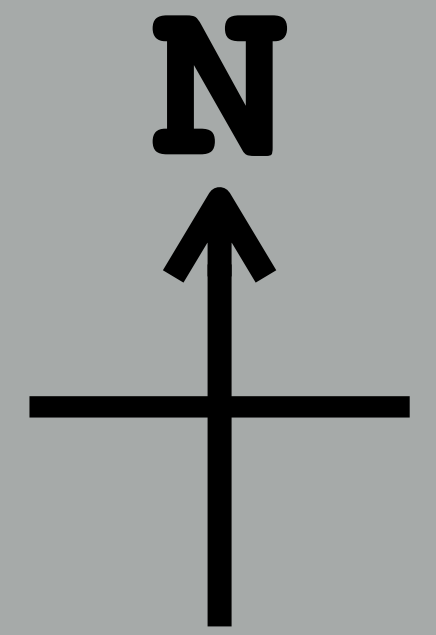

SERVERLESS



Strategy

Maps

Communication

SERVERLESS

Anticipation

Organisation

Patterns

Leadership

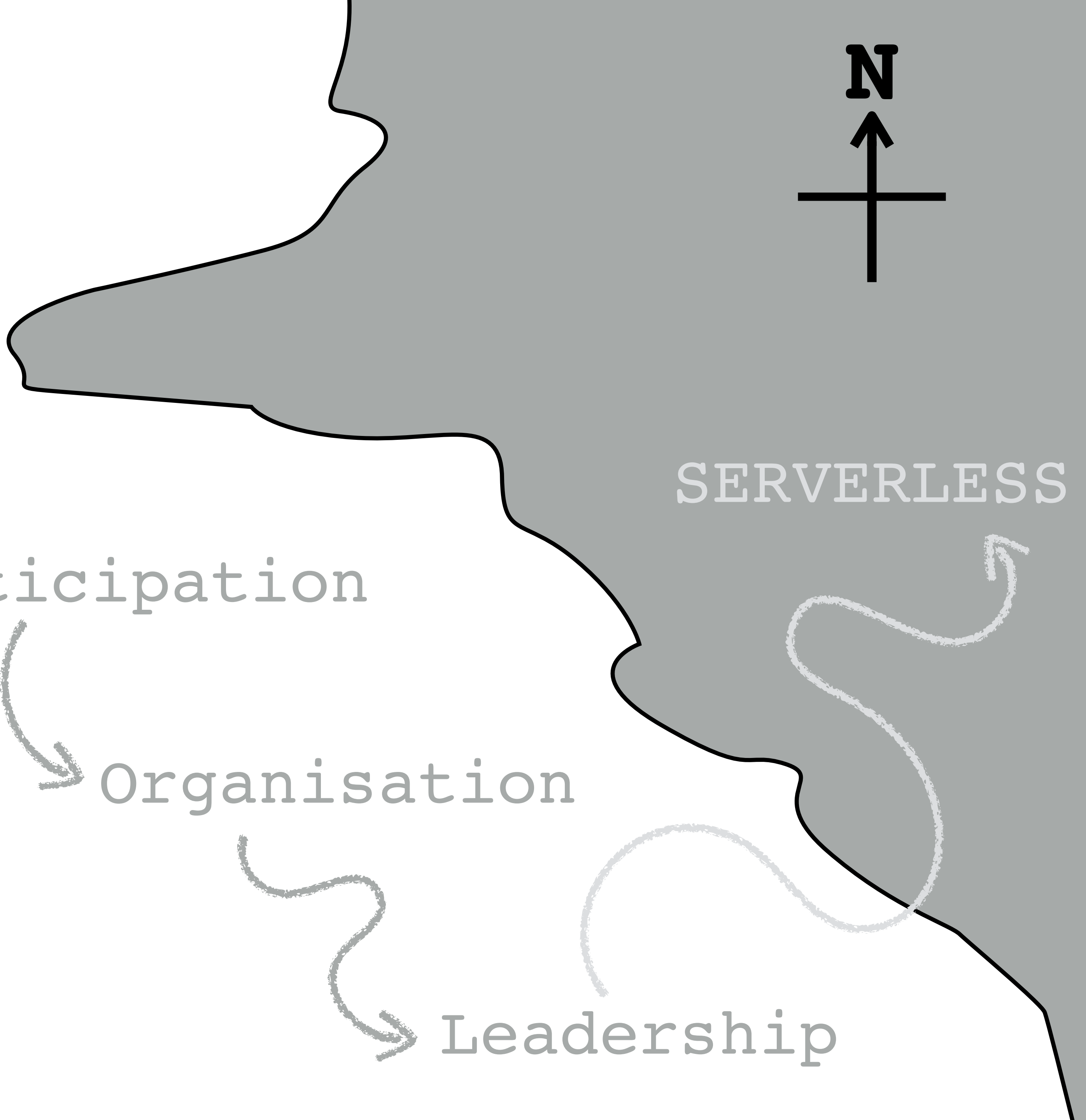
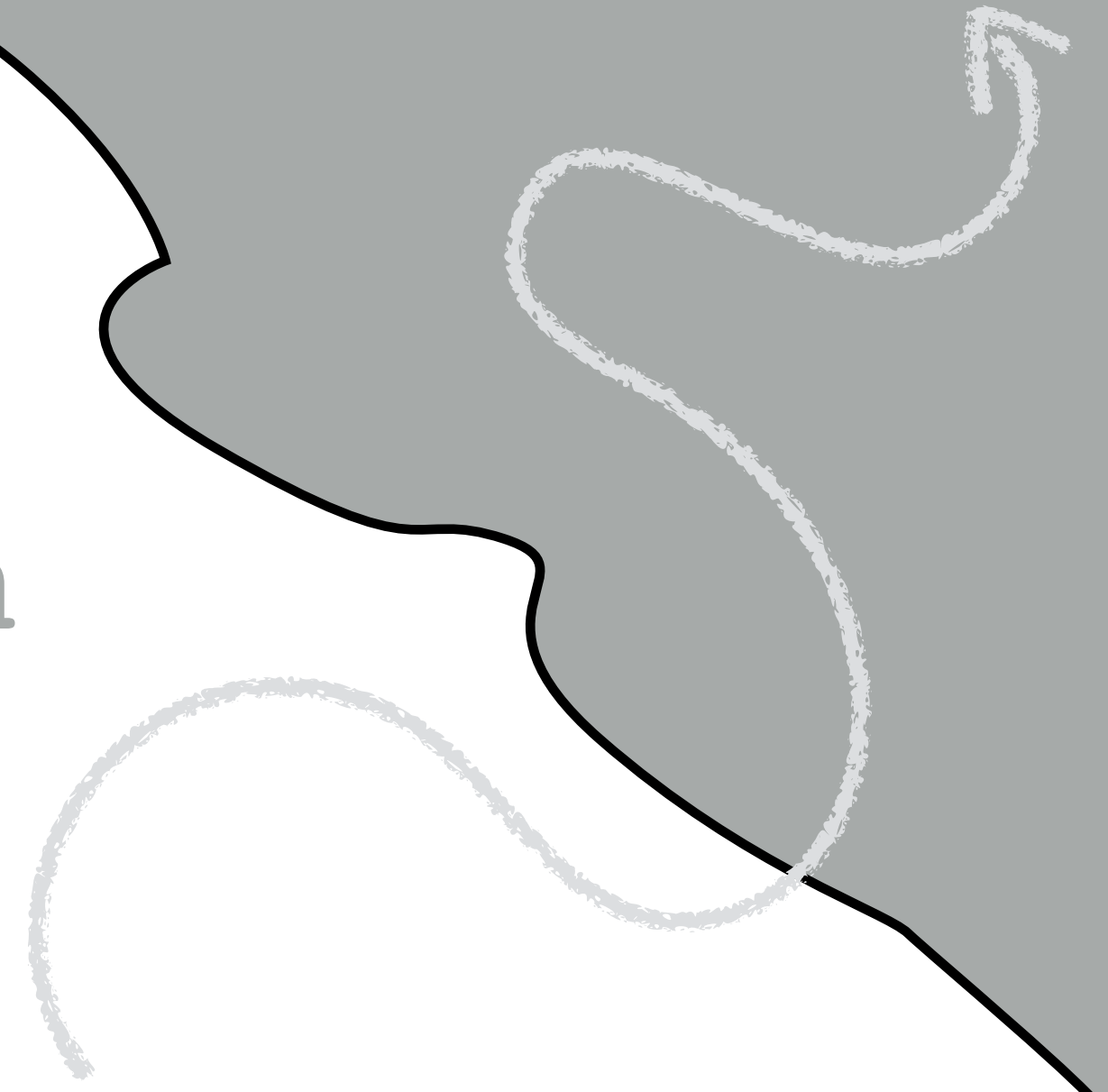
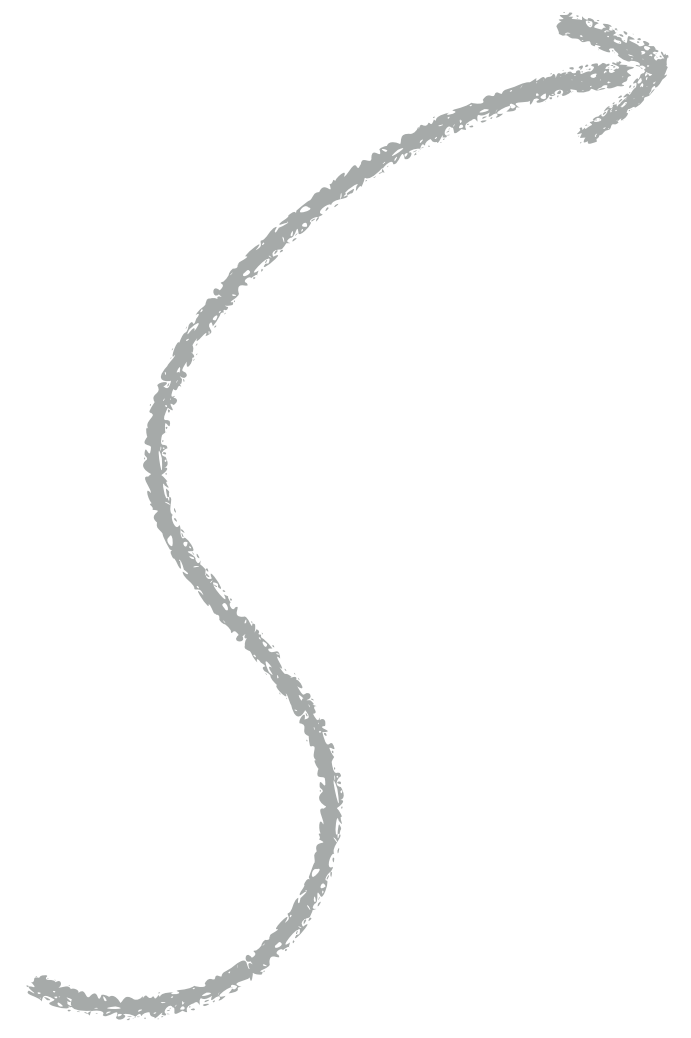
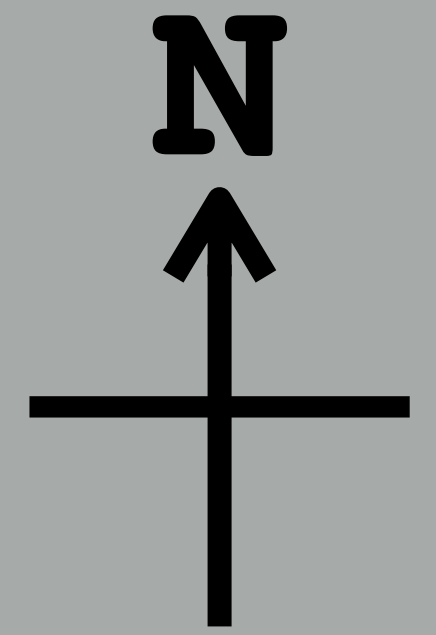



Top quality prints and a **FREE** online photo service

- **Digital and film**

Easy upload for digital pictures and film rolls

- **Create online albums**

Unlimited secure space for your pictures

- **Photo upload software**

Upload your images from your desktop

- **Share your photos**

Friends, family, workmates, share the moment

- **Buy prints and gifts**

Turn your favourite photos into great gifts

username

password

Login

[forgotten password?](#)

[Take the Tour](#)

[Create an account](#)

Gifts Gallery

Turn your photos into great gifts!



Promotions

Share pictures & when friend registers, you both get 3 free 6x4 prints.







FAAKE

CEO

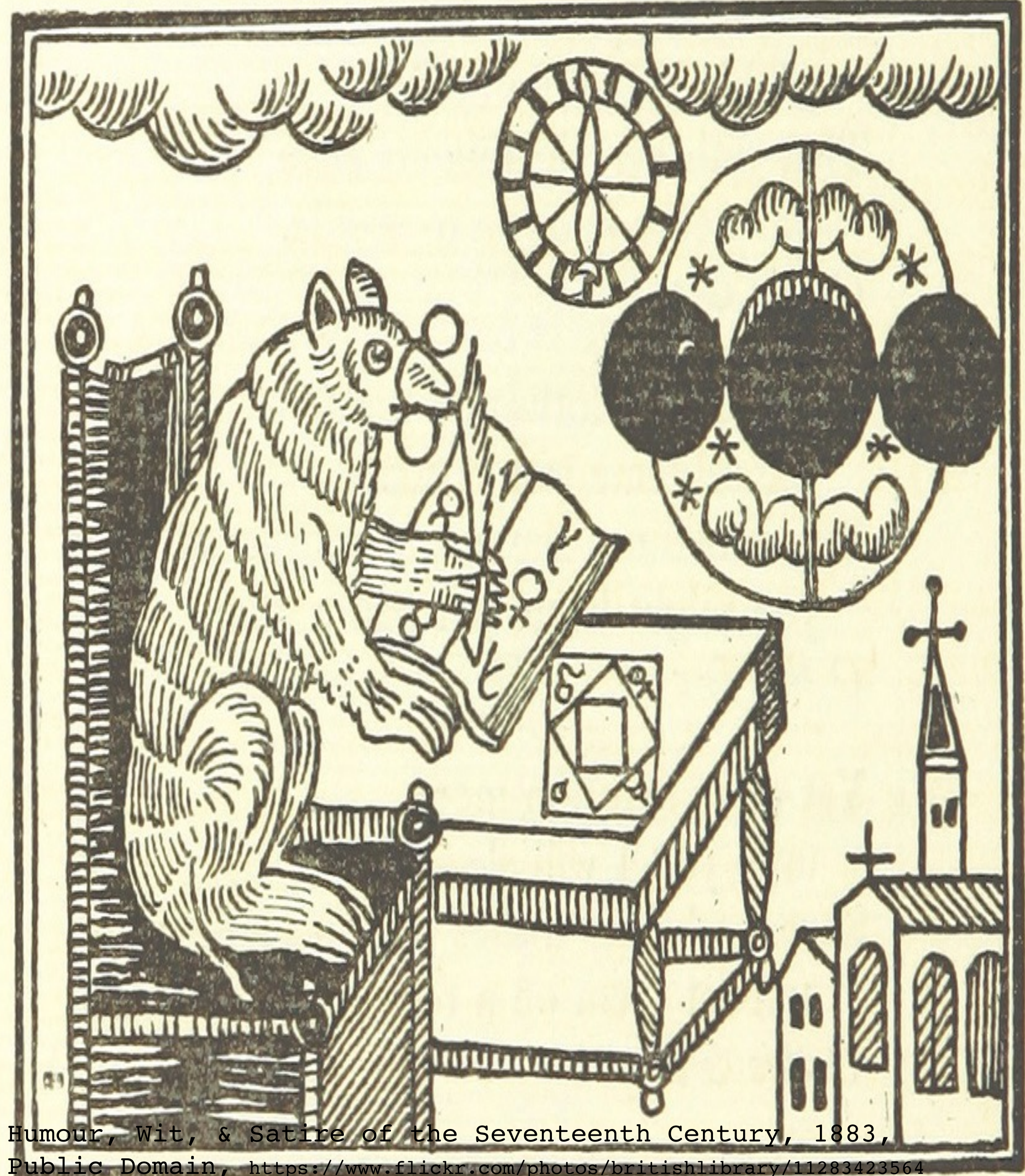

Navigation

Learning

Strategy

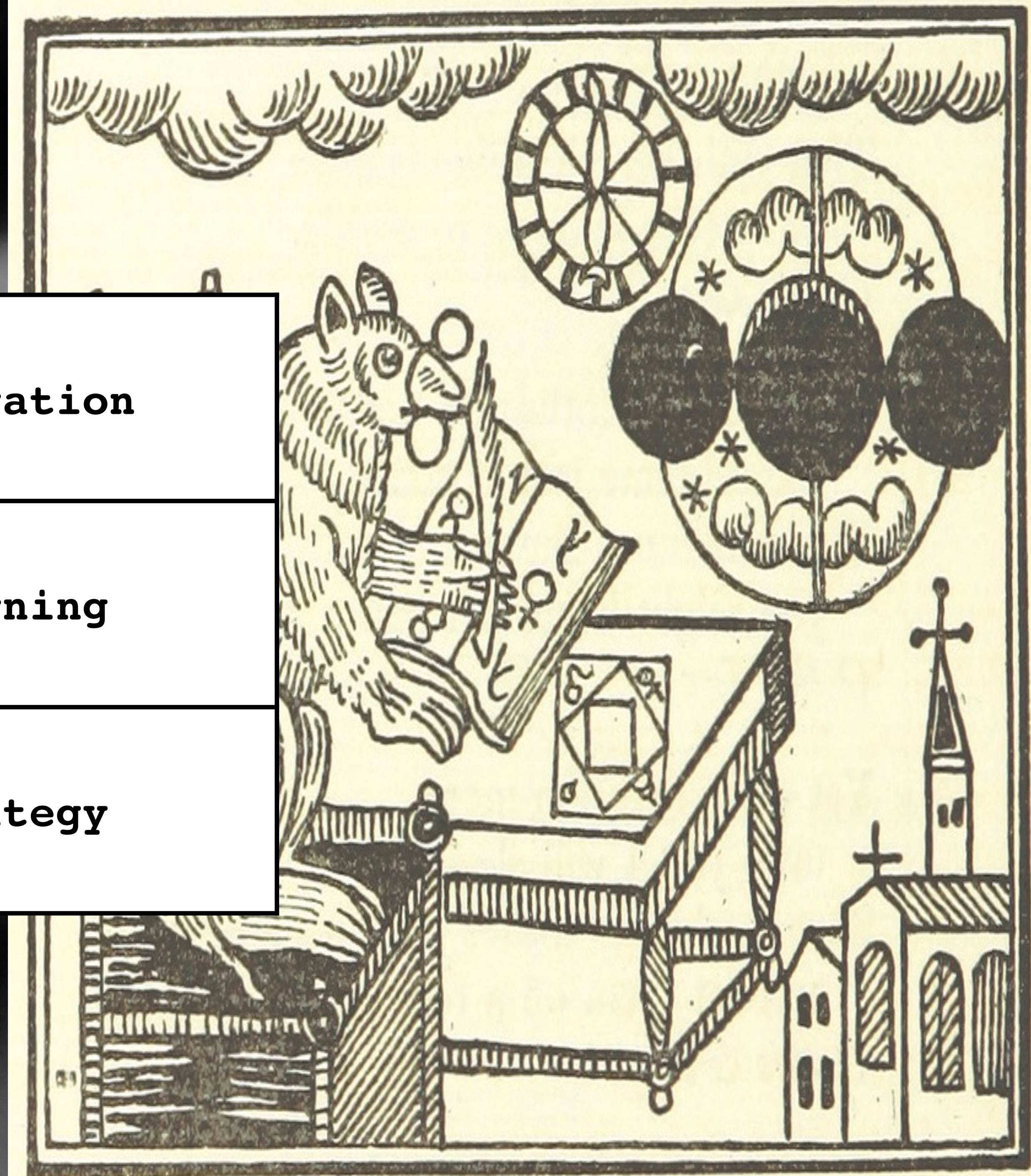

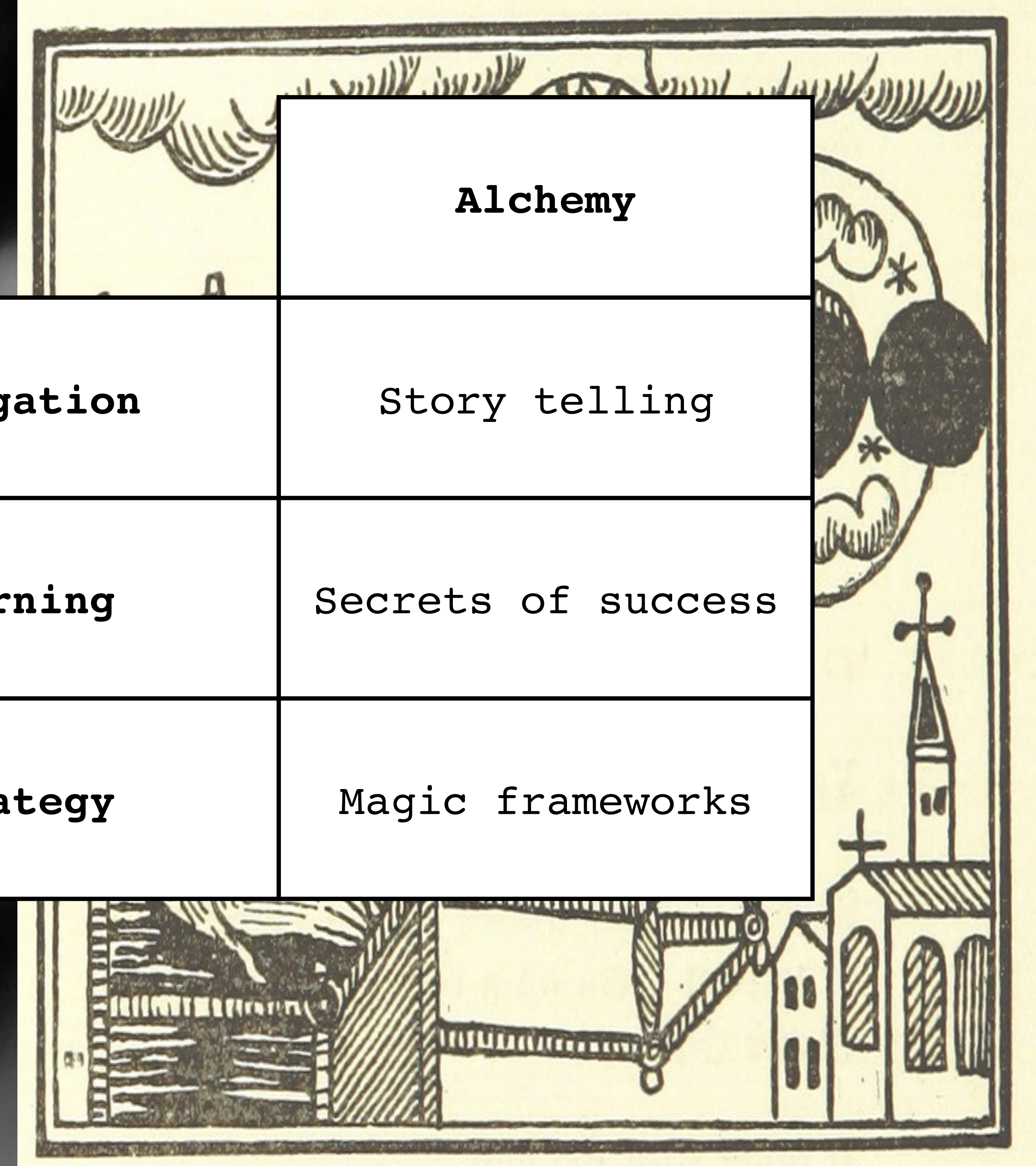
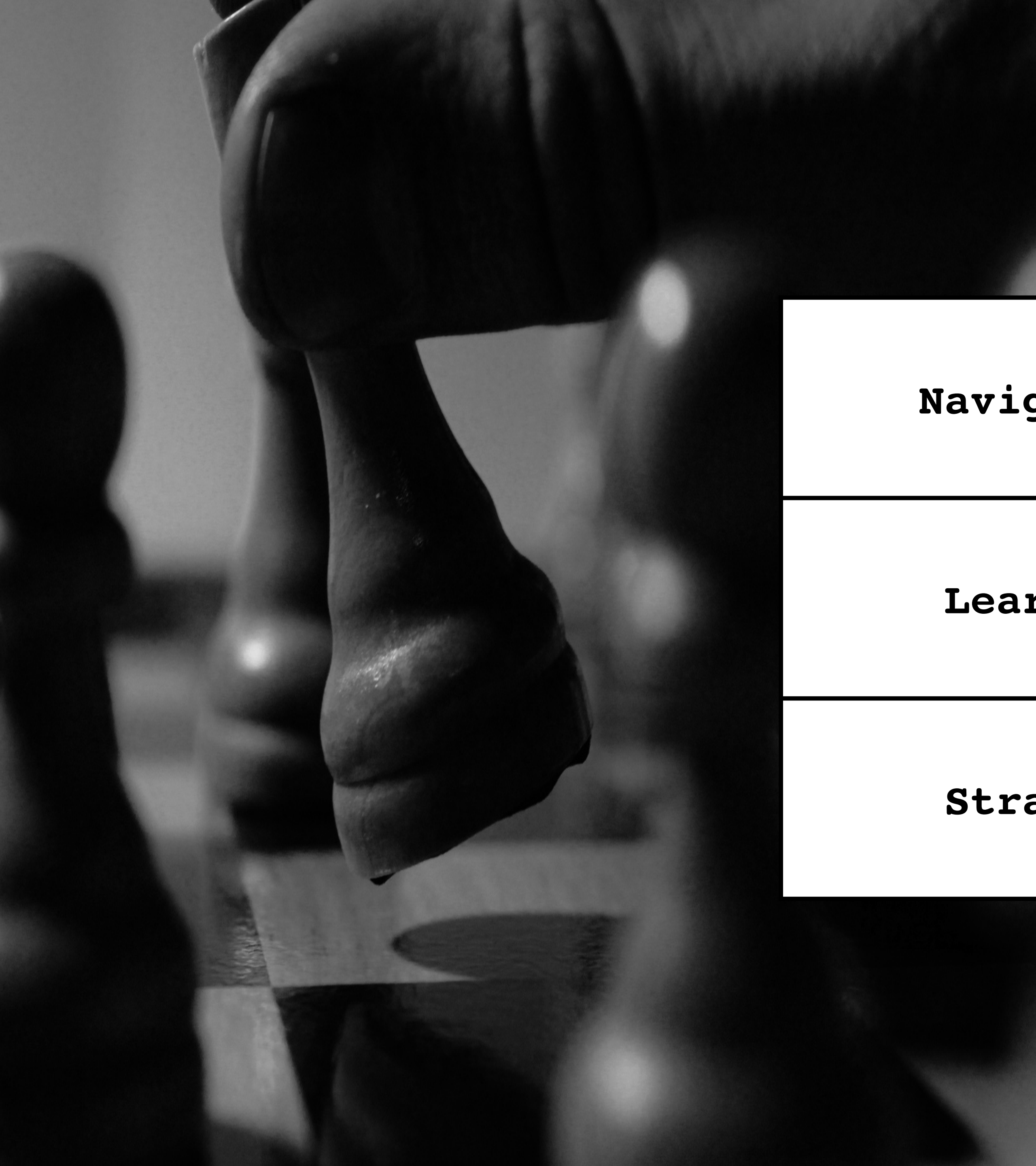

	Alchemy
Navigation	Story telling
Learning	Secrets of success
Strategy	Magic frameworks

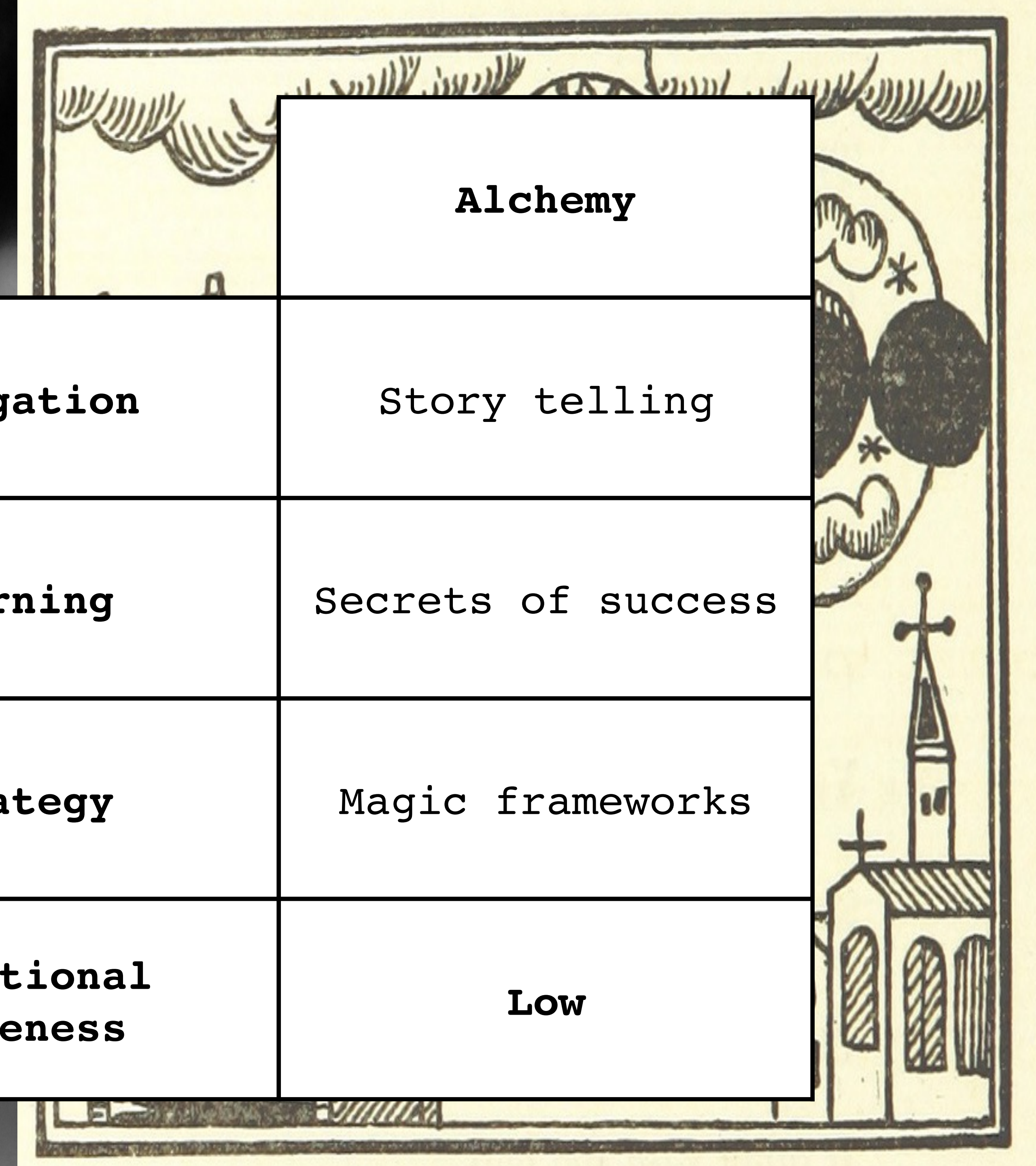
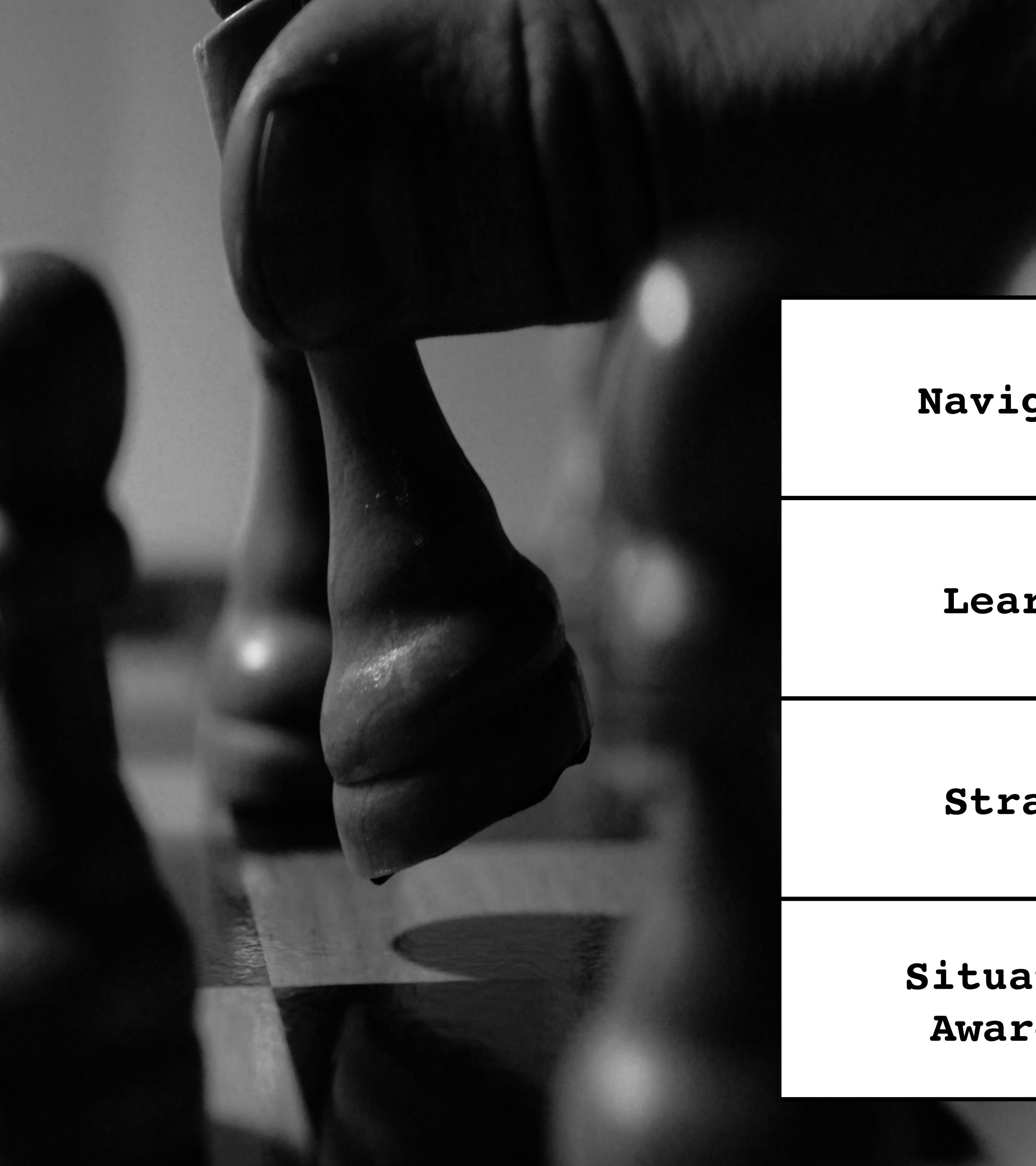

	Alchemy
Navigation	Story telling
Learning	Secrets of success
Strategy	Magic frameworks
Situational Awareness	Low

How Earlobes Can Signify Leadership Potential

by [Carl Senior](#), [Robin Martin](#), [Michael West](#), and [Rowena M. Yeats](#)

FROM THE NOVEMBER 2011 ISSUE



SAVE



SHARE



COMMENT



TEXT SIZE



PRINT



BUY COPIES

Evolutionary biologists have learned that people with greater “genetic fitness,” as manifested by a high degree of left-right body symmetry, are not just considered better looking but also tend to be healthier, more intelligent, and more dominant than others. They’re the classic alphas who rise to the top of rigidly hierarchical organizations such as the military.

But [our research](#) shows that people with subtle asymmetries—for example, imbalances in ear or finger length—are often better “transformational” leaders, able to inspire followers to put self-interest aside for the good of the group. Furthermore, teams they lead outperform teams whose leaders have more-symmetrical bodies.

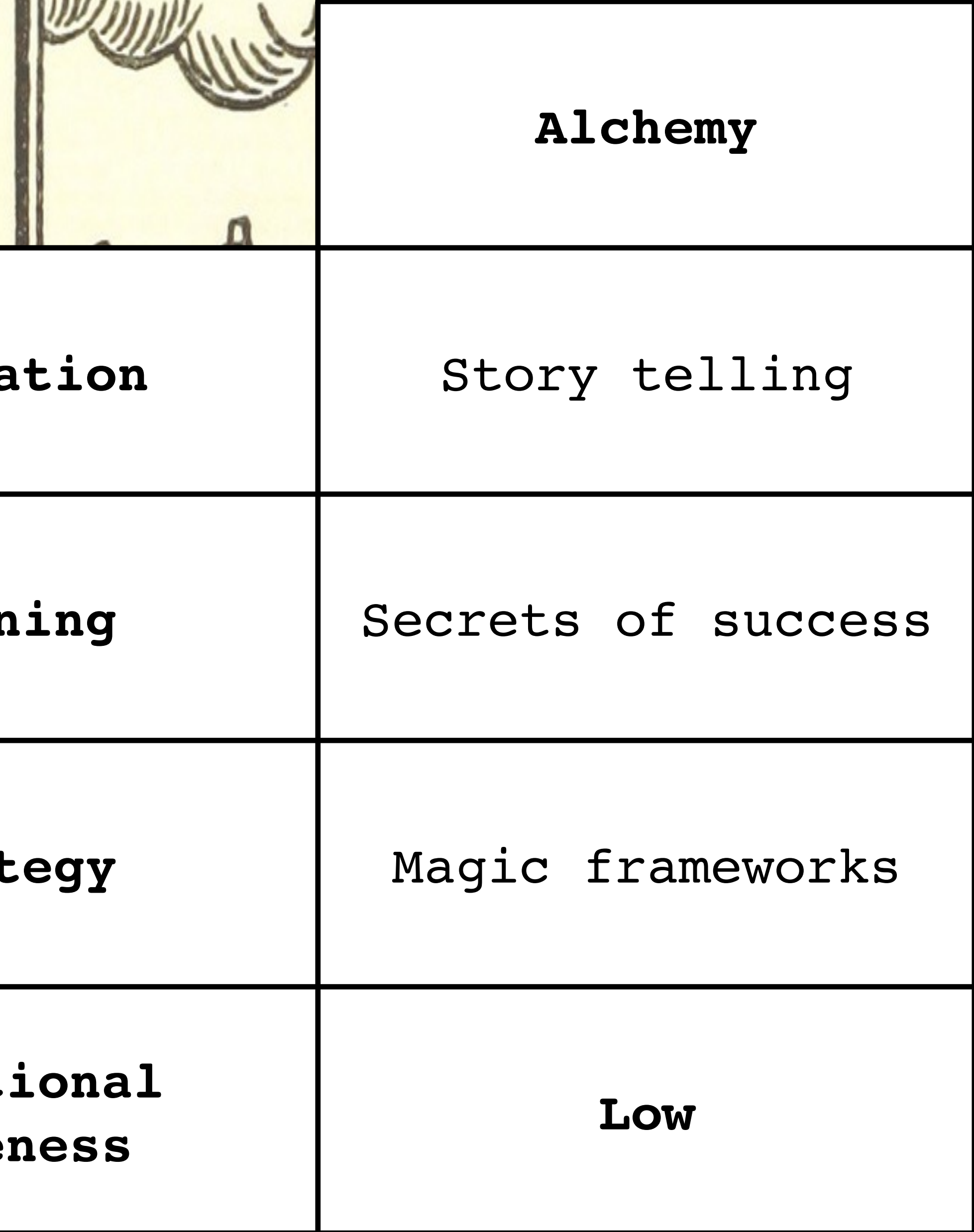

Chess		Alchemy
Visual	Navigation	Story telling
Context specific	Learning	Secrets of success
Position and movement	Strategy	Magic frameworks
High	Situational Awareness	Low

Why did you bomb
that hill?





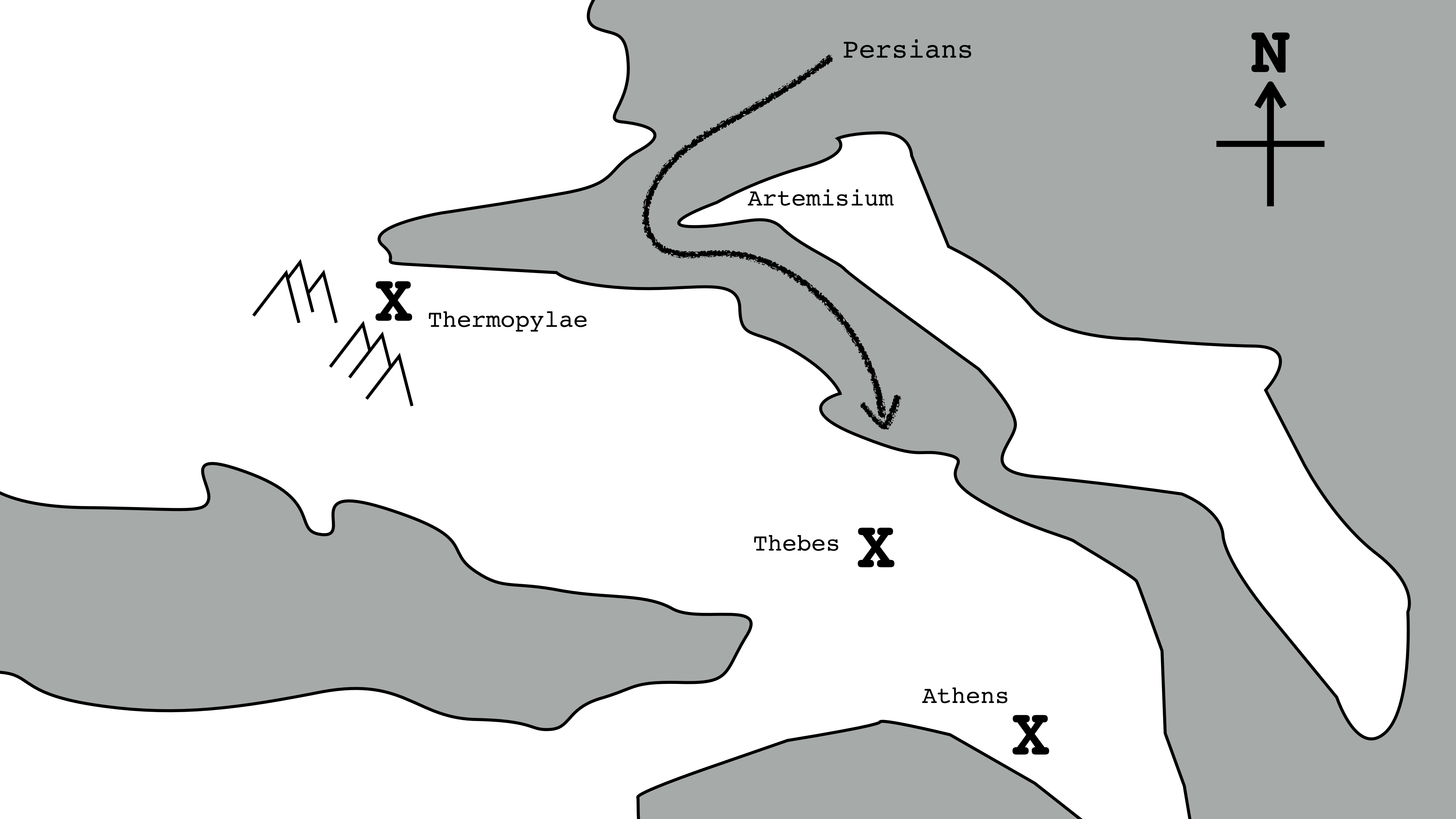

Persians

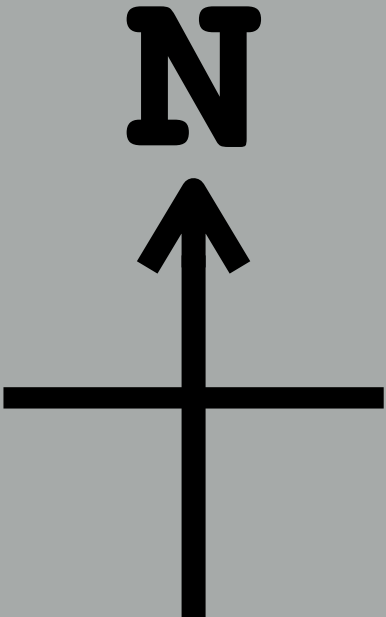

Artemisium



X

Thermopylae

X

Thebes

X

Athens

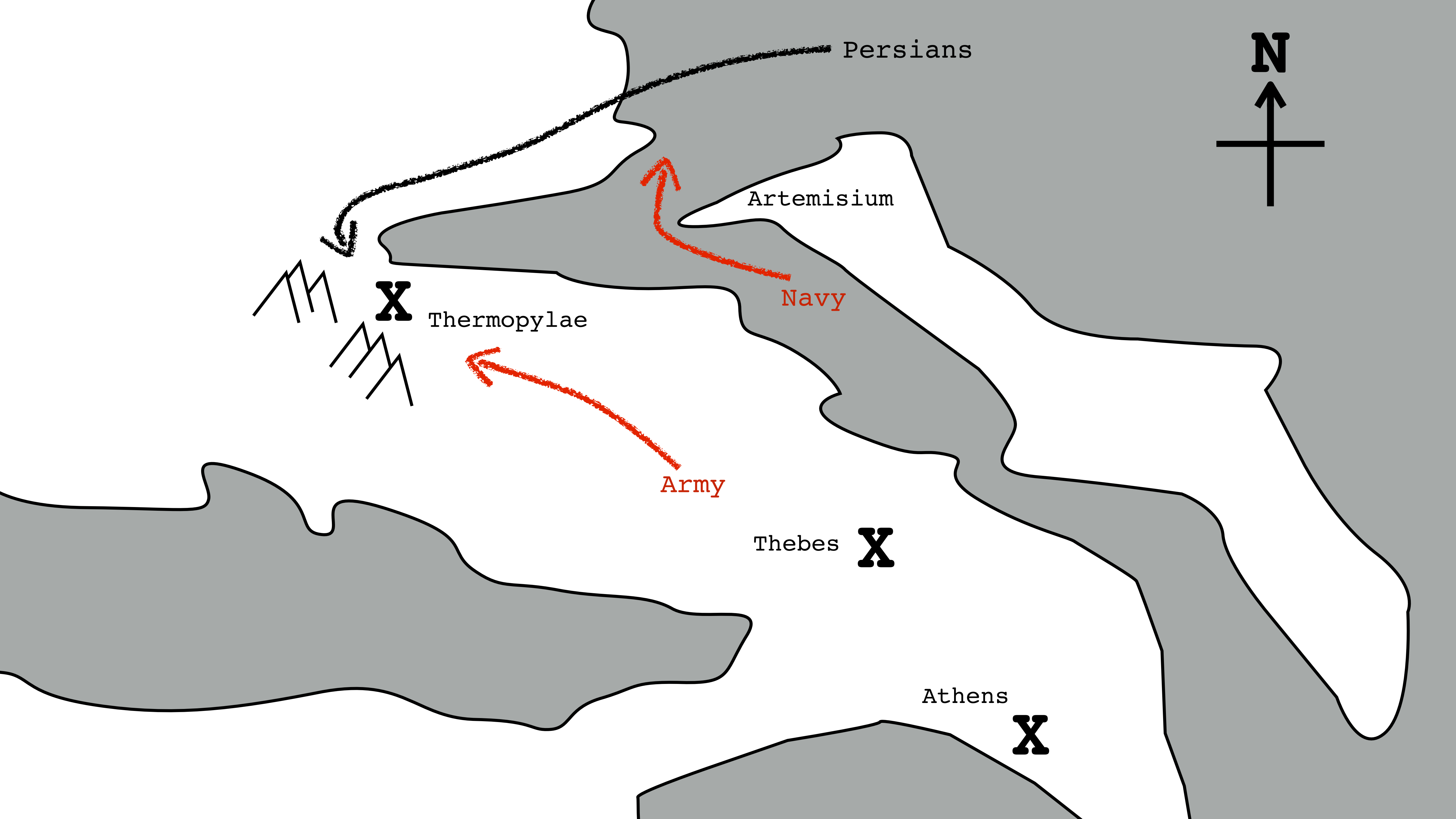

Persians

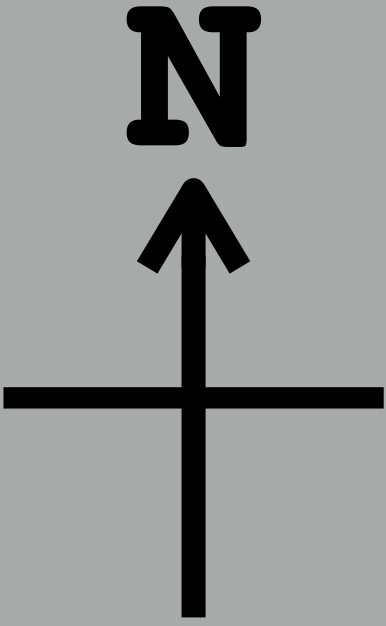

Artemisium

Navy

Thermopylae



Army

Thebes



Athens

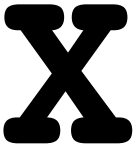

Strengths

A well trained Spartan army

A high level of motivation
not to become a Persian
slave

Weaknesses

The Ephors might stop the
Spartans turning up

A lot of Persians ARE
turning up

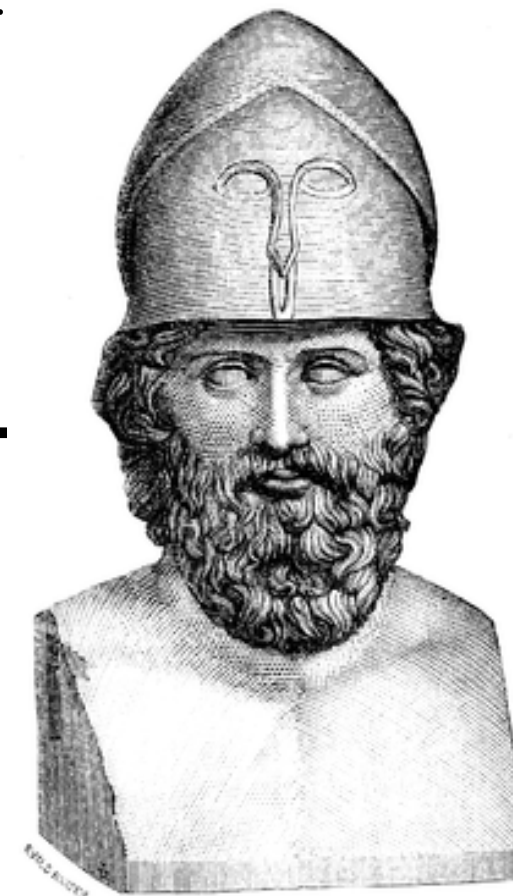

Opportunities

Get rid of the Persians

Get rid of the Spartans

Threats

Persians get rid of us

The Oracle says a really
dodgy film might be
produced over 2,000
years later

What would you use to communicate and determine strategy in battle?

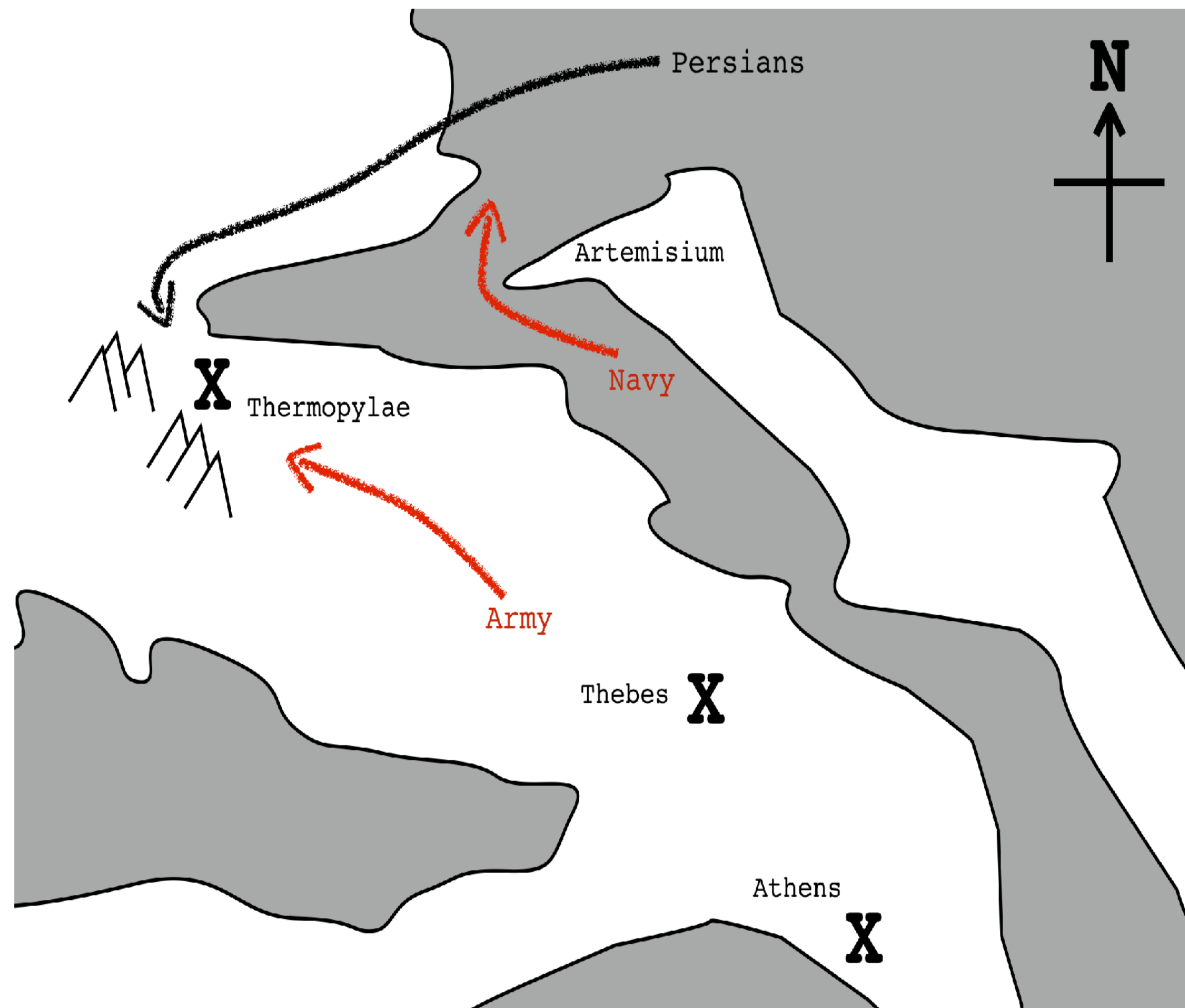

position and movement

Strengths A well trained Spartan army A high level of motivation not to become a Persian slave	Weaknesses The Ephors might stop the Spartans turning up A lot of Persians ARE turning up
Opportunities Get rid of the Persians Get rid of the Spartans	Threats Persians get rid of us The Oracle says a really dodgy film might be produced over 2,000 years later



magic framework

Chess		Alchemy
Visual	Navigation	Story telling
Context specific	Learning	Secrets of success
Position and movement	Strategy	Magic frameworks
High	Situational Awareness	Low



**FAKE
CEO**

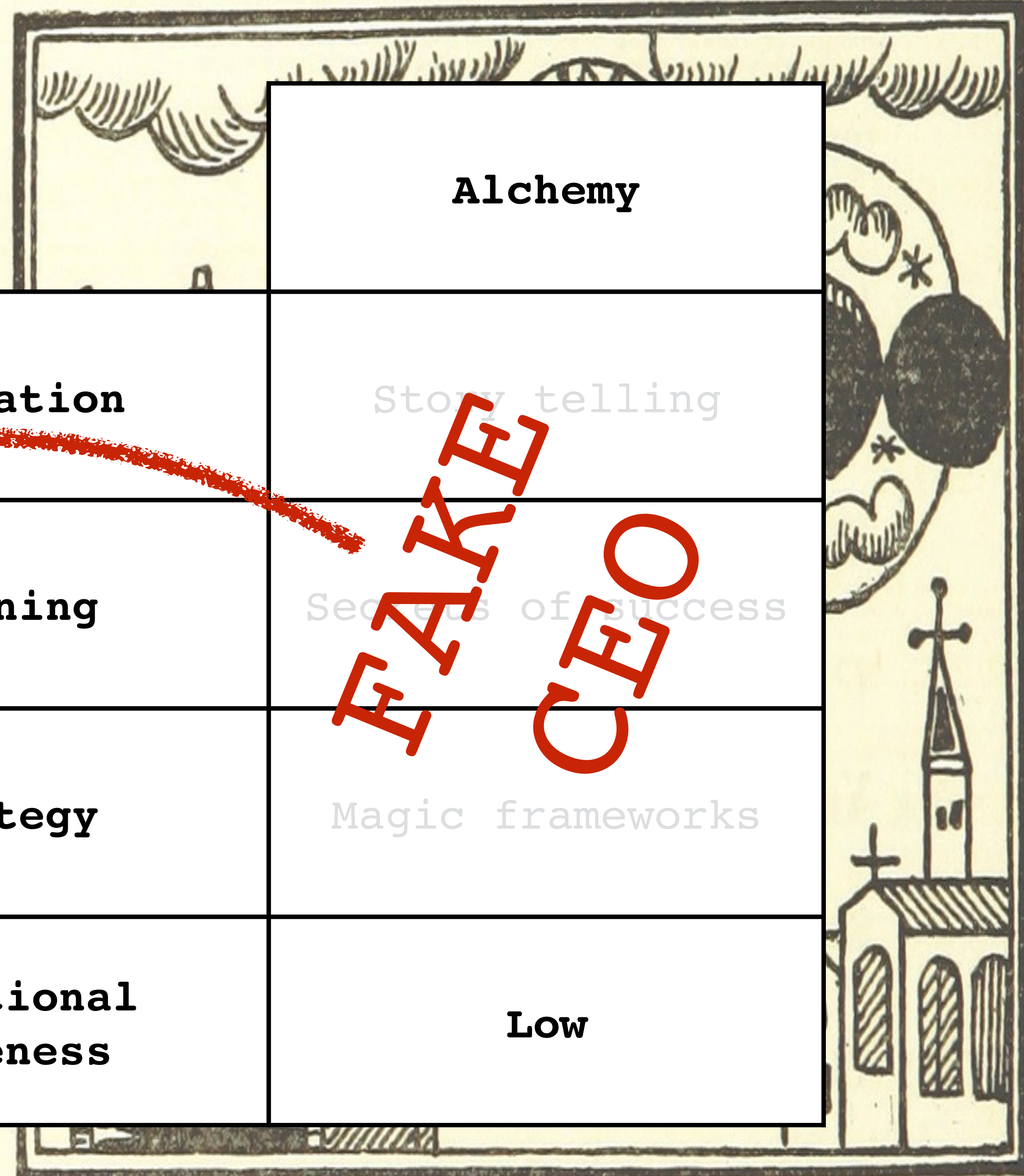

Strategy



Maps

Communication



Patterns

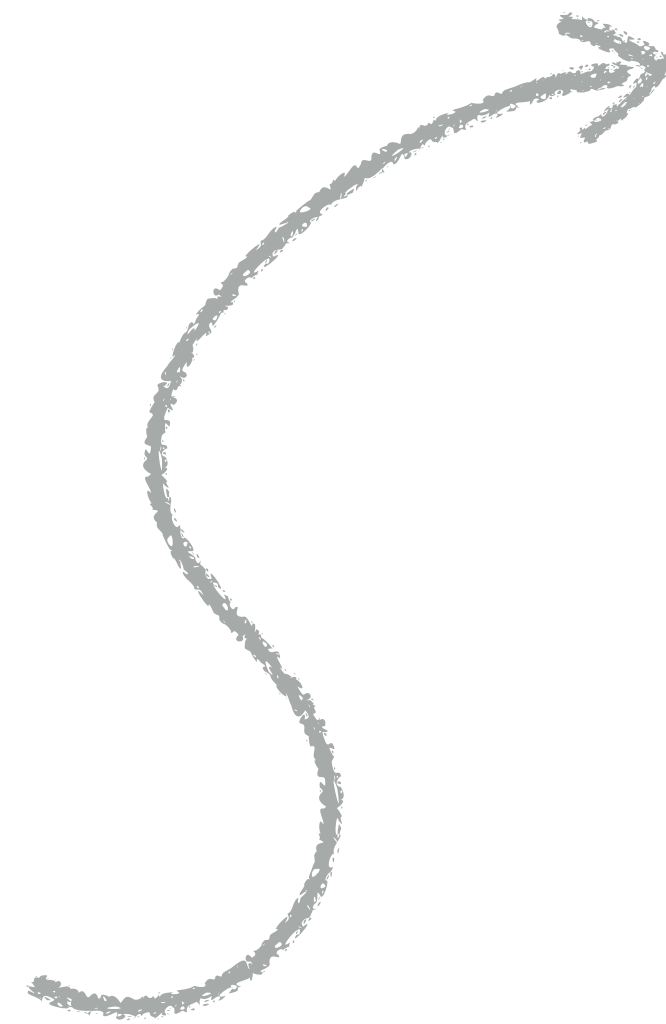

Anticipation



Organisation



Leadership

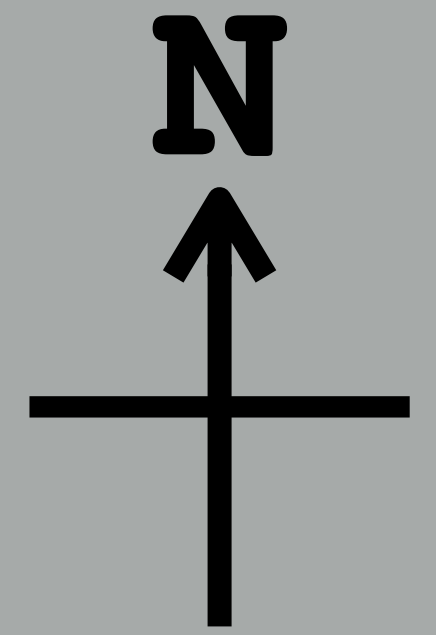

SERVERLESS

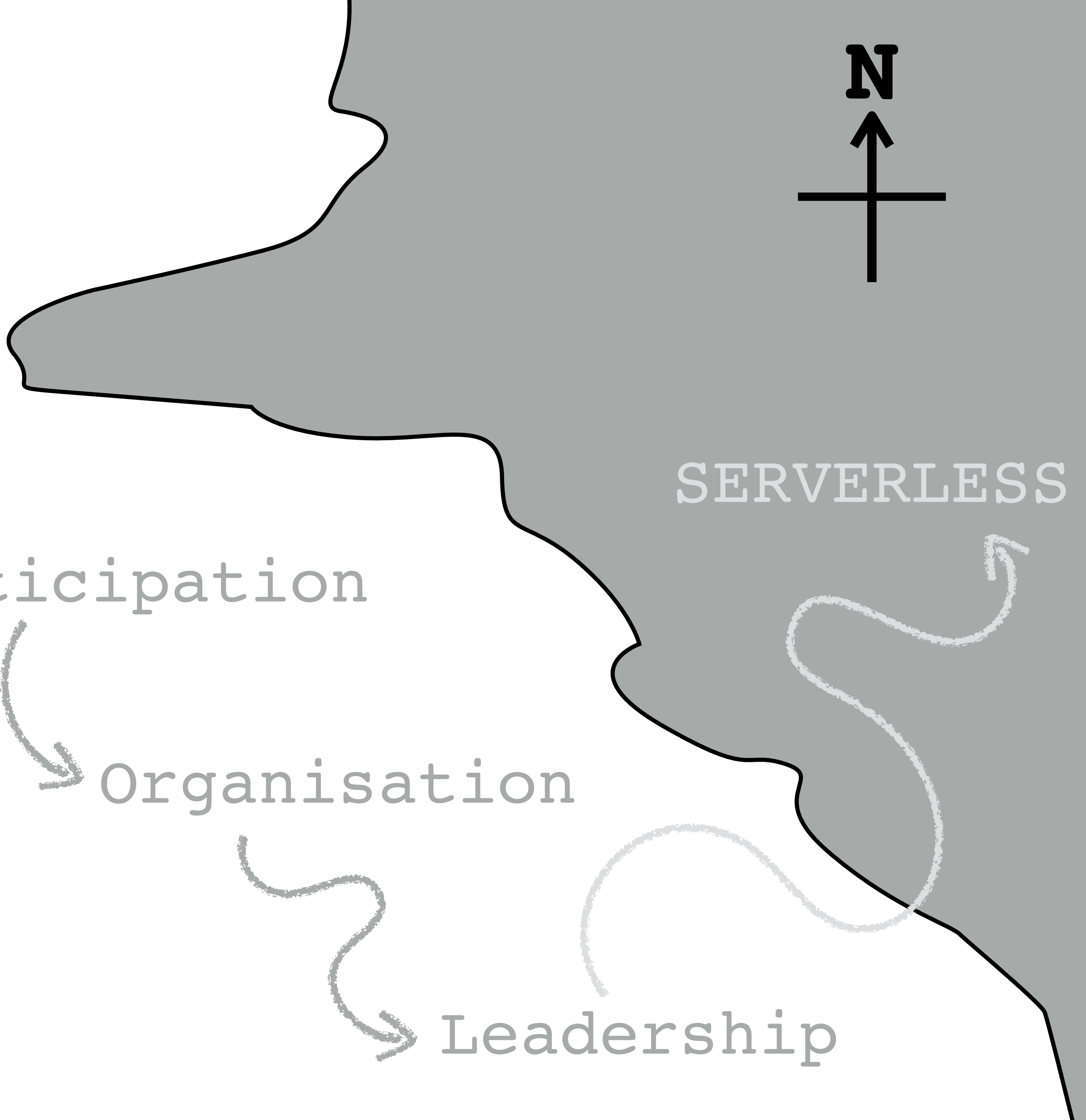
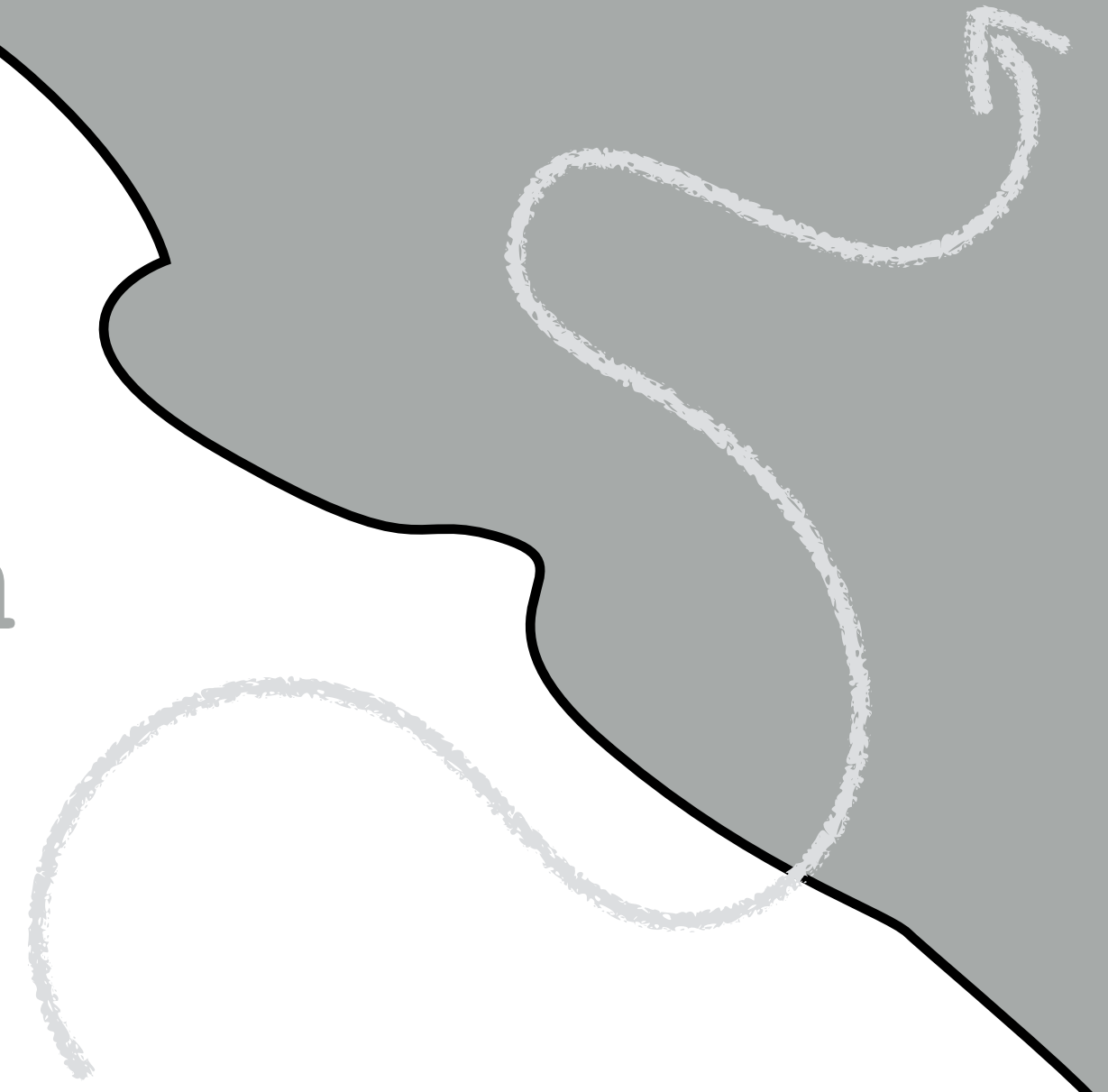

WHY DO MAPS
MATTER?



Julian Mason, APR 2011, CC by 2.0

<https://www.flickr.com/photos/meandmyshadow/5687986018/>

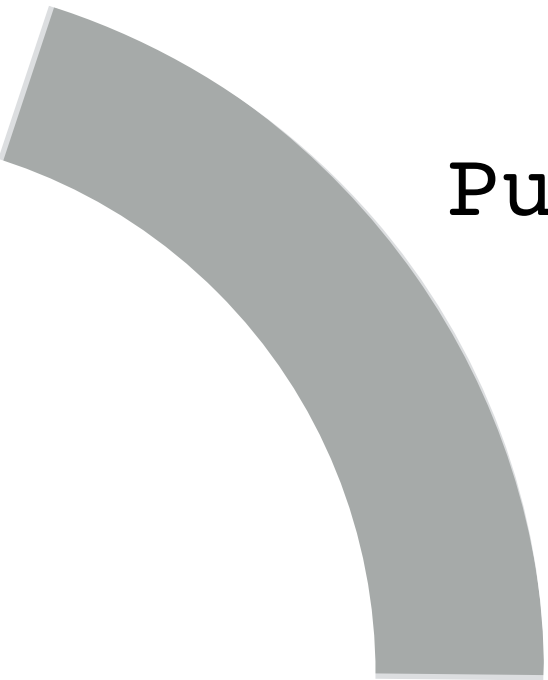

Purpose

The Strategy Cycle
Sun Tzu's five factors



The Strategy Cycle
Sun Tzu's five factors

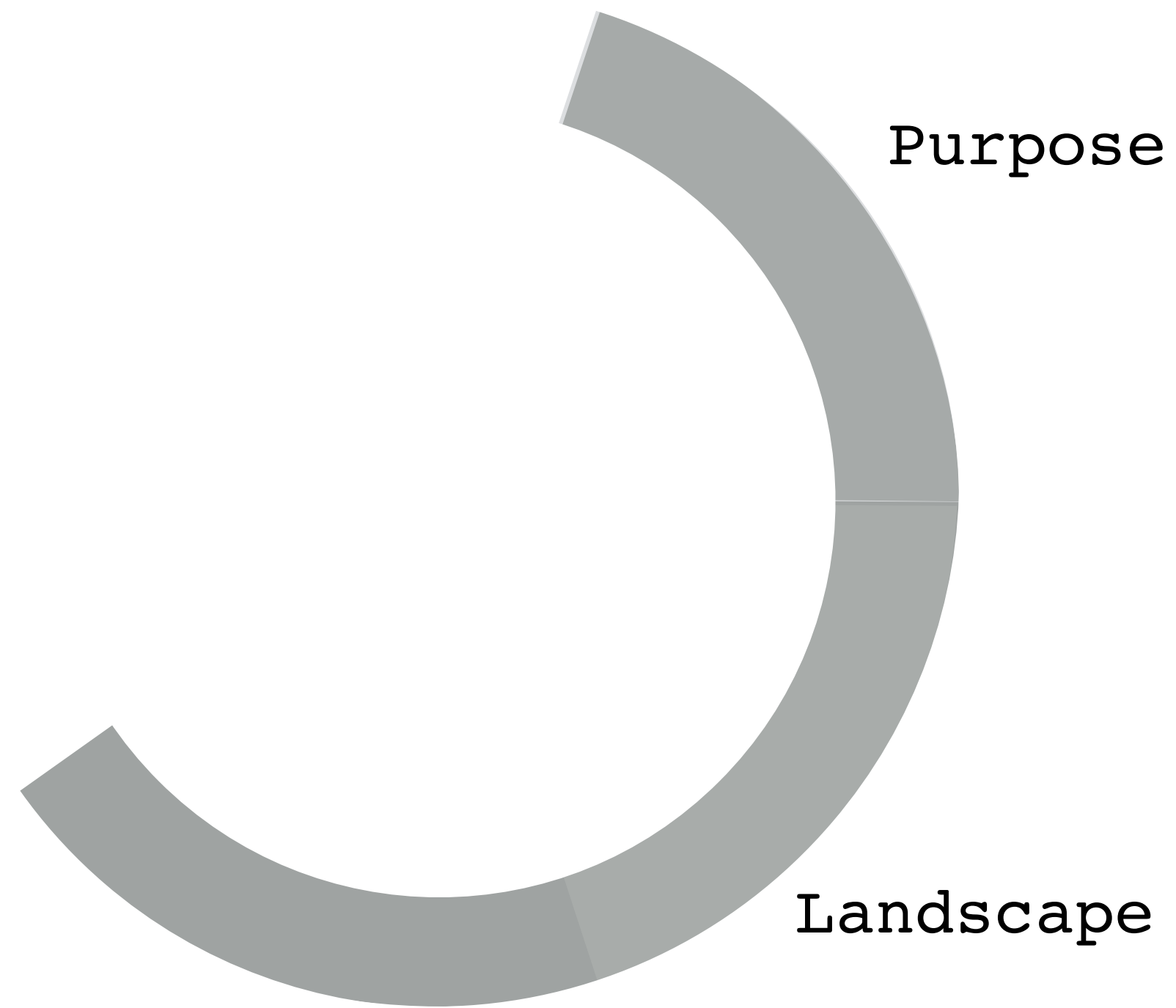

Purpose

Landscape

Climate

The Strategy Cycle

Sun Tzu's five factors

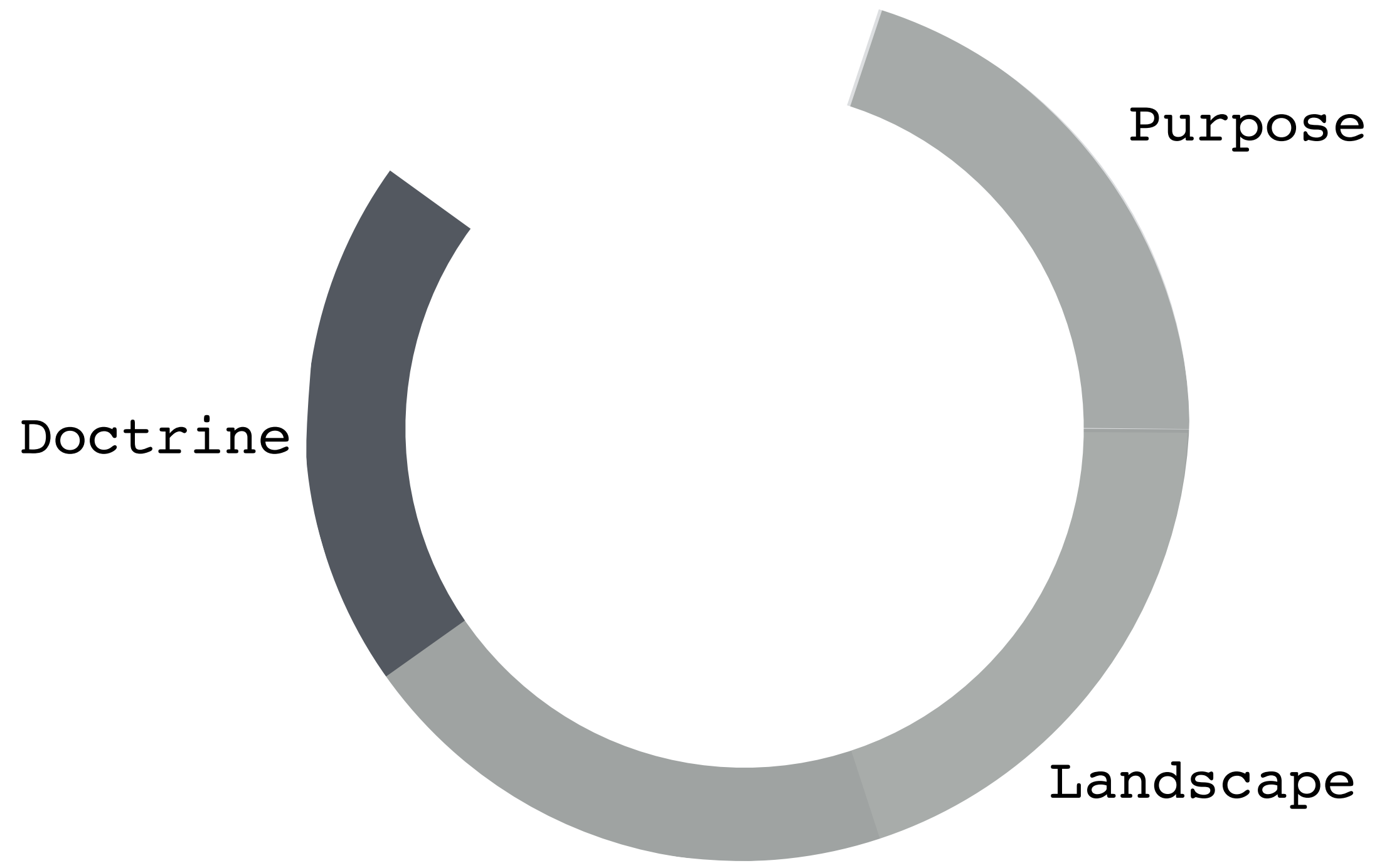

The Strategy Cycle
Sun Tzu's five factors

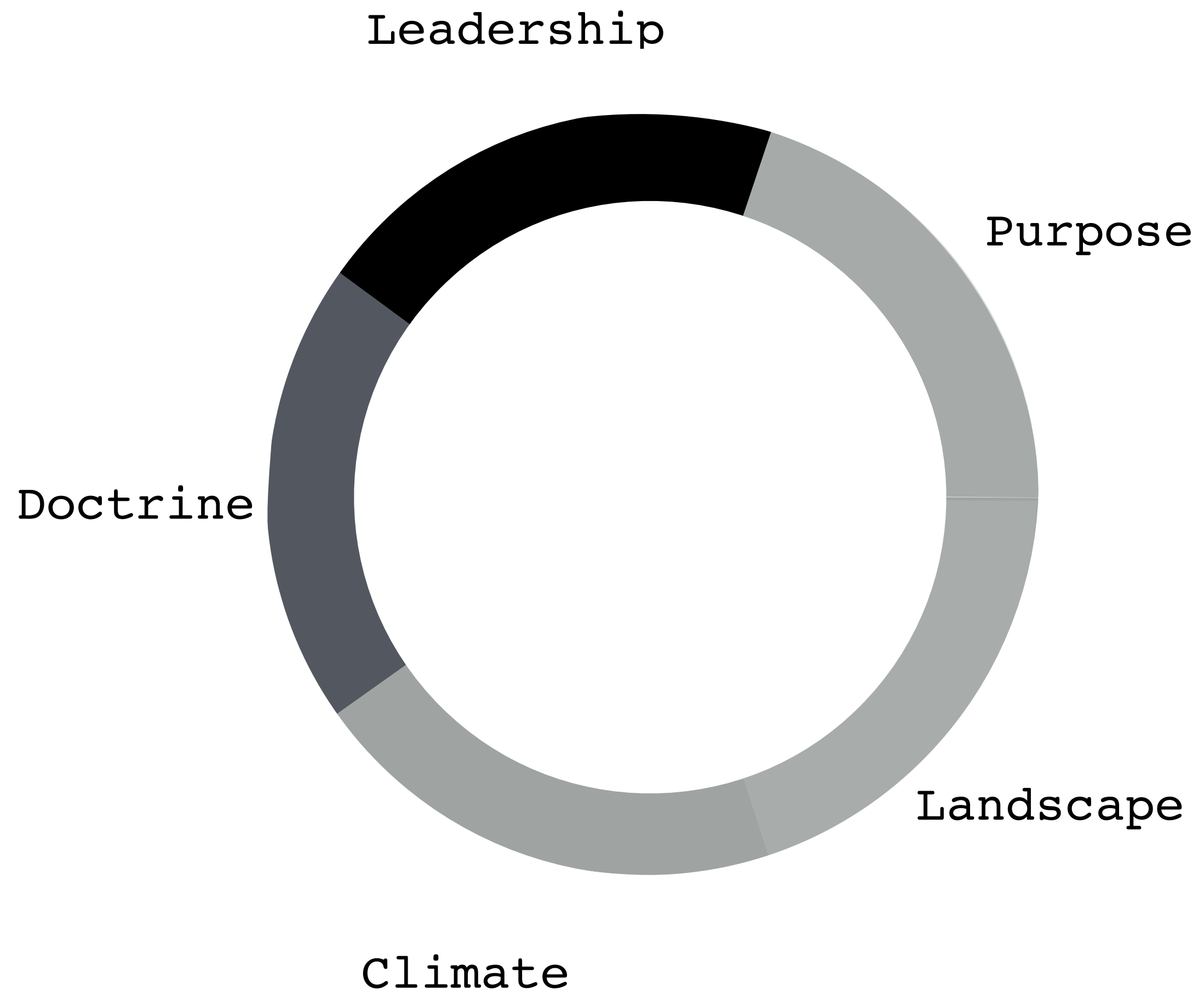

The Strategy Cycle
Sun Tzu's five factors

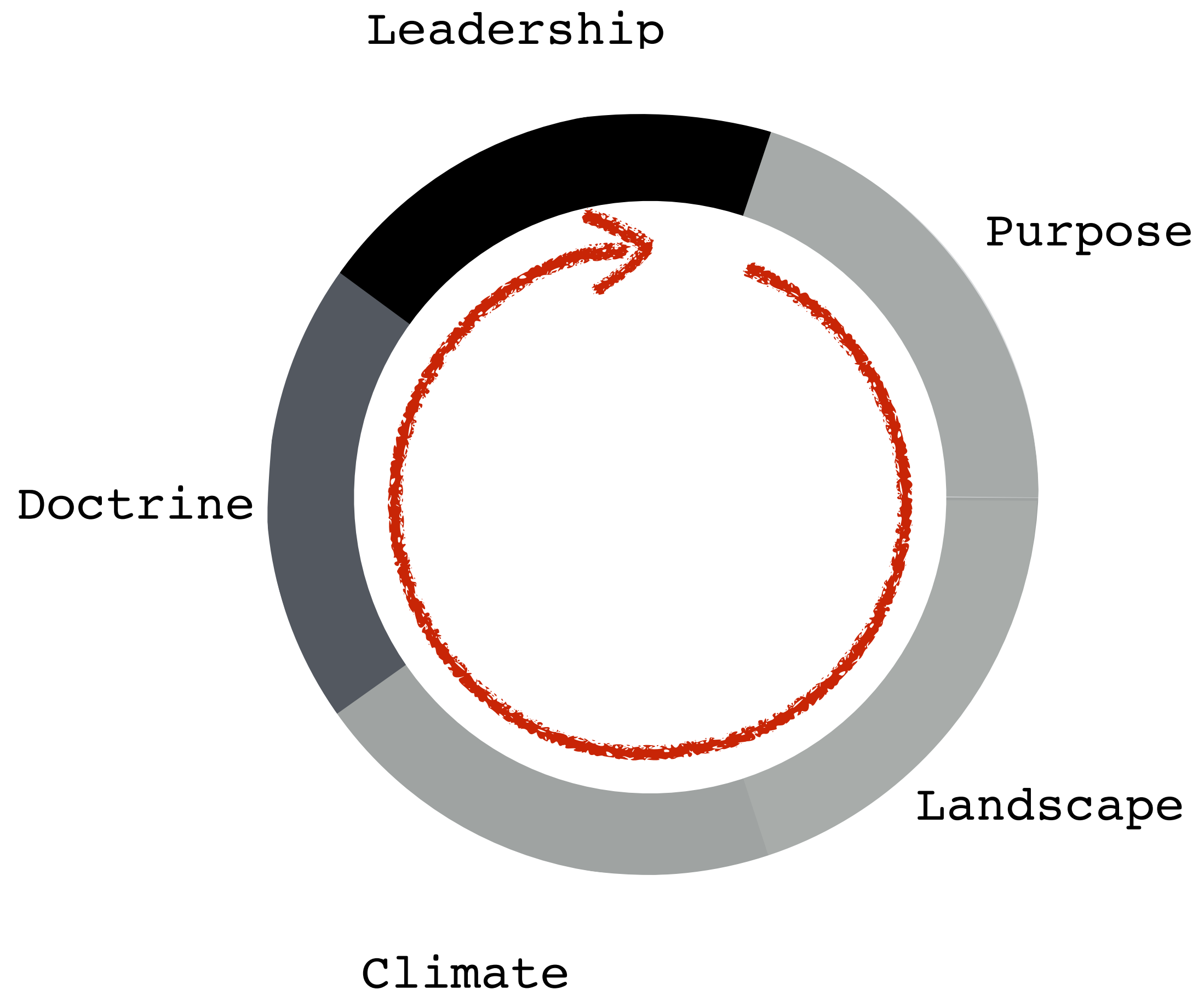

The Strategy Cycle
Sun Tzu's five factors

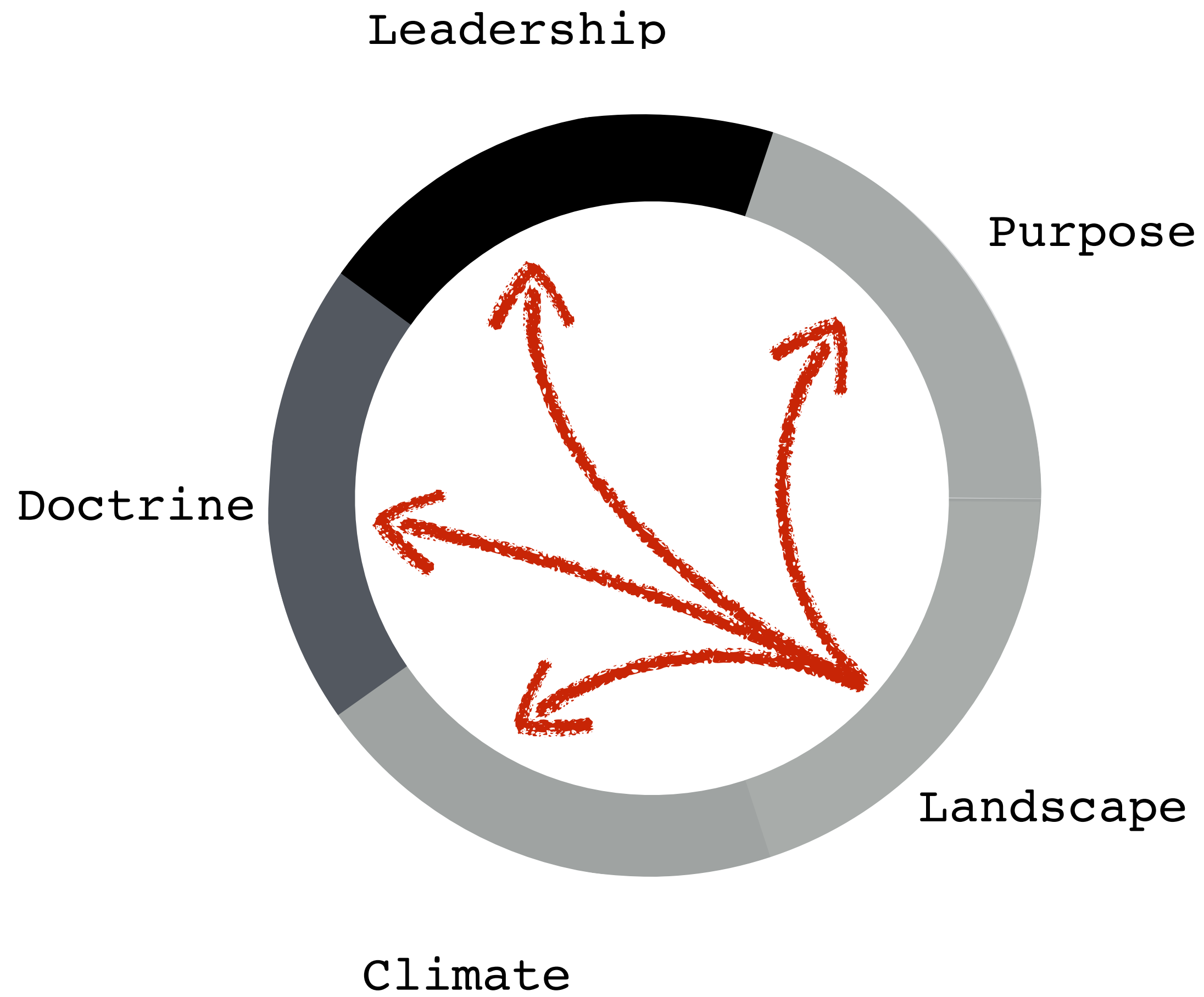

The Strategy Cycle
Sun Tzu's five factors



John Boyd, USAF

Public Domain, US Gov, 2012

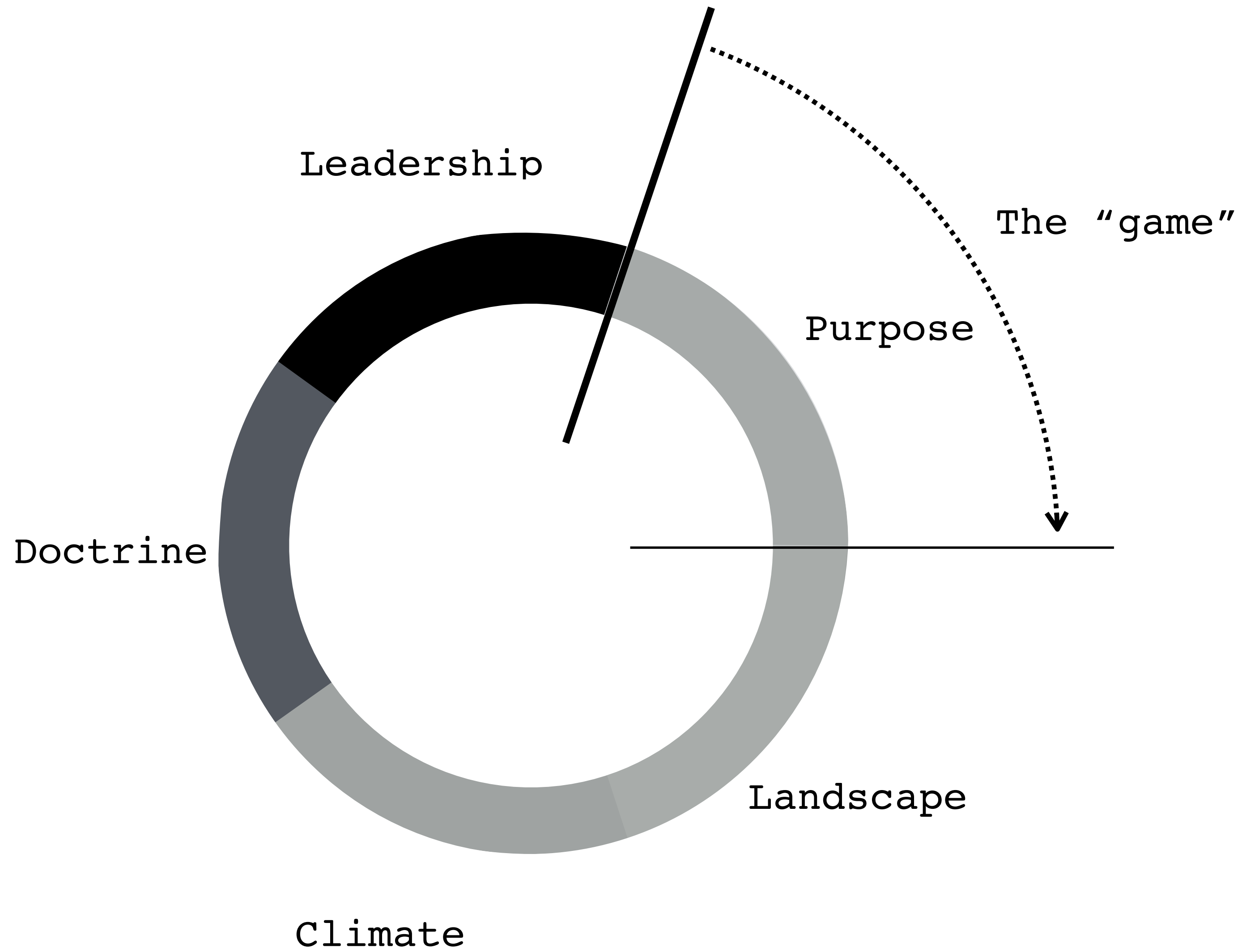

The Strategy Cycle
Sun Tzu's five factors
John Boyd's OODA loop

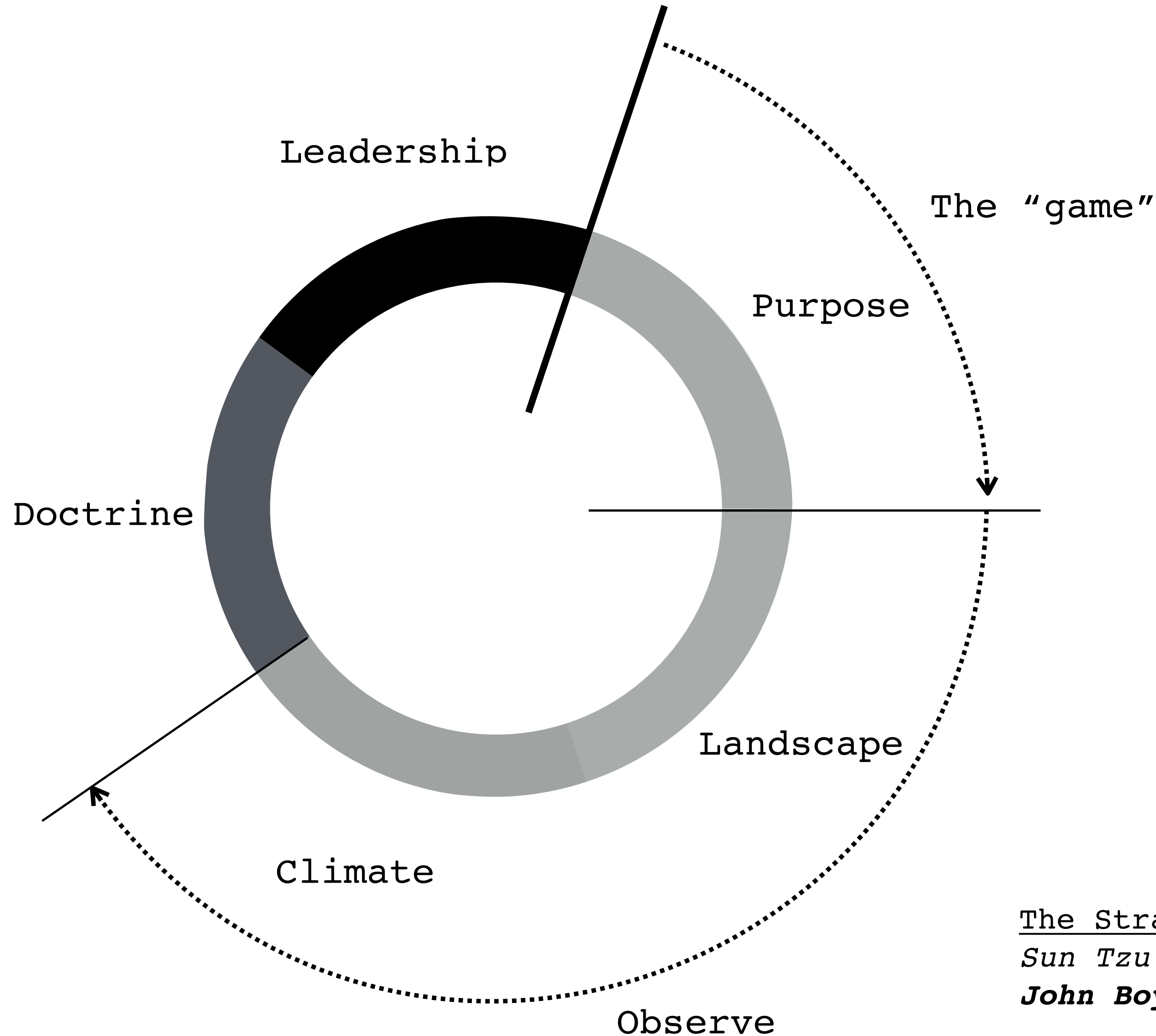

The Strategy Cycle
Sun Tzu's five factors
John Boyd's OODA loop

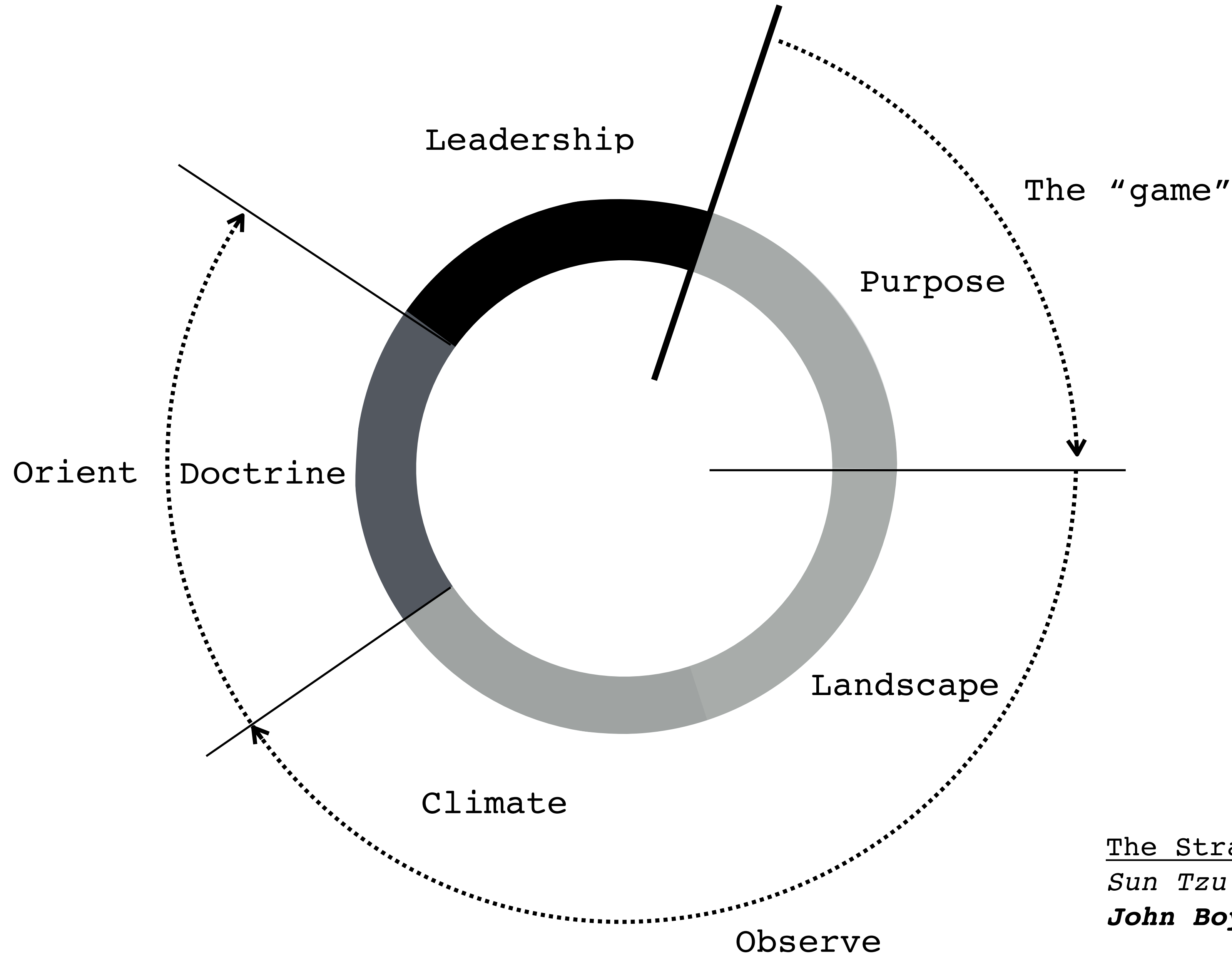

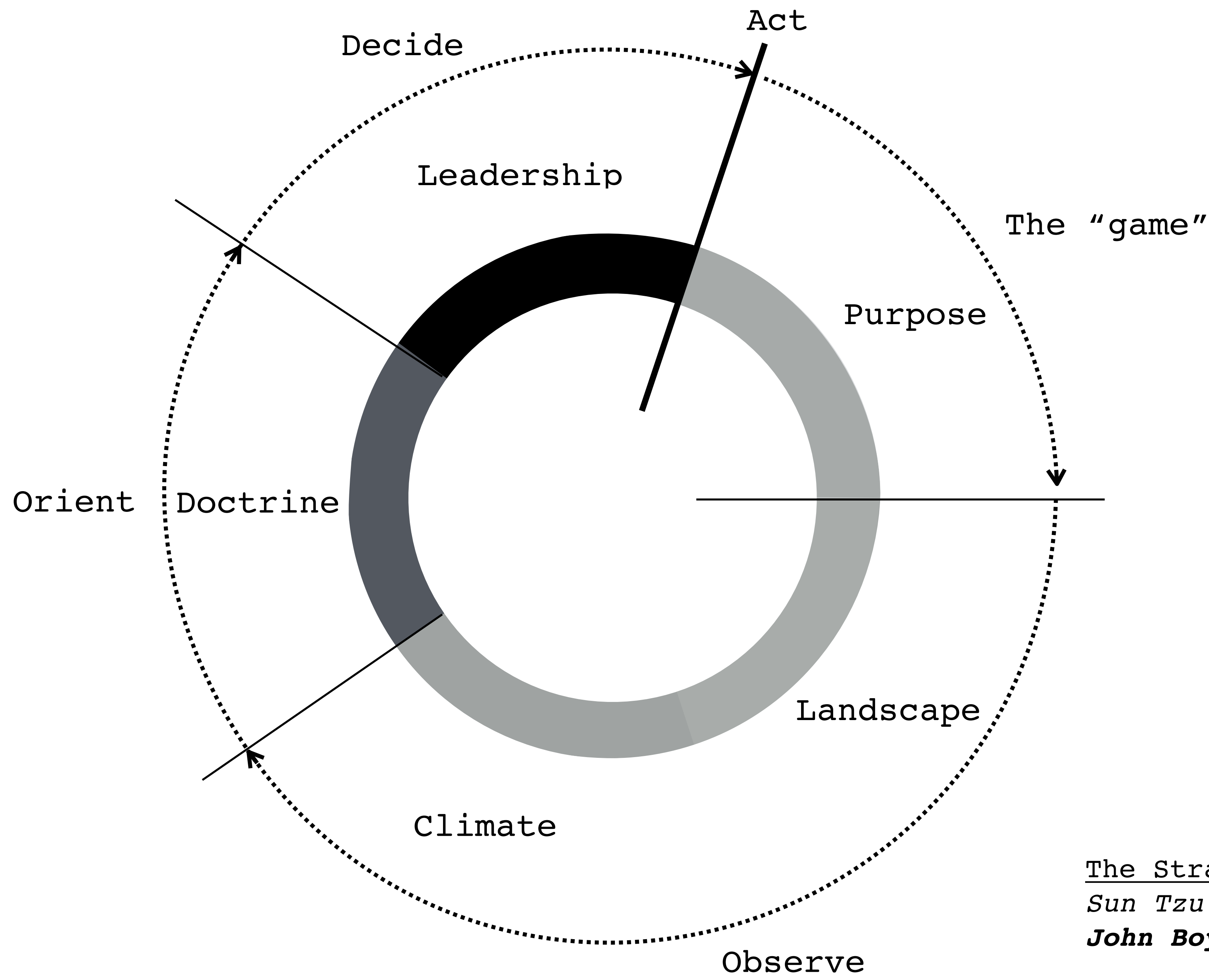

The Strategy Cycle
Sun Tzu's five factors
John Boyd's OODA loop

IMPORTANCE OF
WHY!

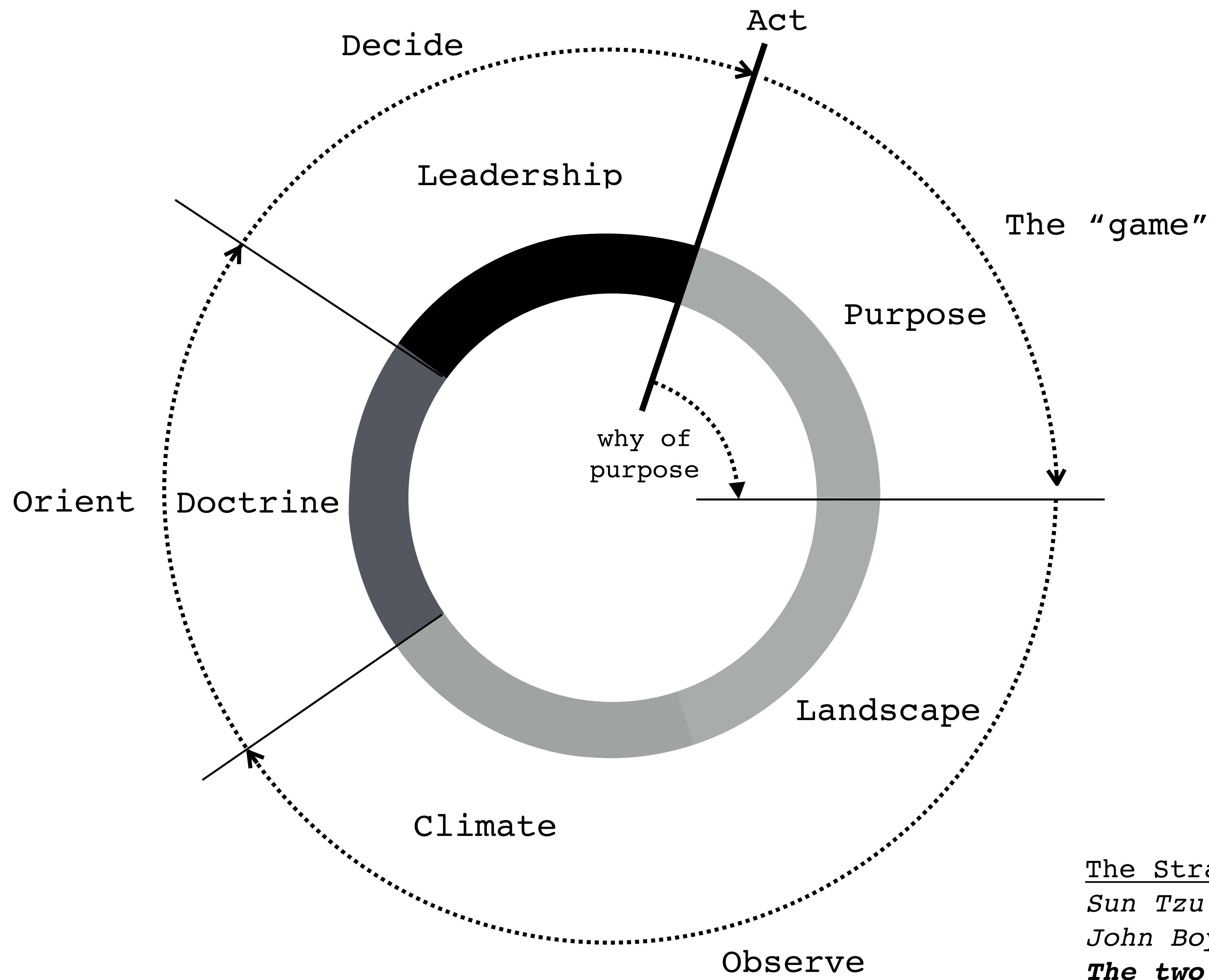

The Strategy Cycle
Sun Tzu's five factors
John Boyd's OODA loop
The two types of why

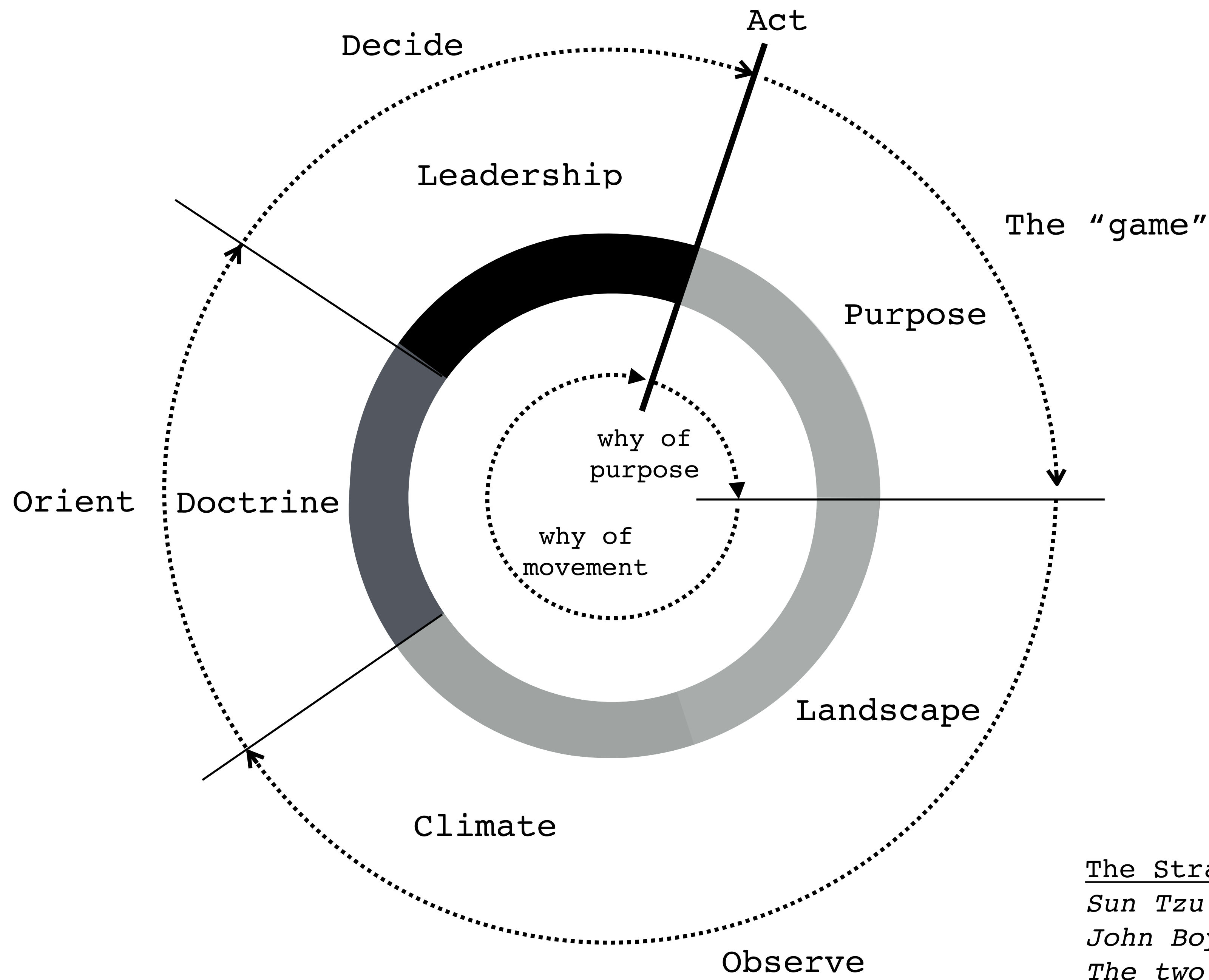

The Strategy Cycle
Sun Tzu's five factors
John Boyd's OODA loop
The two types of why

Why of purpose = To Win!

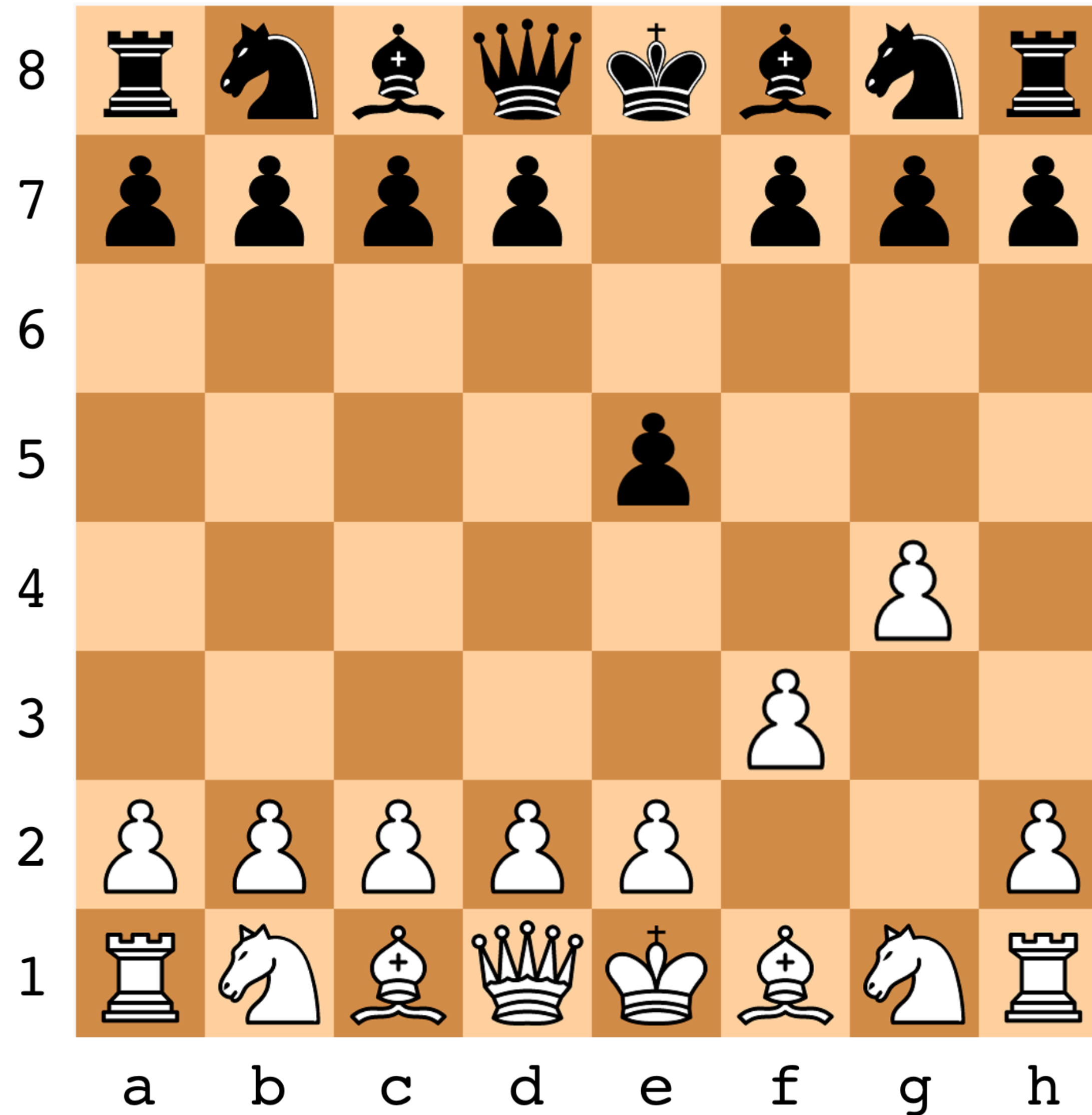

Why of movement = here or there?

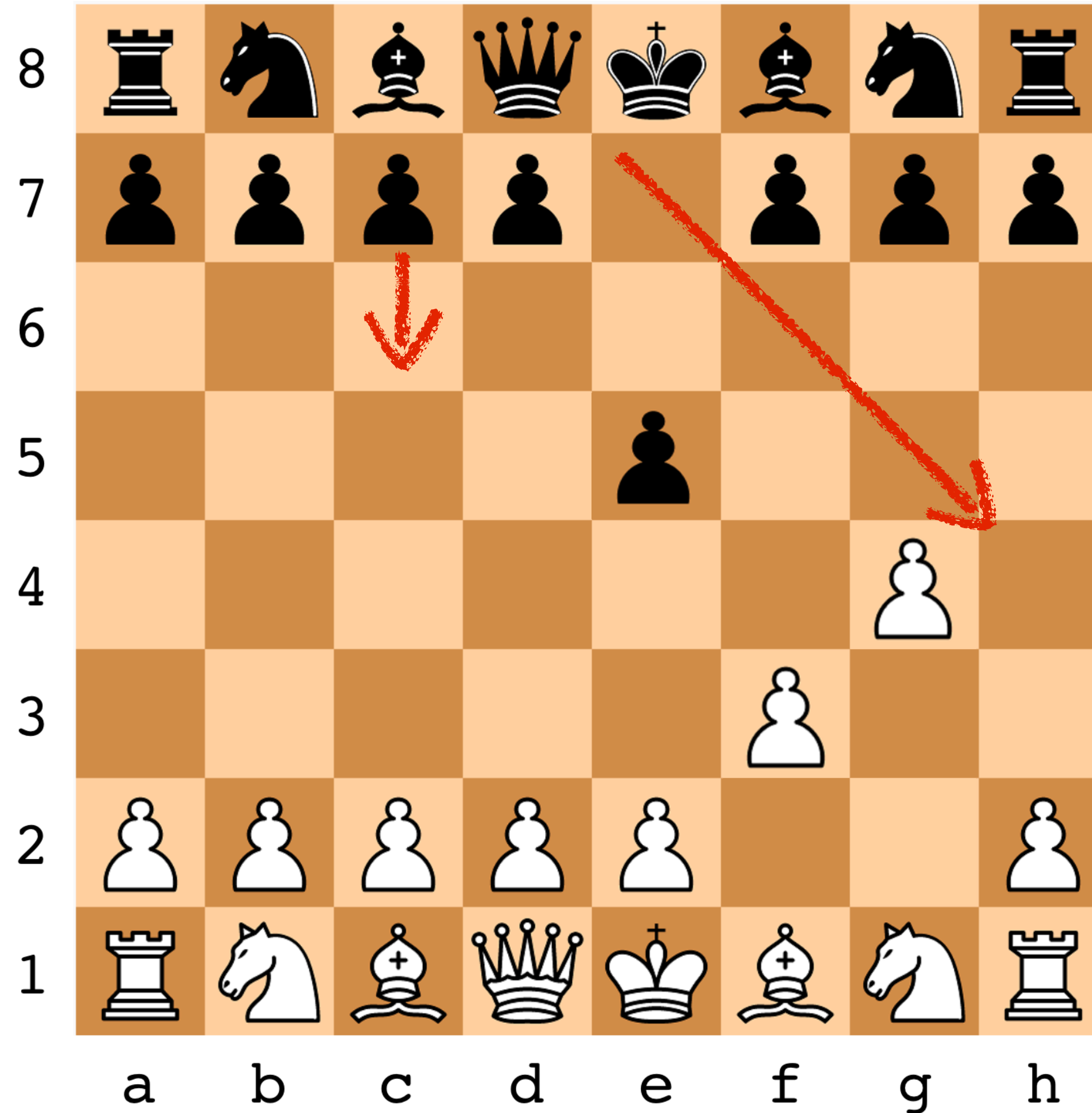

Movement = LEARNING

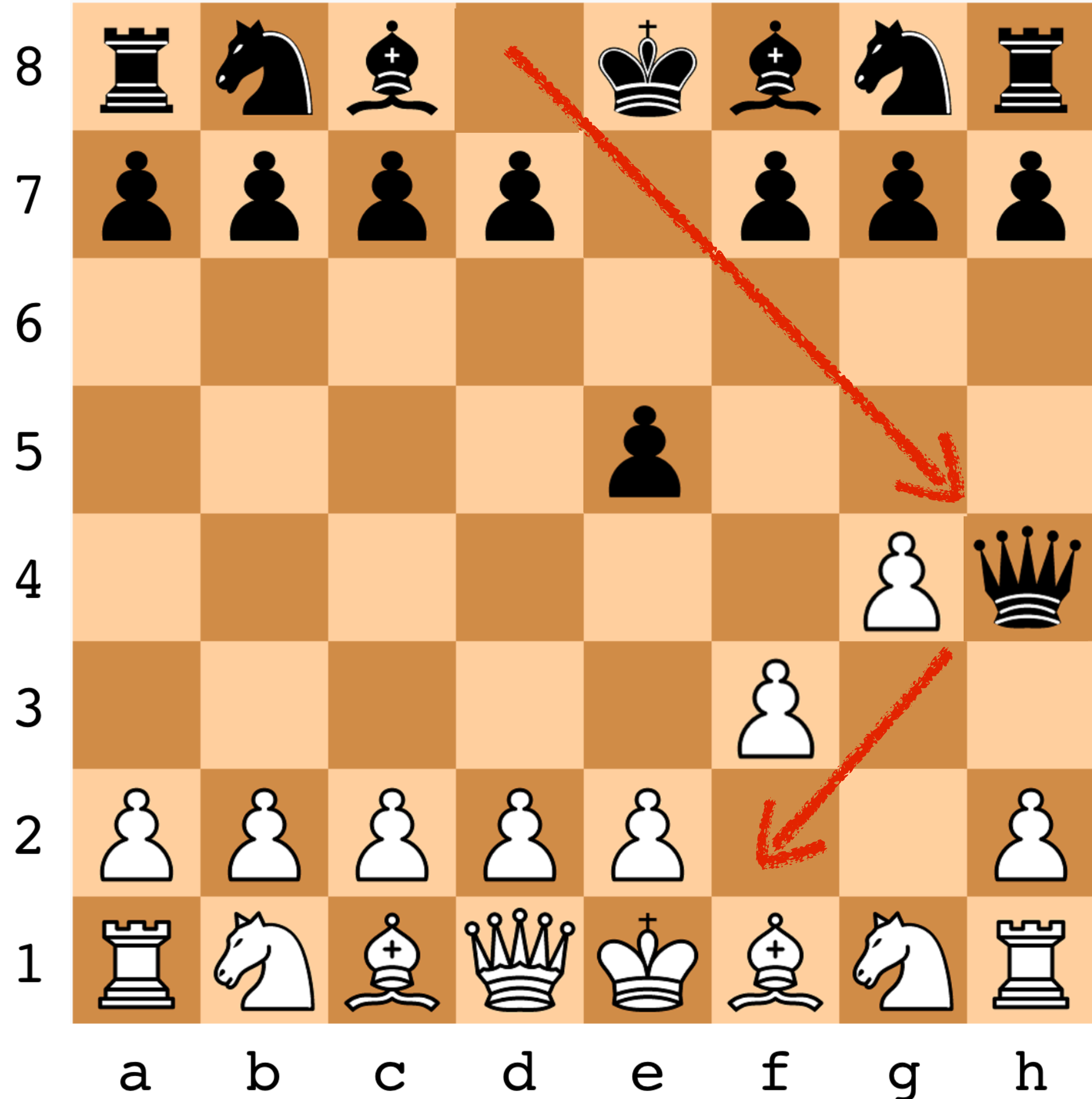

Checkmate

Movement = LEARNING

Perceive

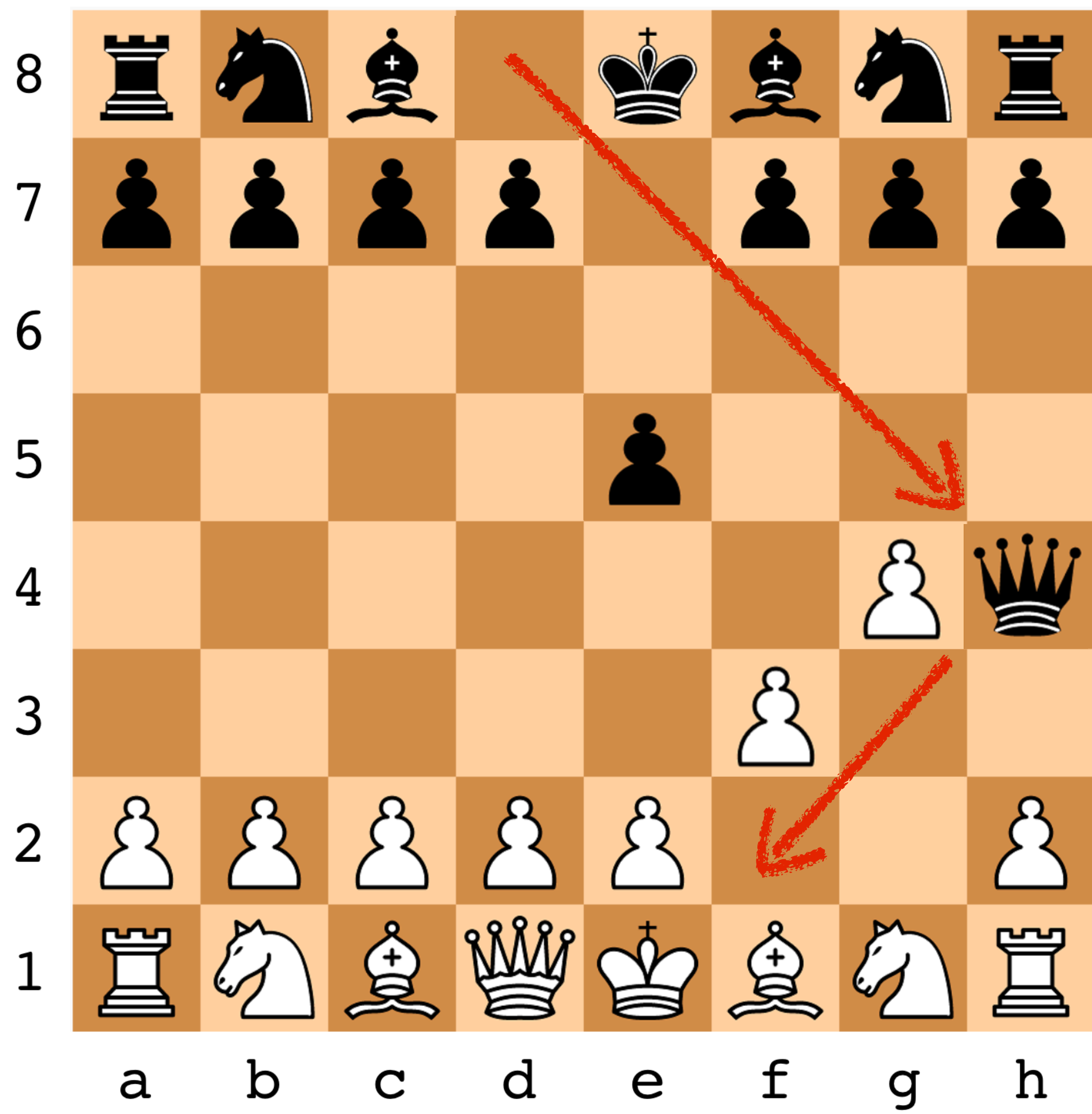

Checkmate



Top quality prints and a **FREE** online photo service

- **Digital and film**
Easy upload for digital pictures and film rolls
- **Create online albums** **FREE**
Unlimited secure space for your pictures
- **Photo upload software** **FREE**
Upload your images from your desktop
- **Share your photos** **FREE**
Friends, family, workmates, share the moment
- **Buy prints and gifts**
Turn your favourite photos into great gifts

[Login](#)[forgotten password?](#)[Take the Tour](#)[Create an account](#)

Gifts Gallery

Turn your photos into great gifts!



Promotions

Share pictures & when friend registers, you both get 3 free 6x4 prints.



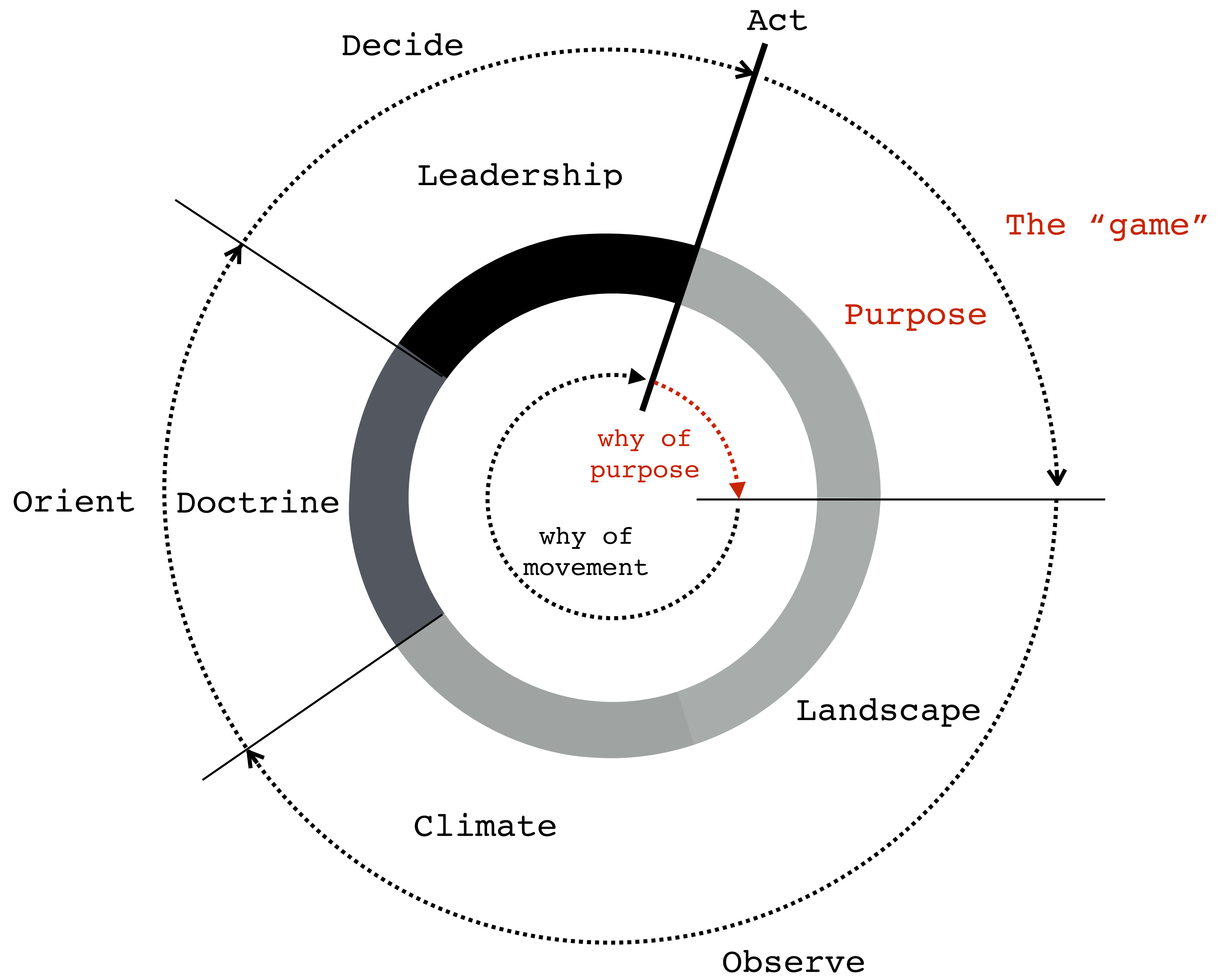

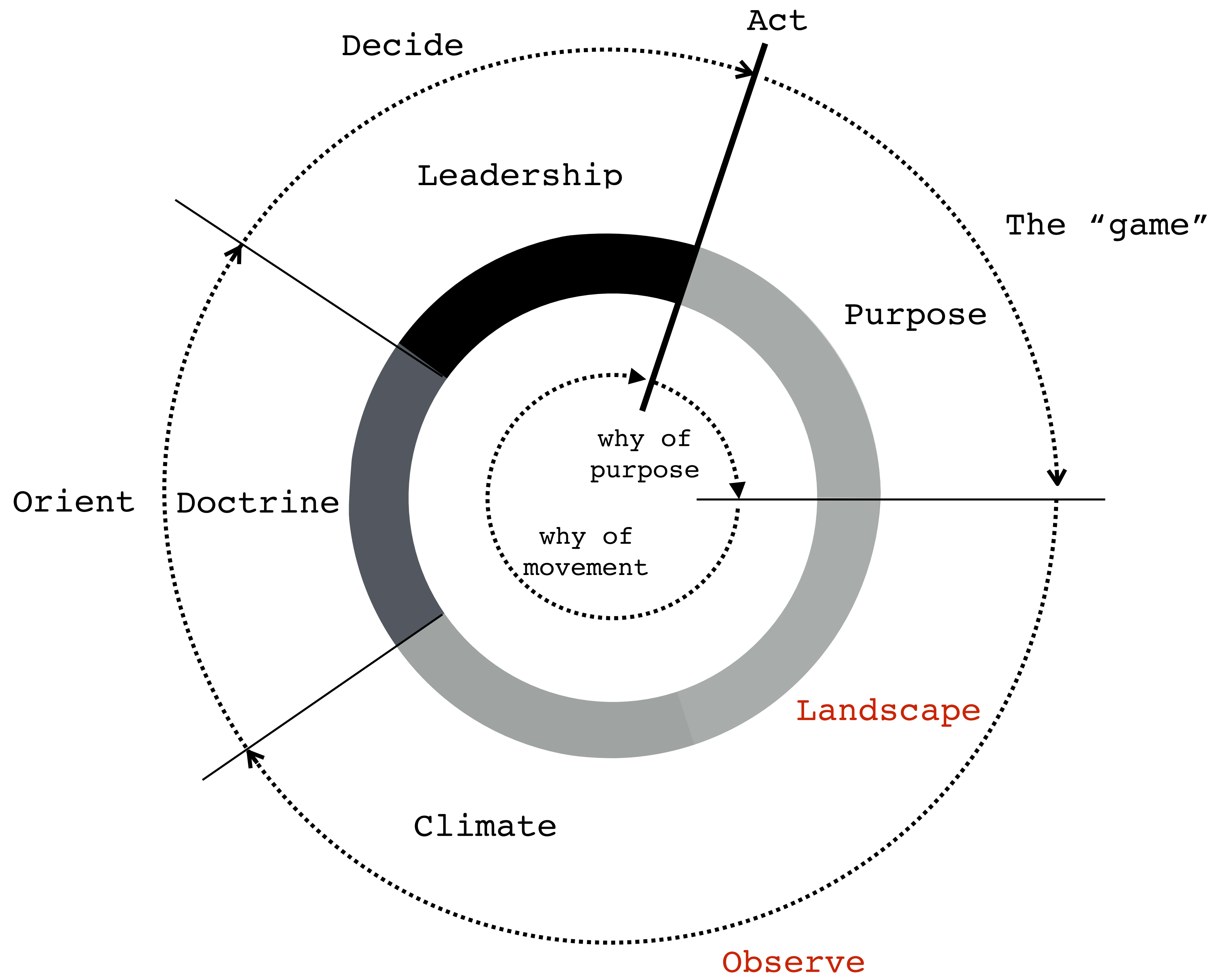

Systems Map

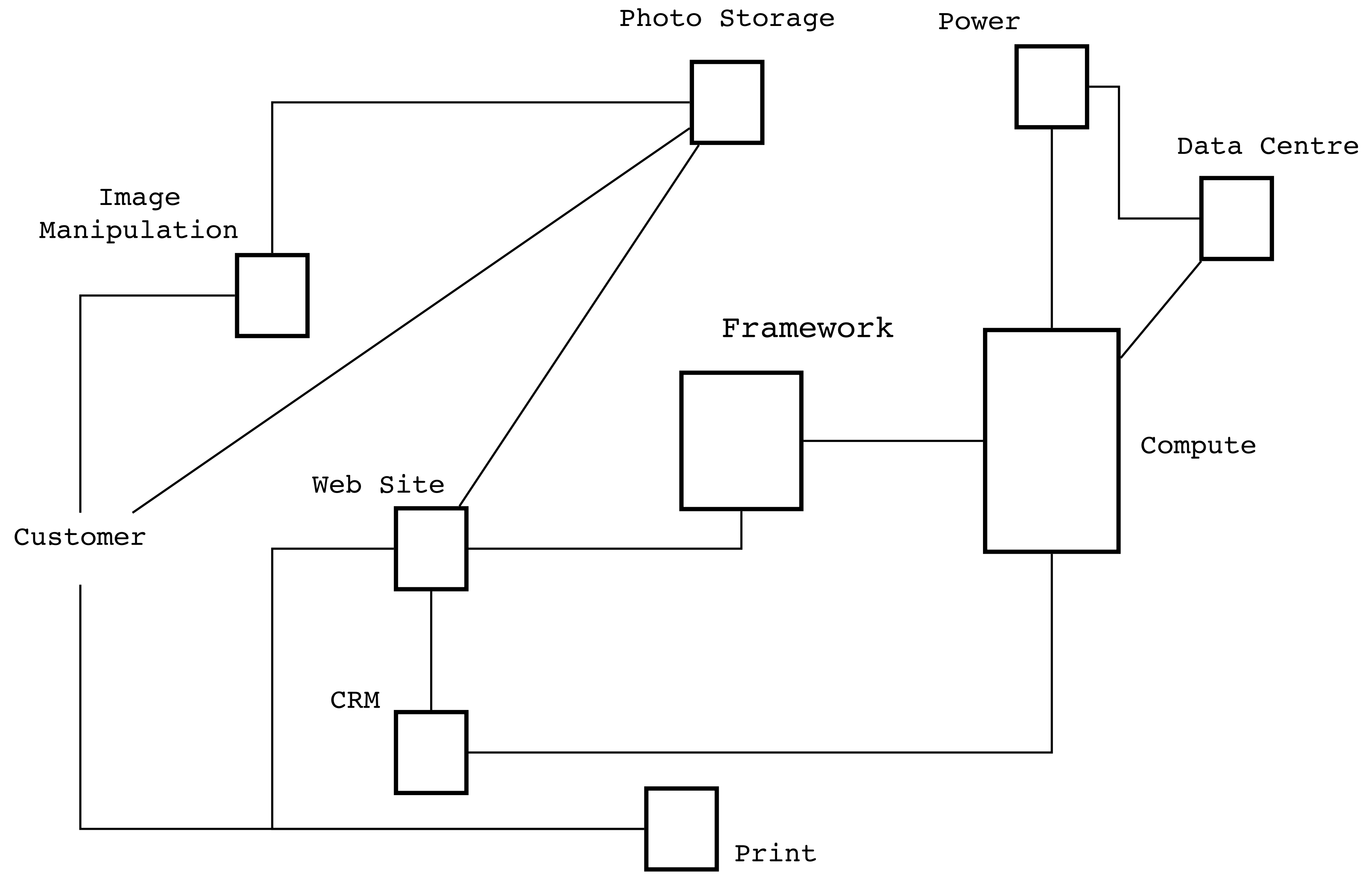

WHAT IS A MAP?

**3 GRAPHS
ARE THE
SAME**

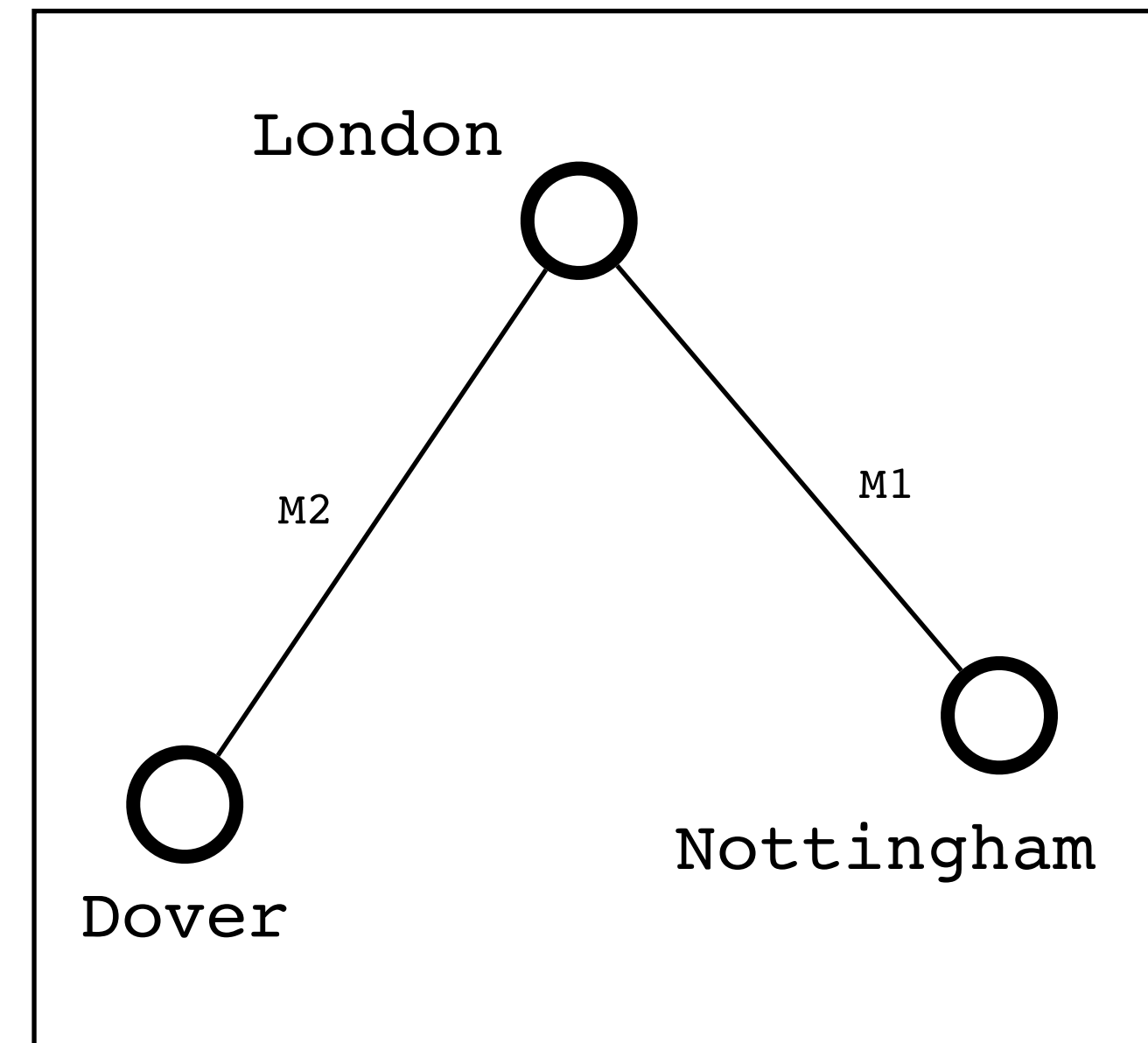
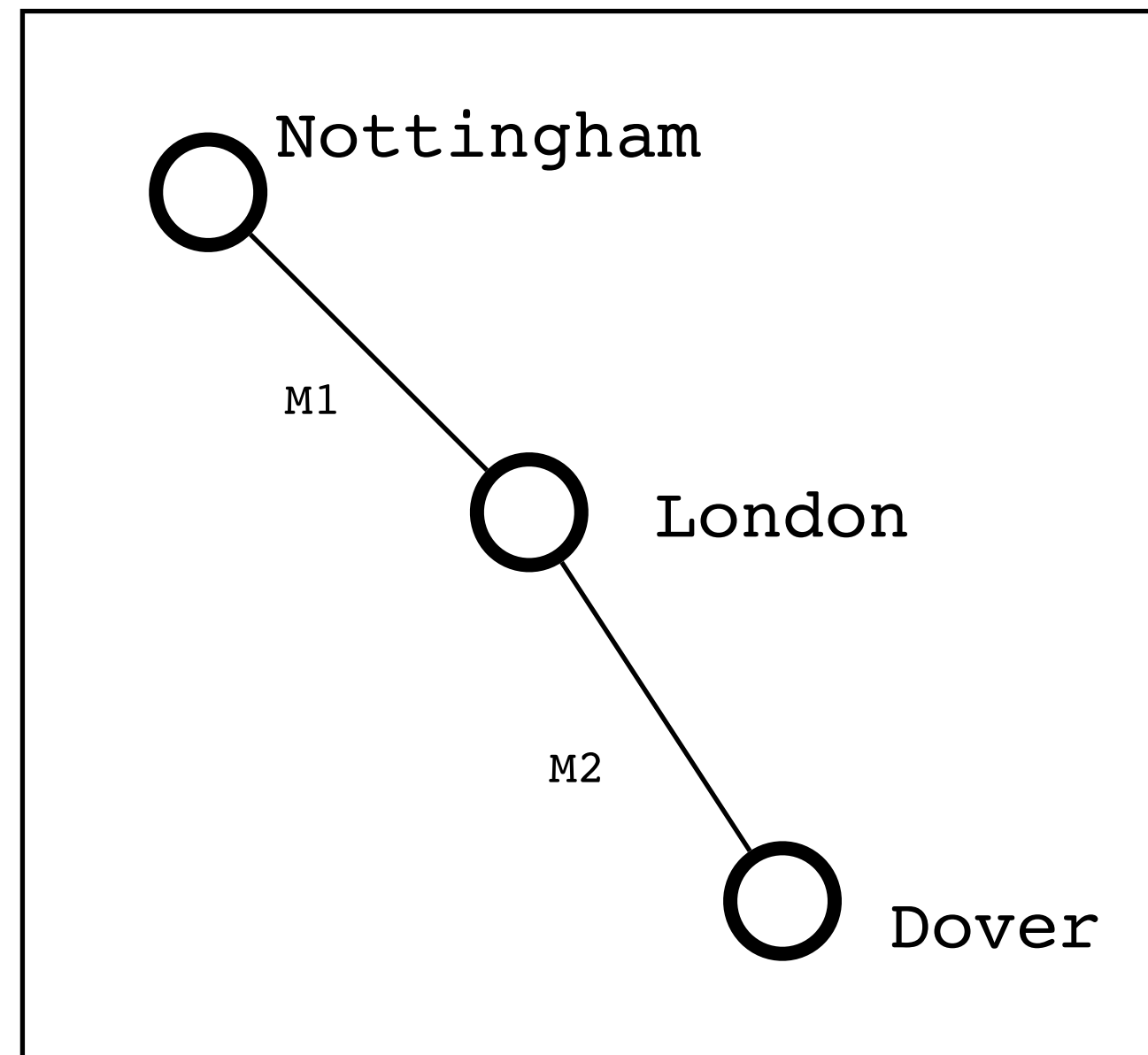
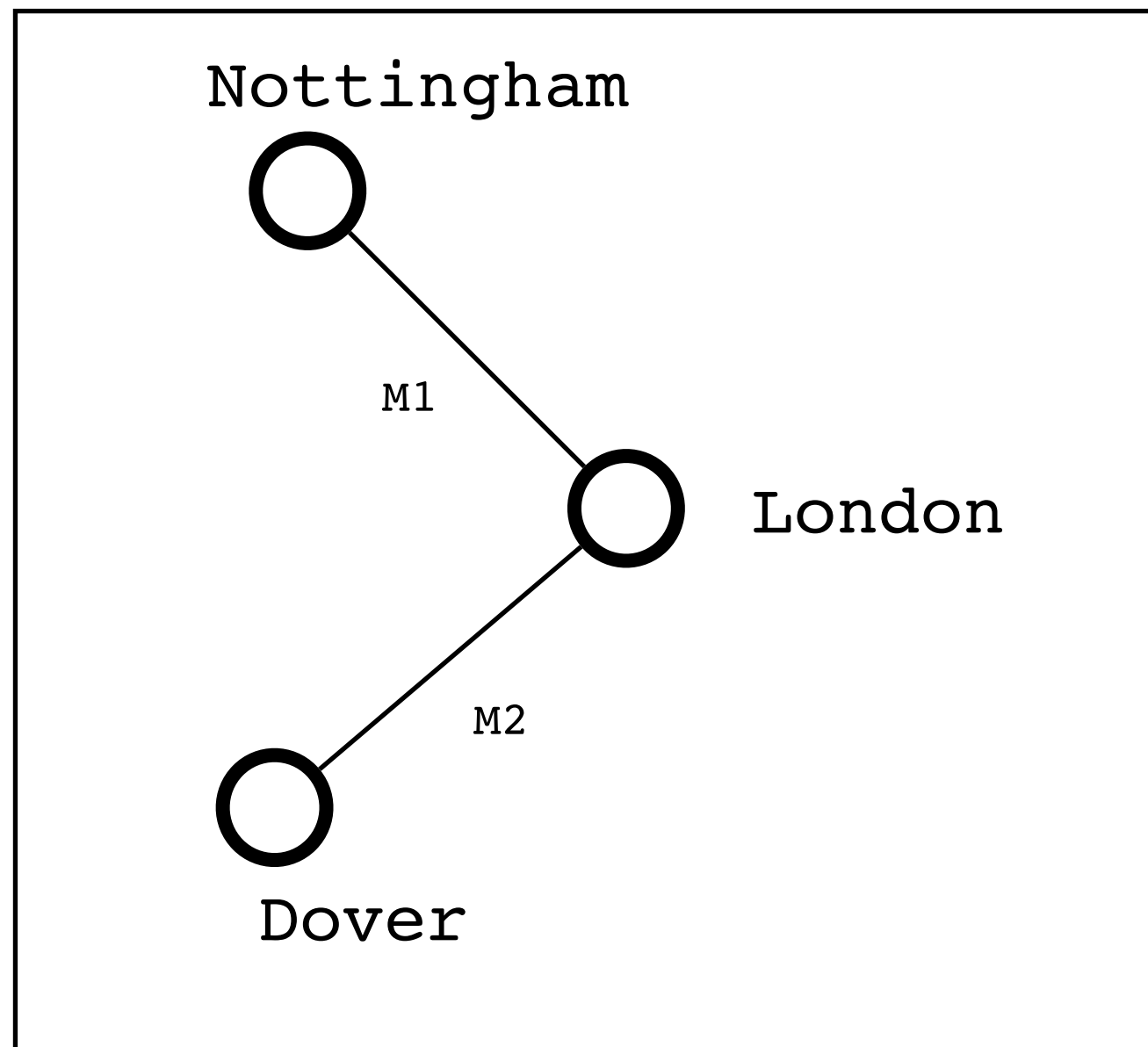

**3 GRAPHS
ARE THE
SAME**

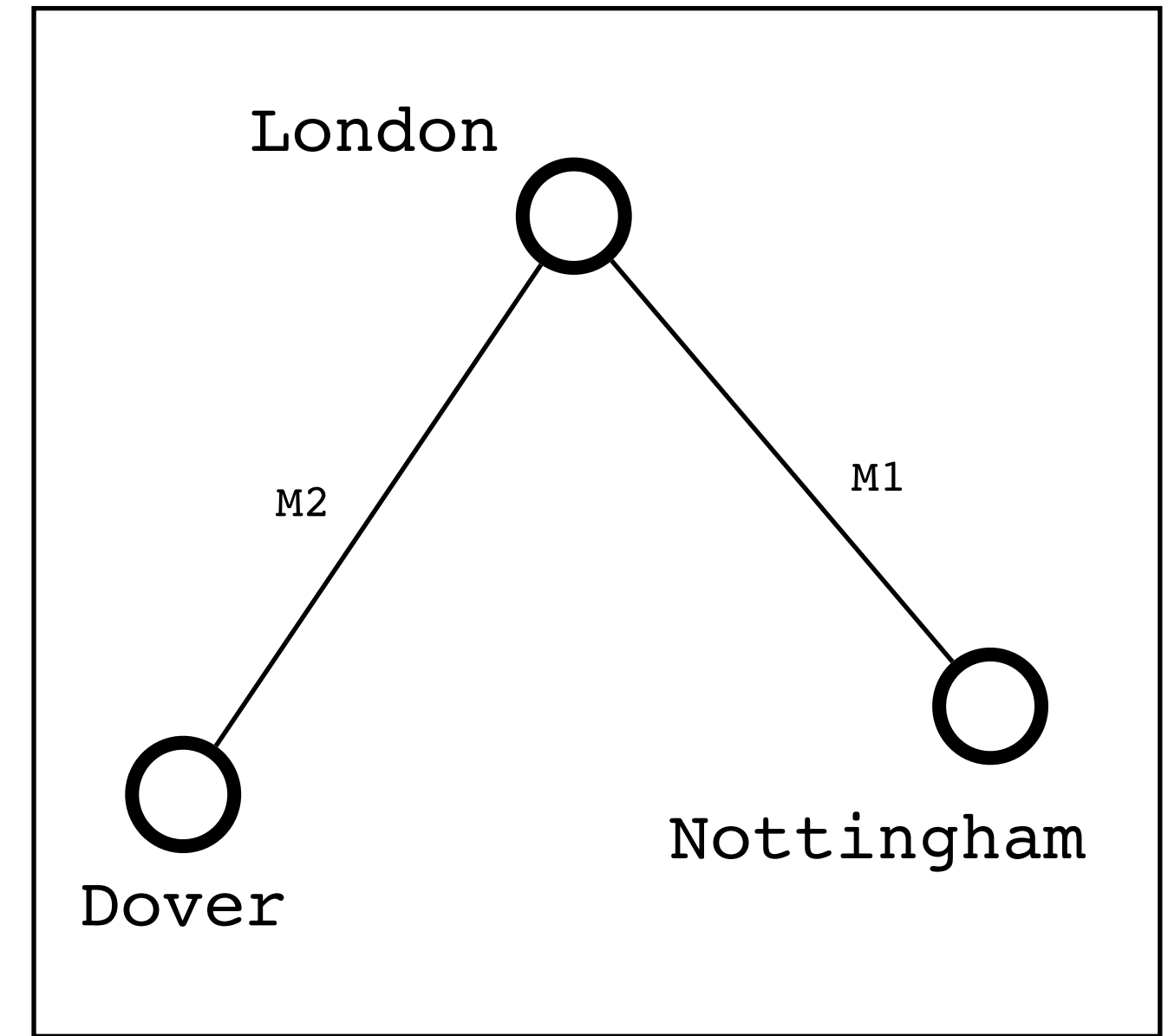
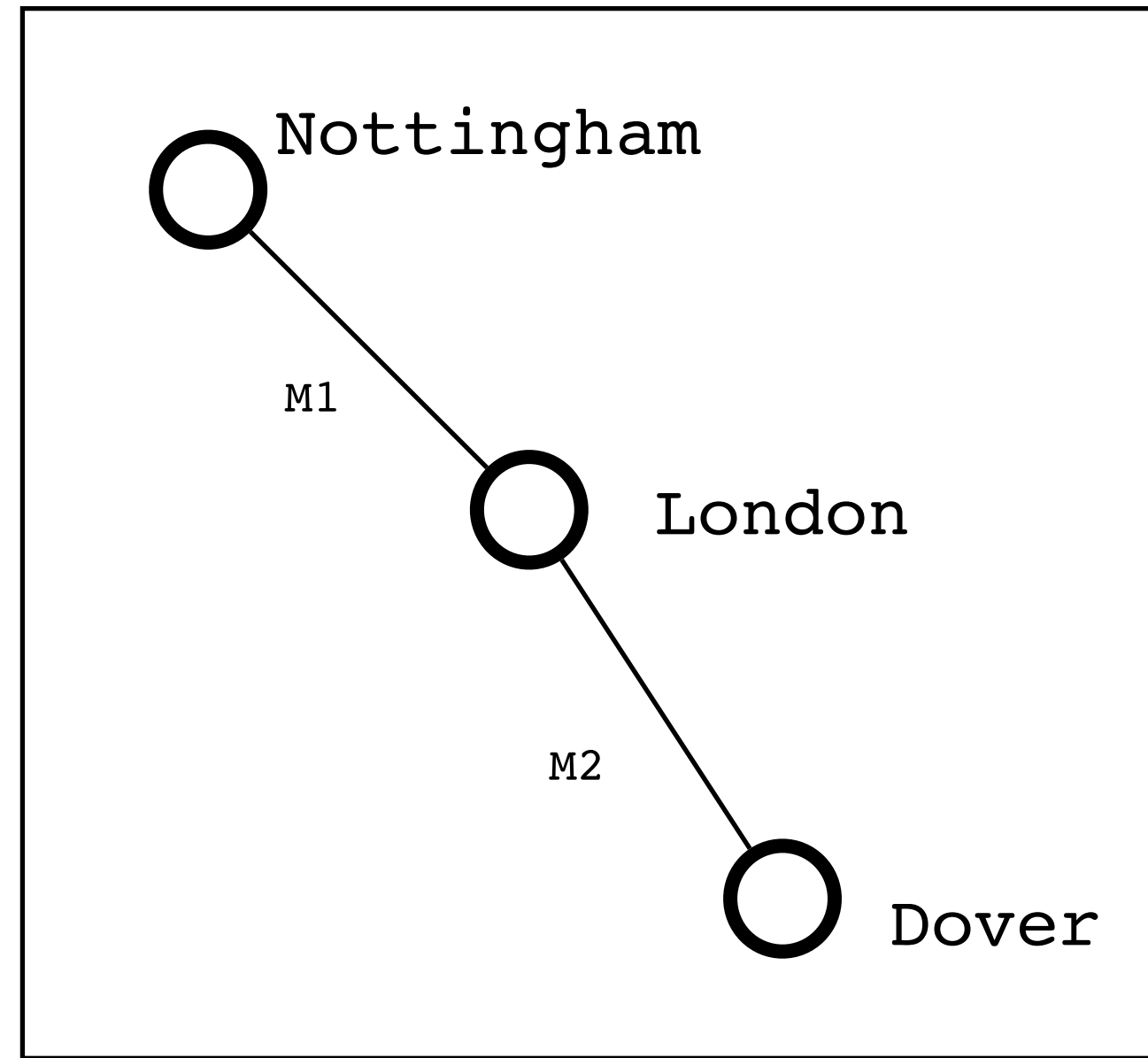
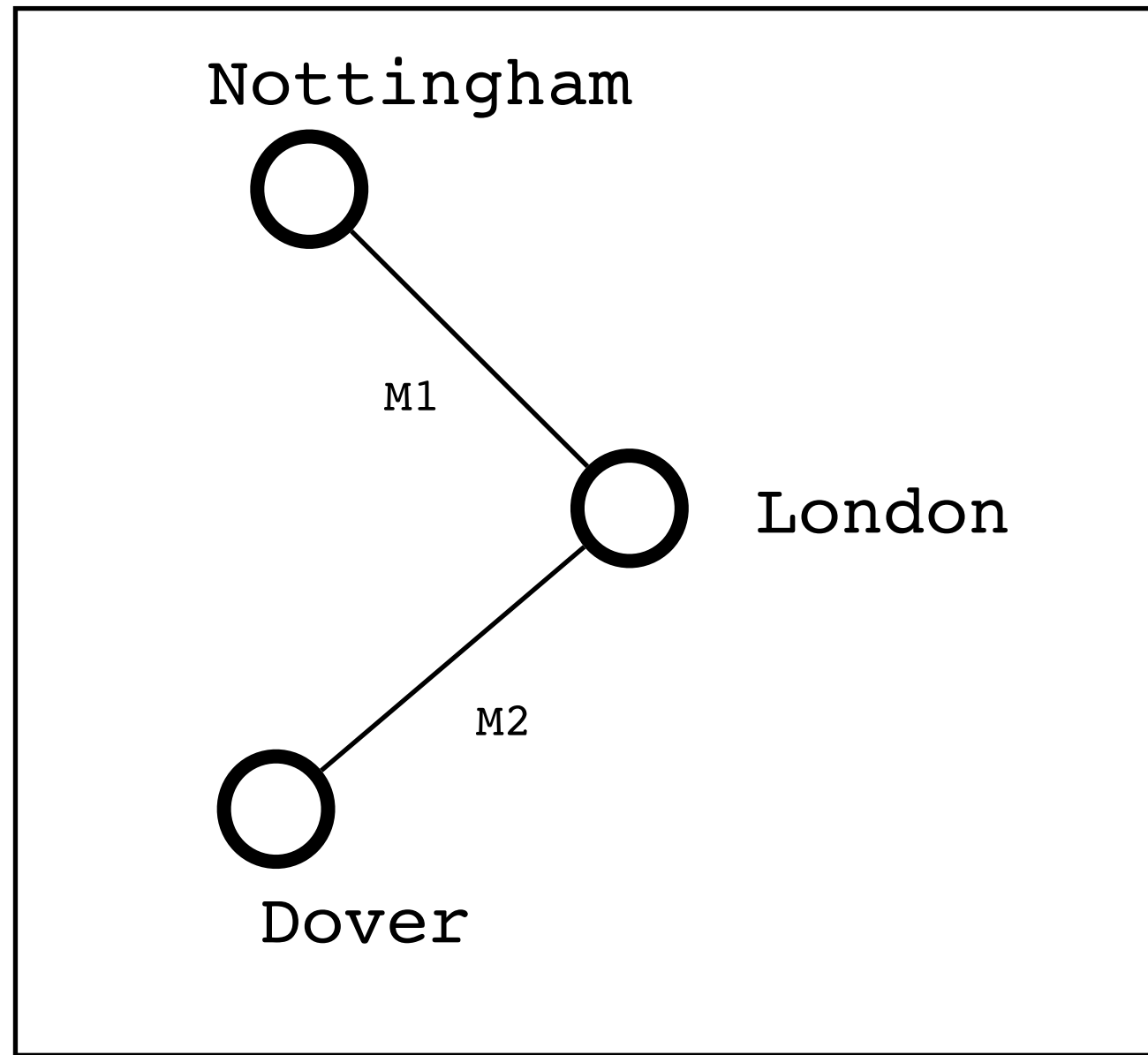

**3 MAPS
ARE
DIFFERENT**

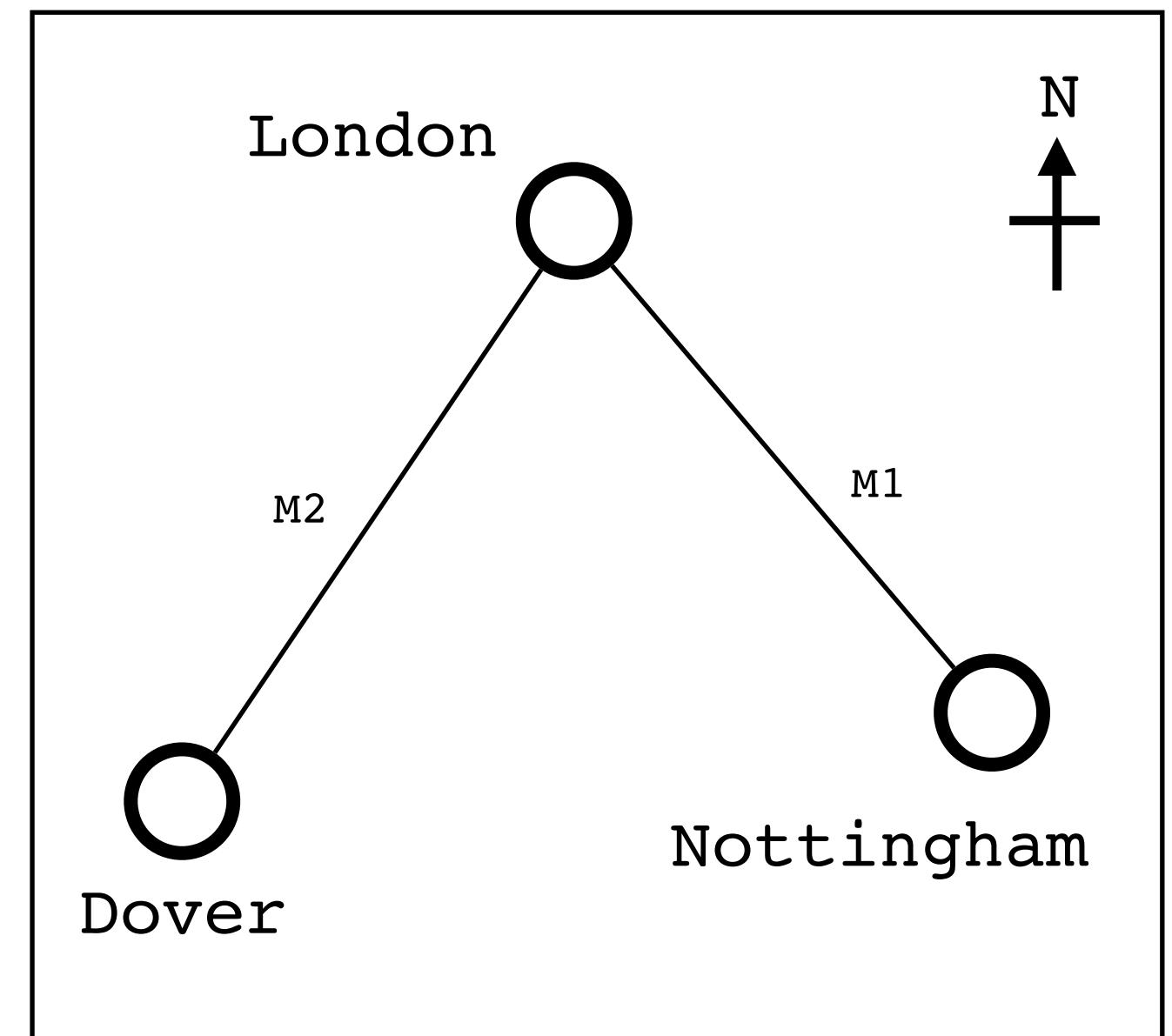
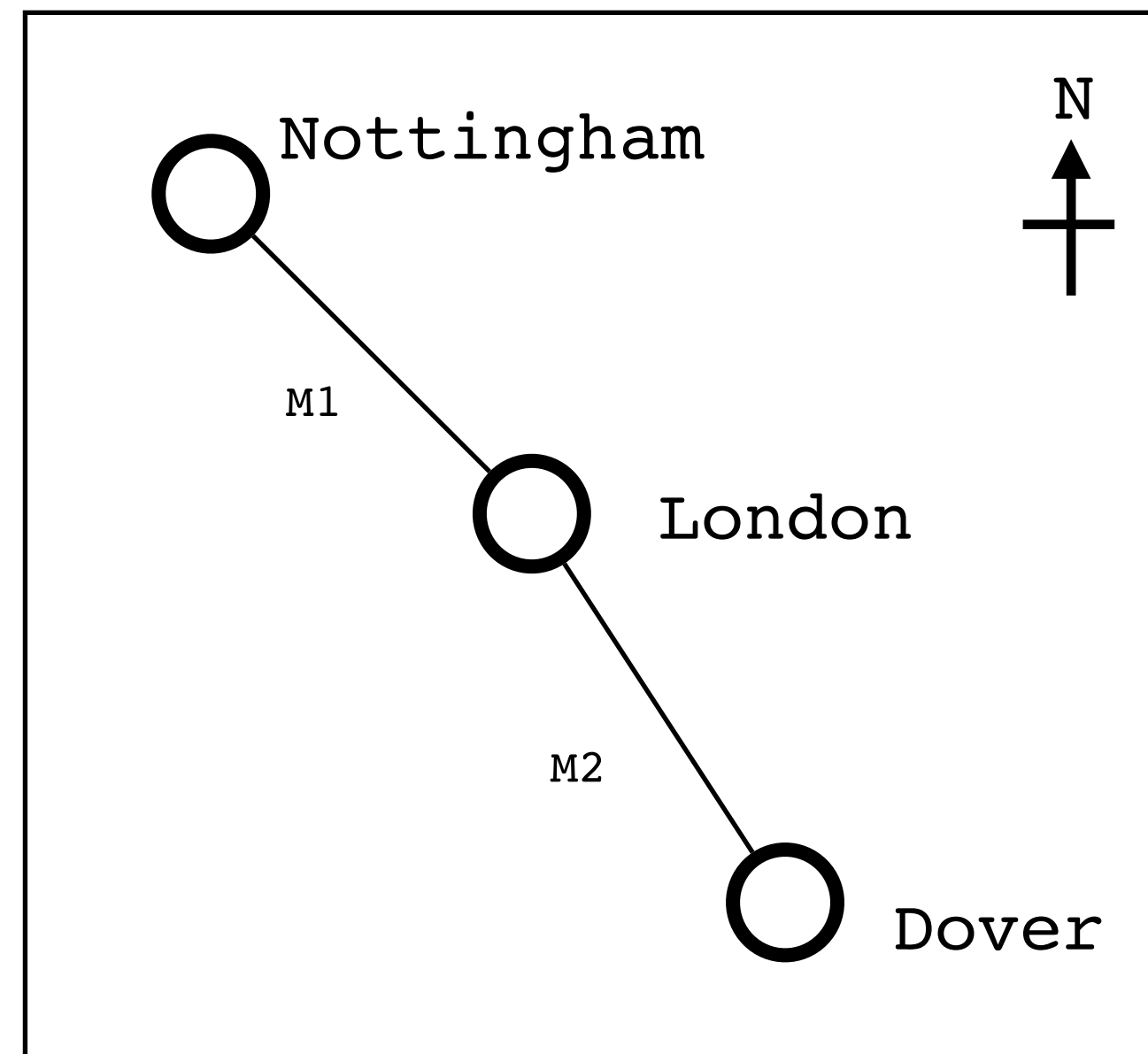
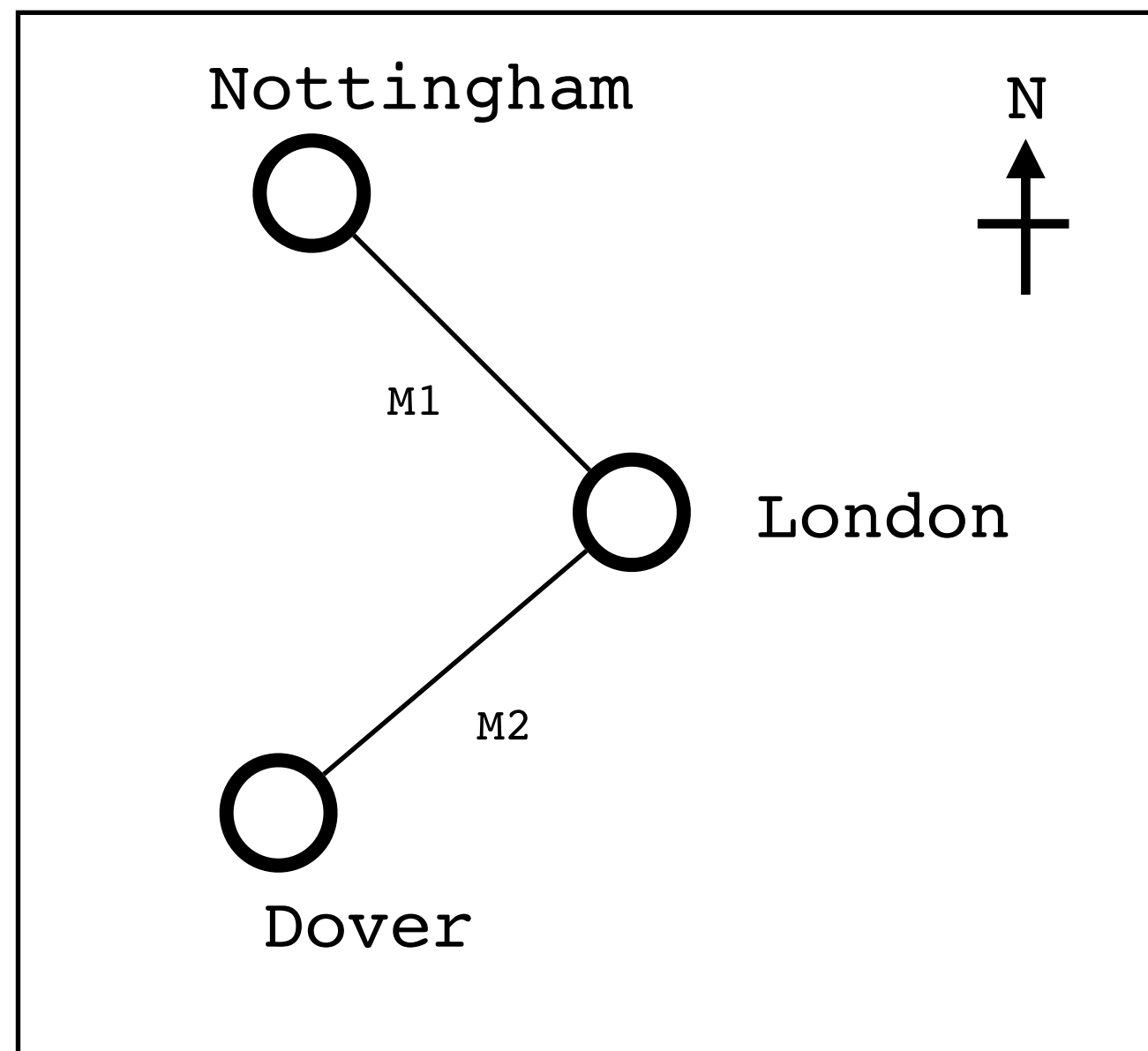

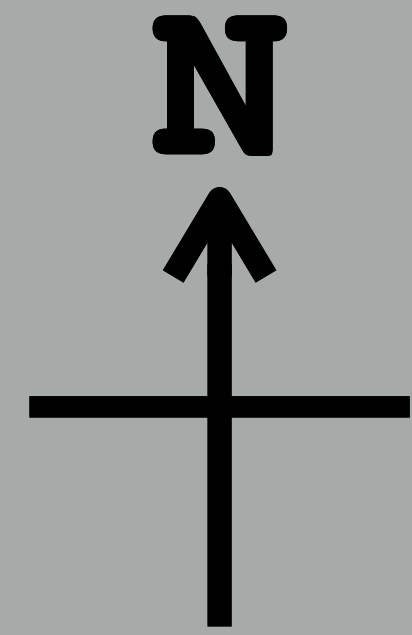

Artemisium

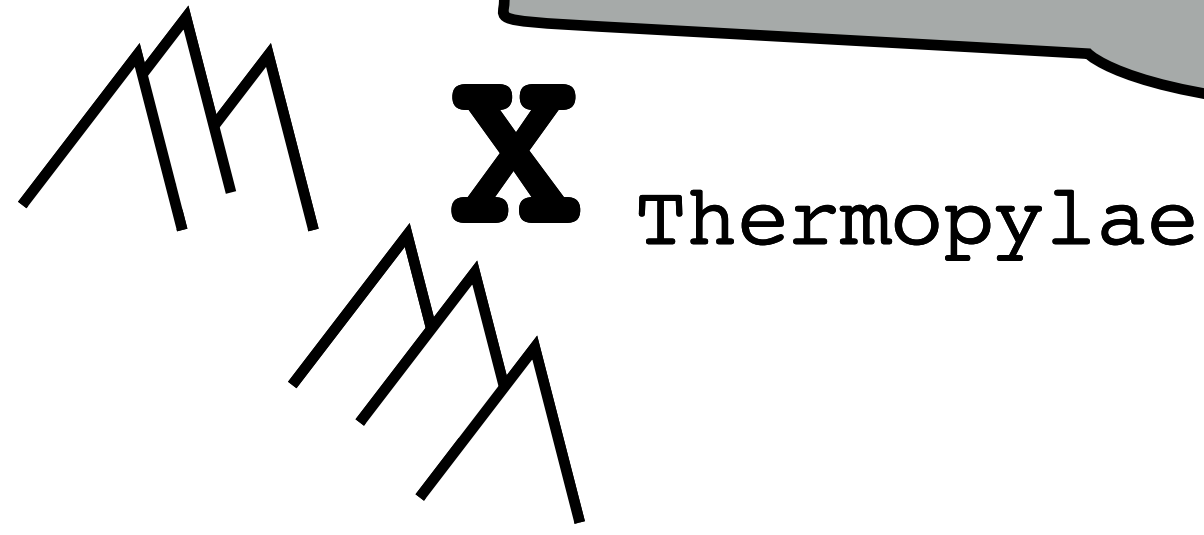

Thermopylae

Thebes **X**

Athens **X**

Space has
meaning!

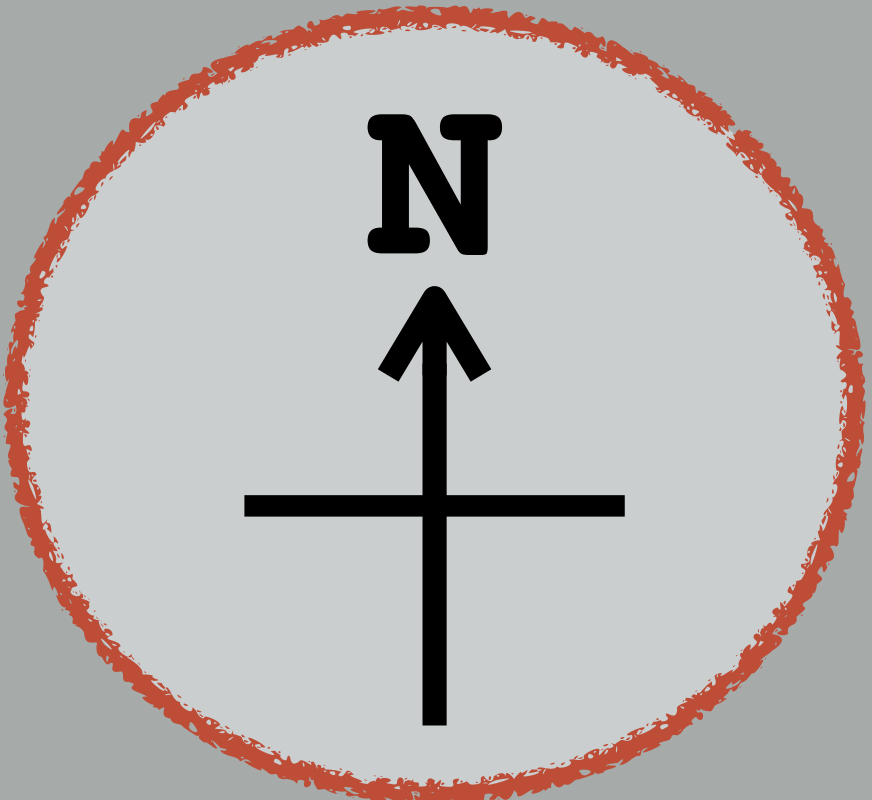

Artemisium



X Thermopylae

Thebes **X**

Athens **X**

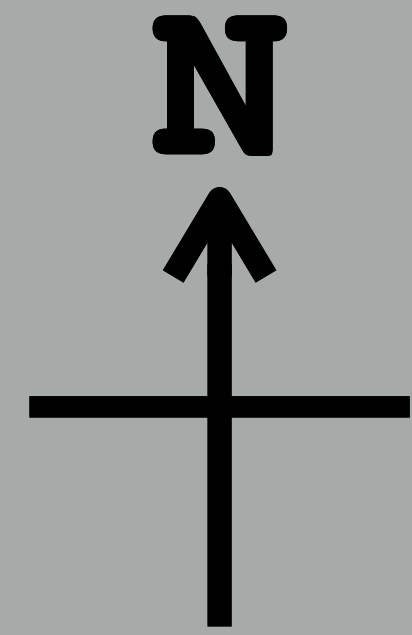

Artemisium

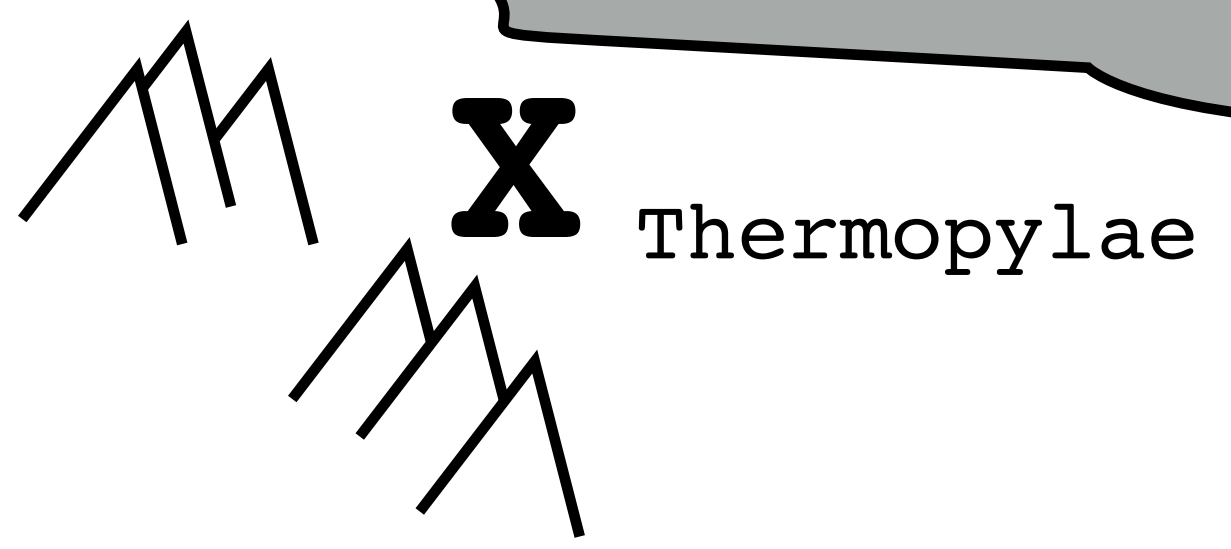

Thermopylae



Thebes

Athens

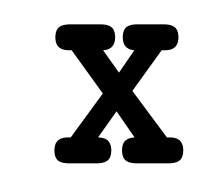

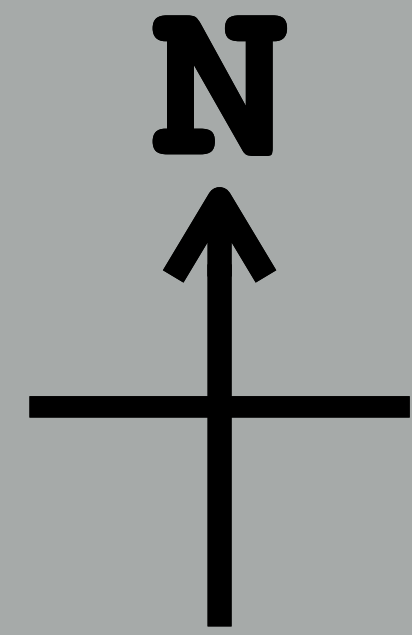

Artemisium

X Thermopylae

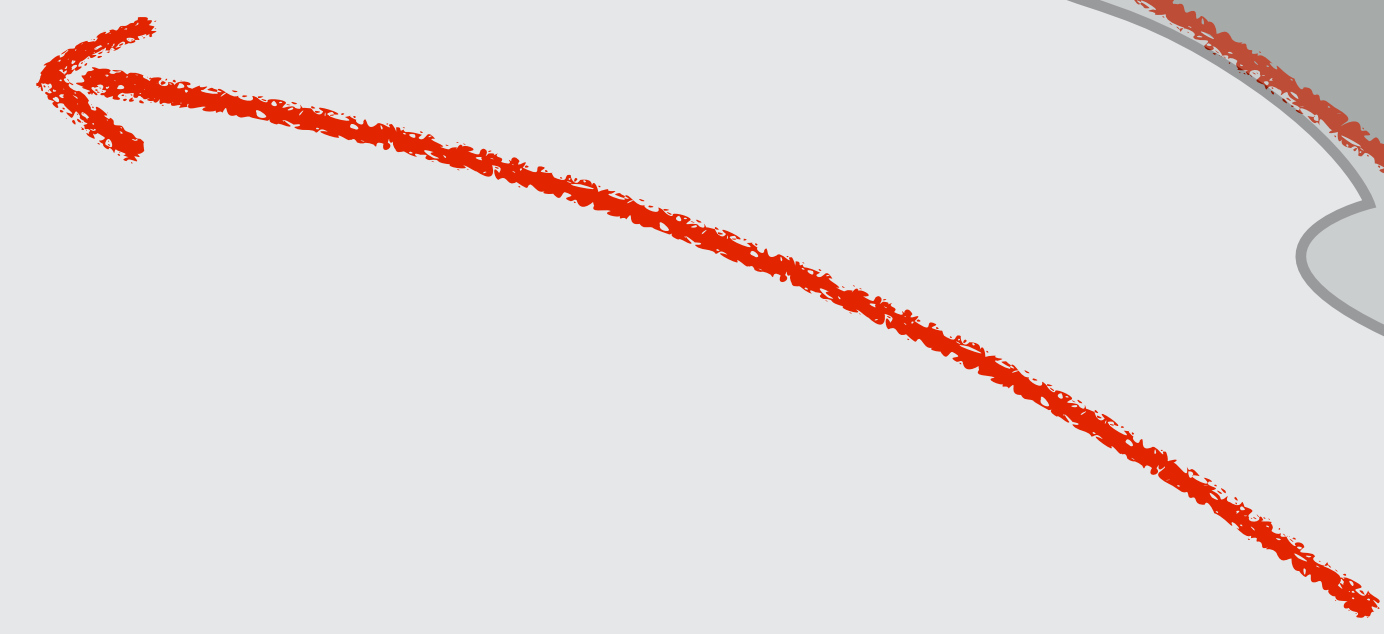
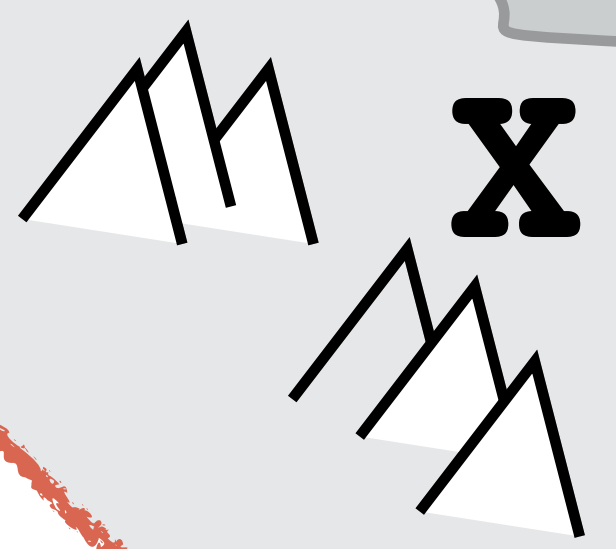

Thebes **X**

Athens **X**

Systems Map

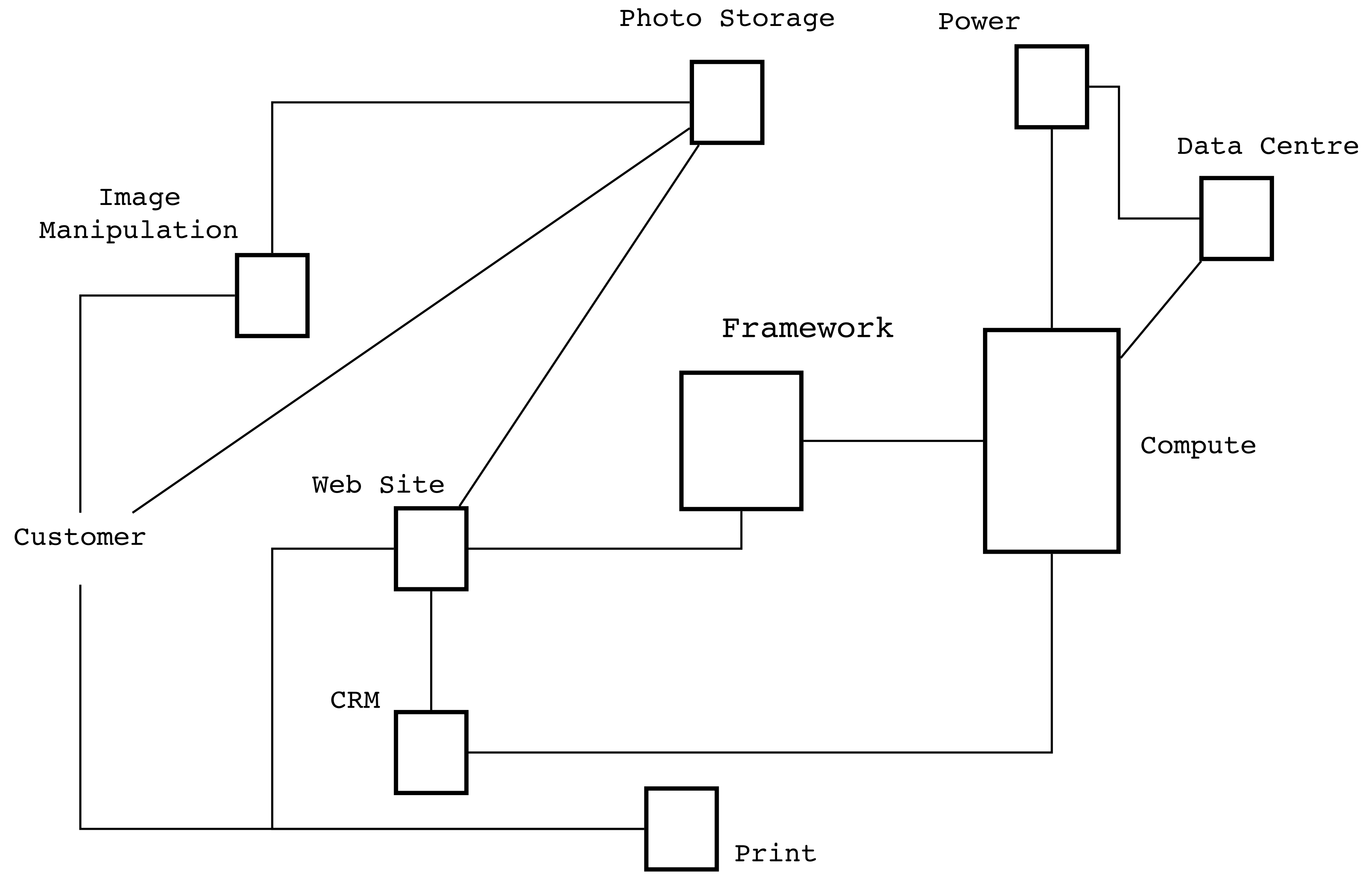

Systems Map

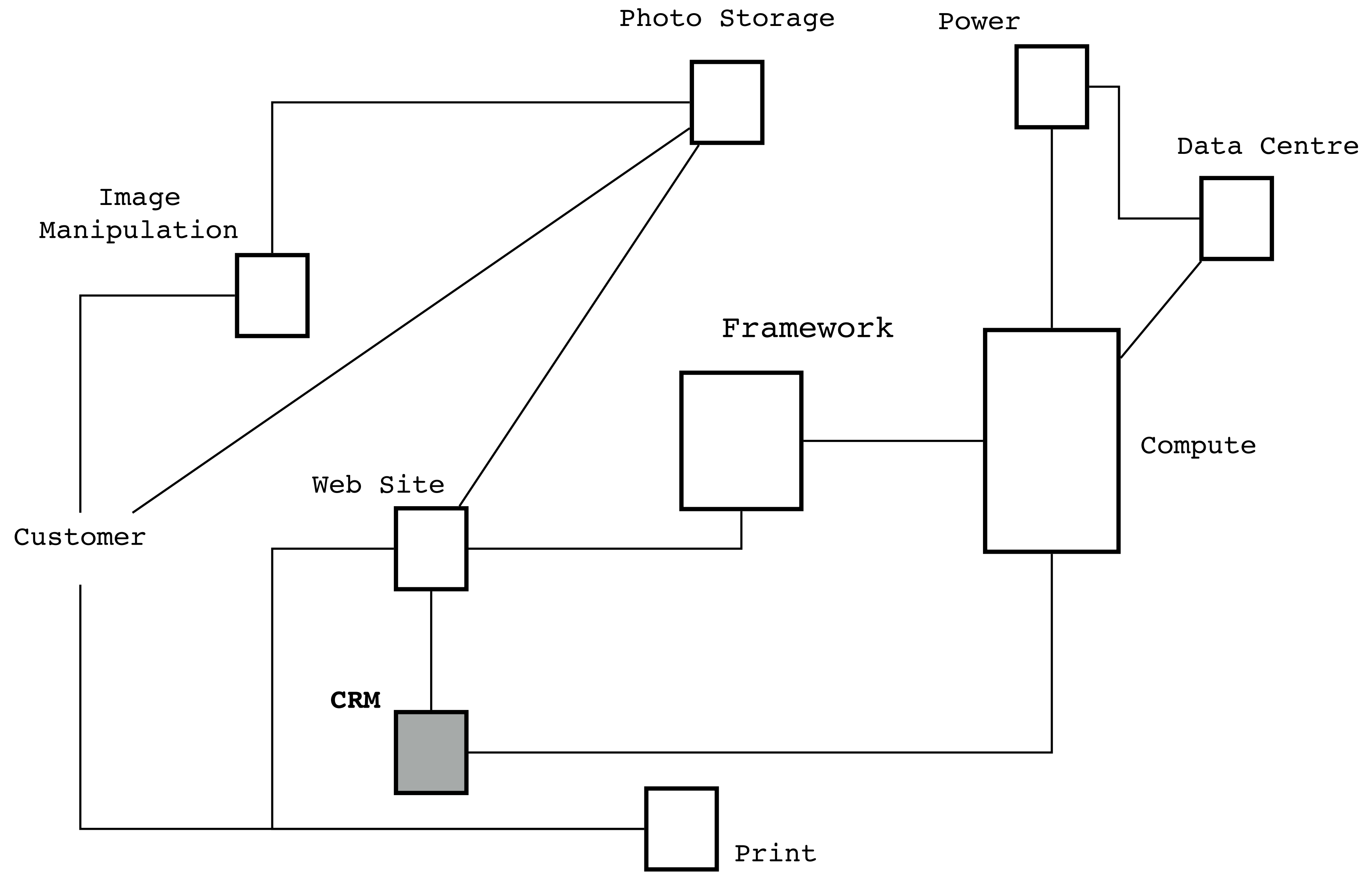

Systems Map

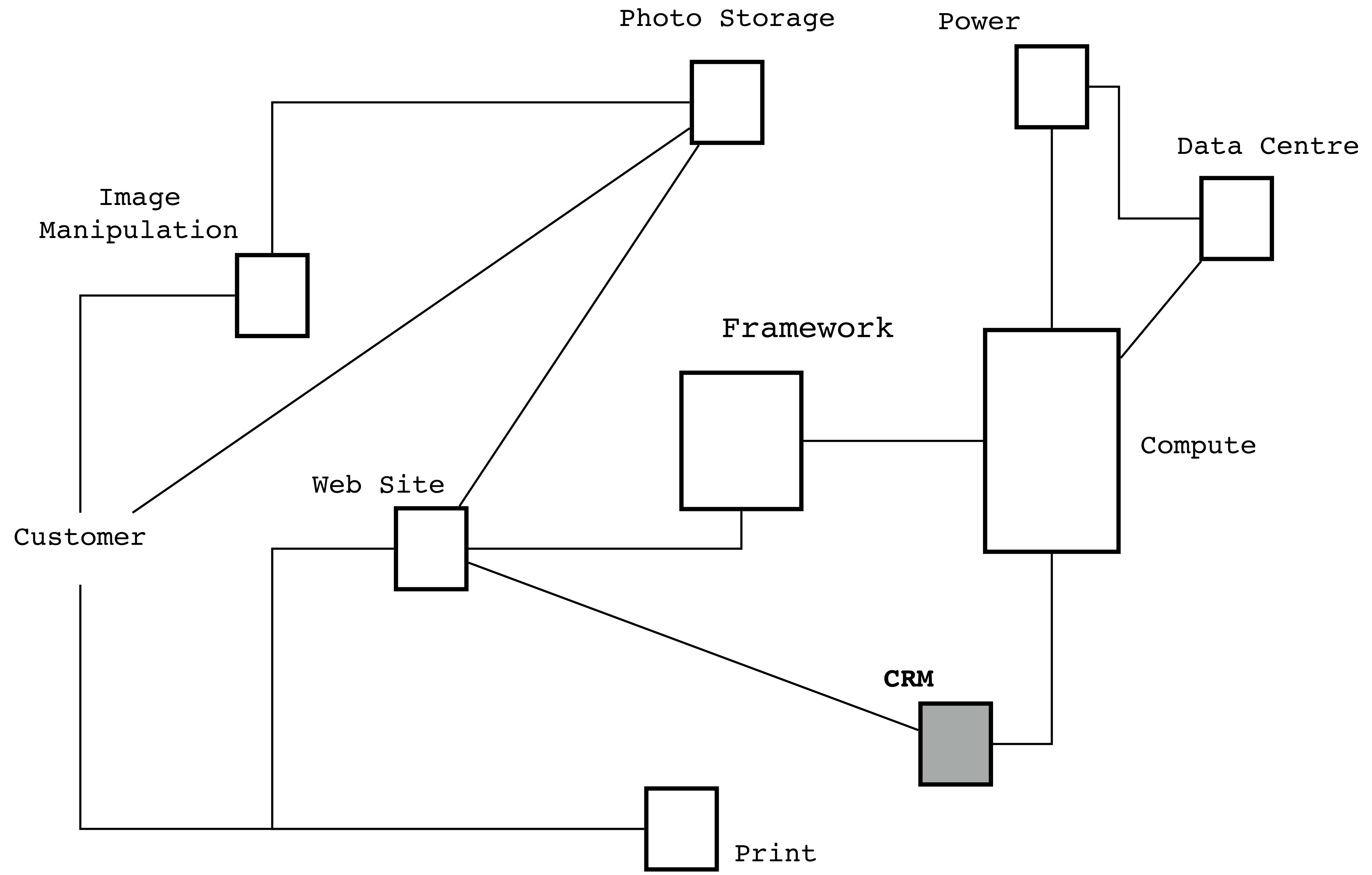



HOW TO CREATE A MAP?

Systems Diagram

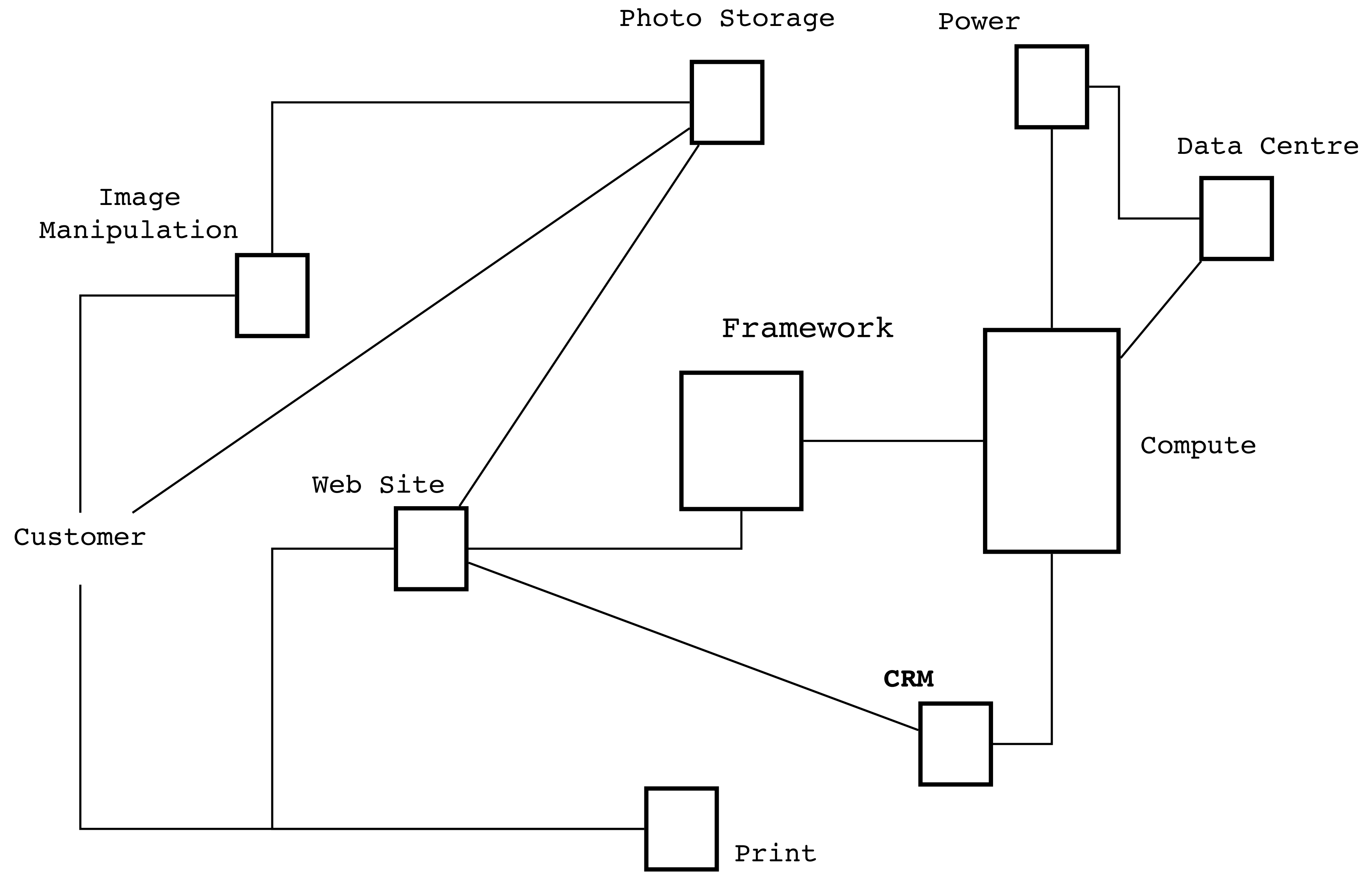

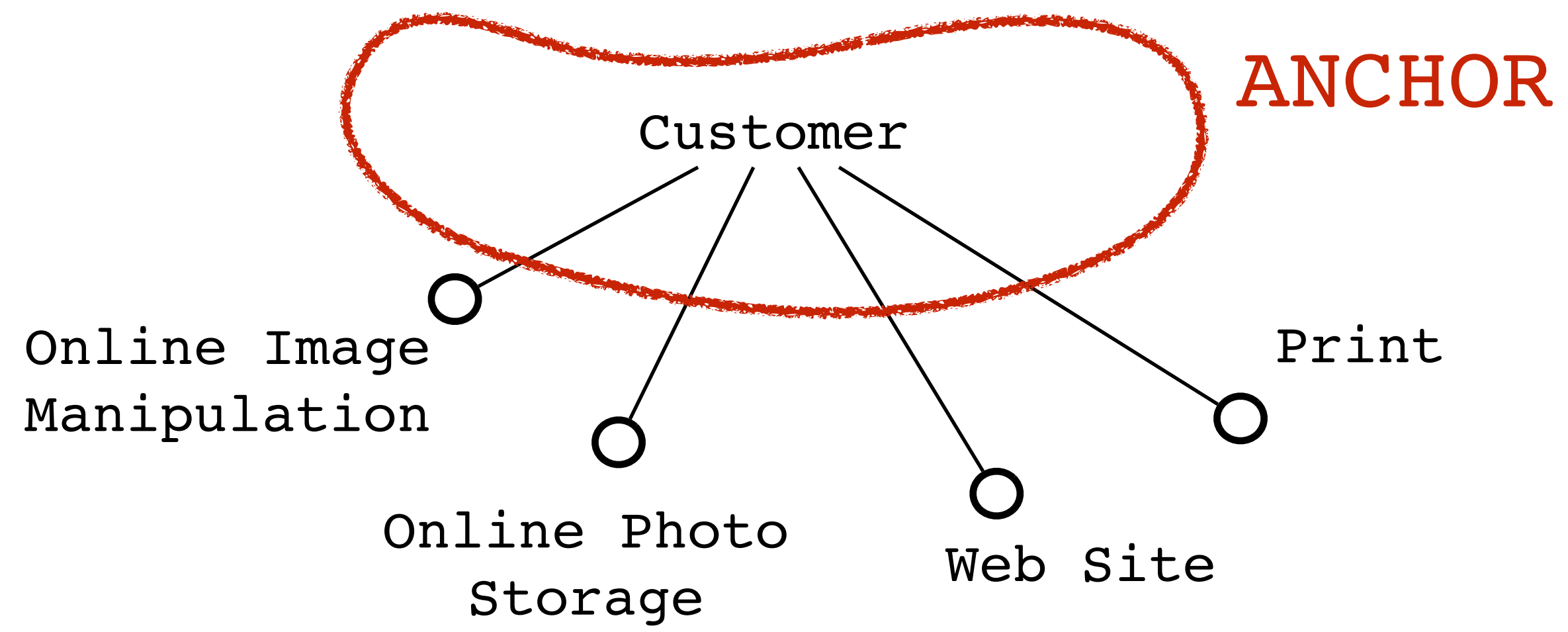

Visible
Value Chain
Invisible

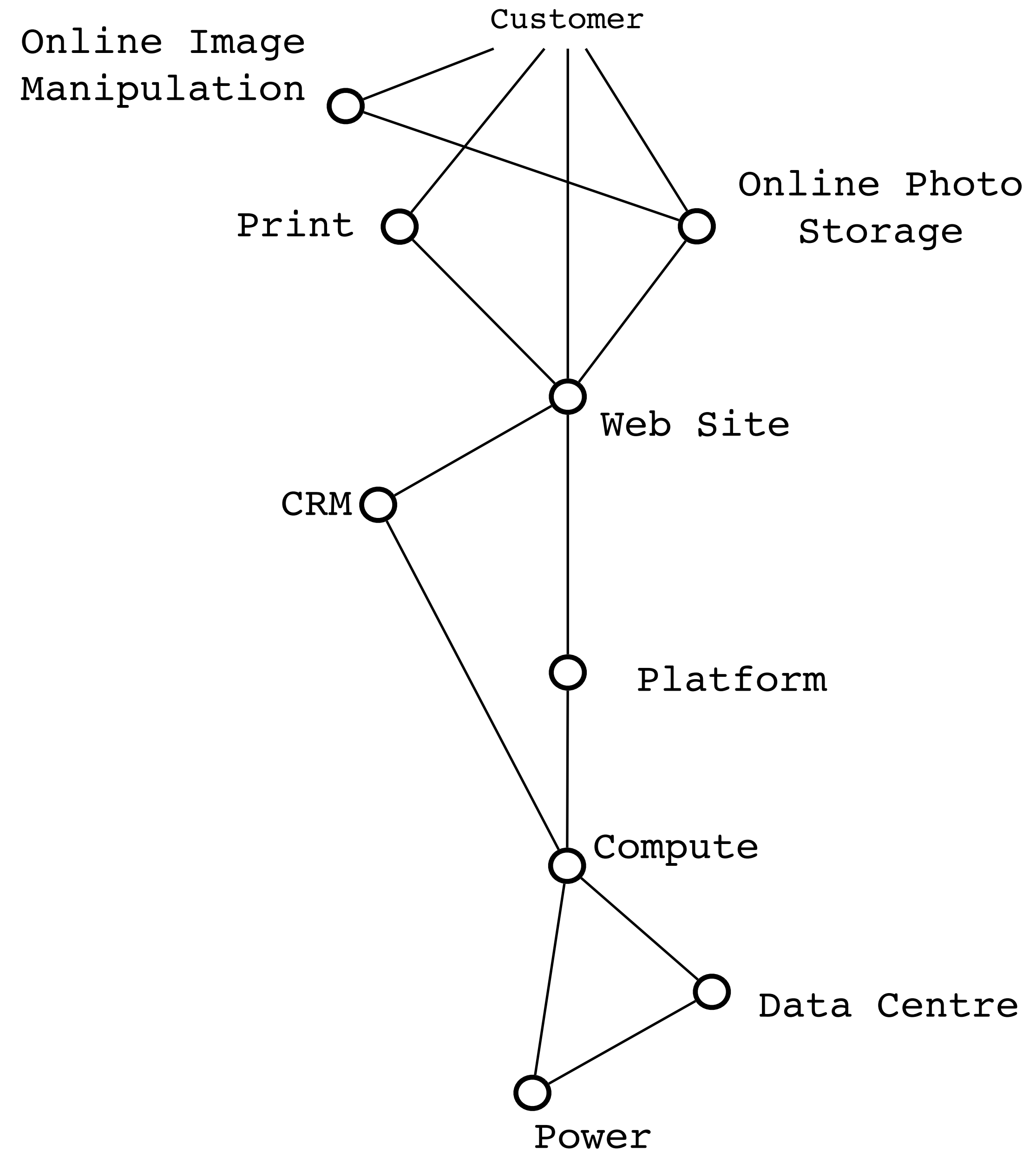

POSITION
(VISIBILITY)



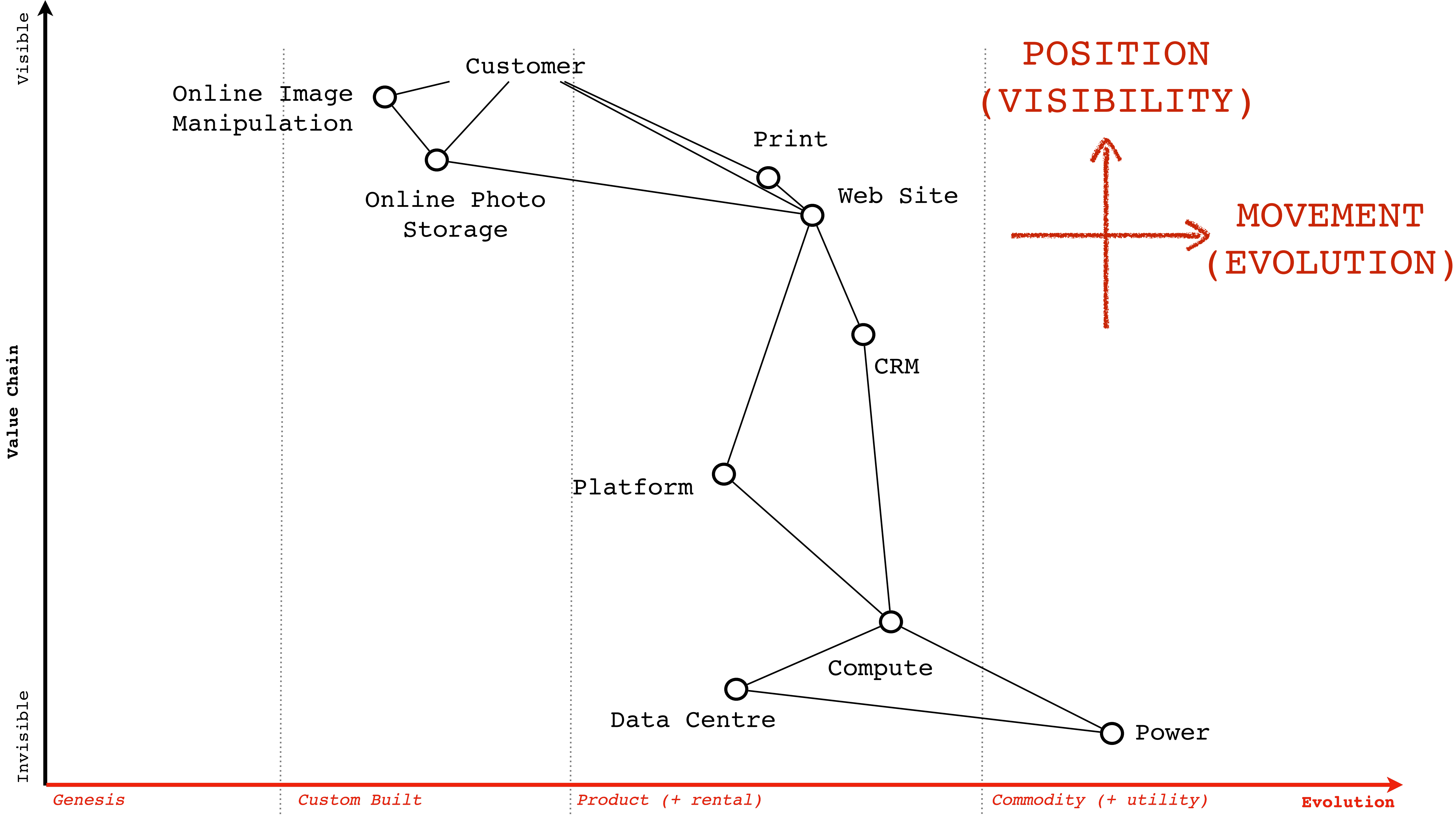

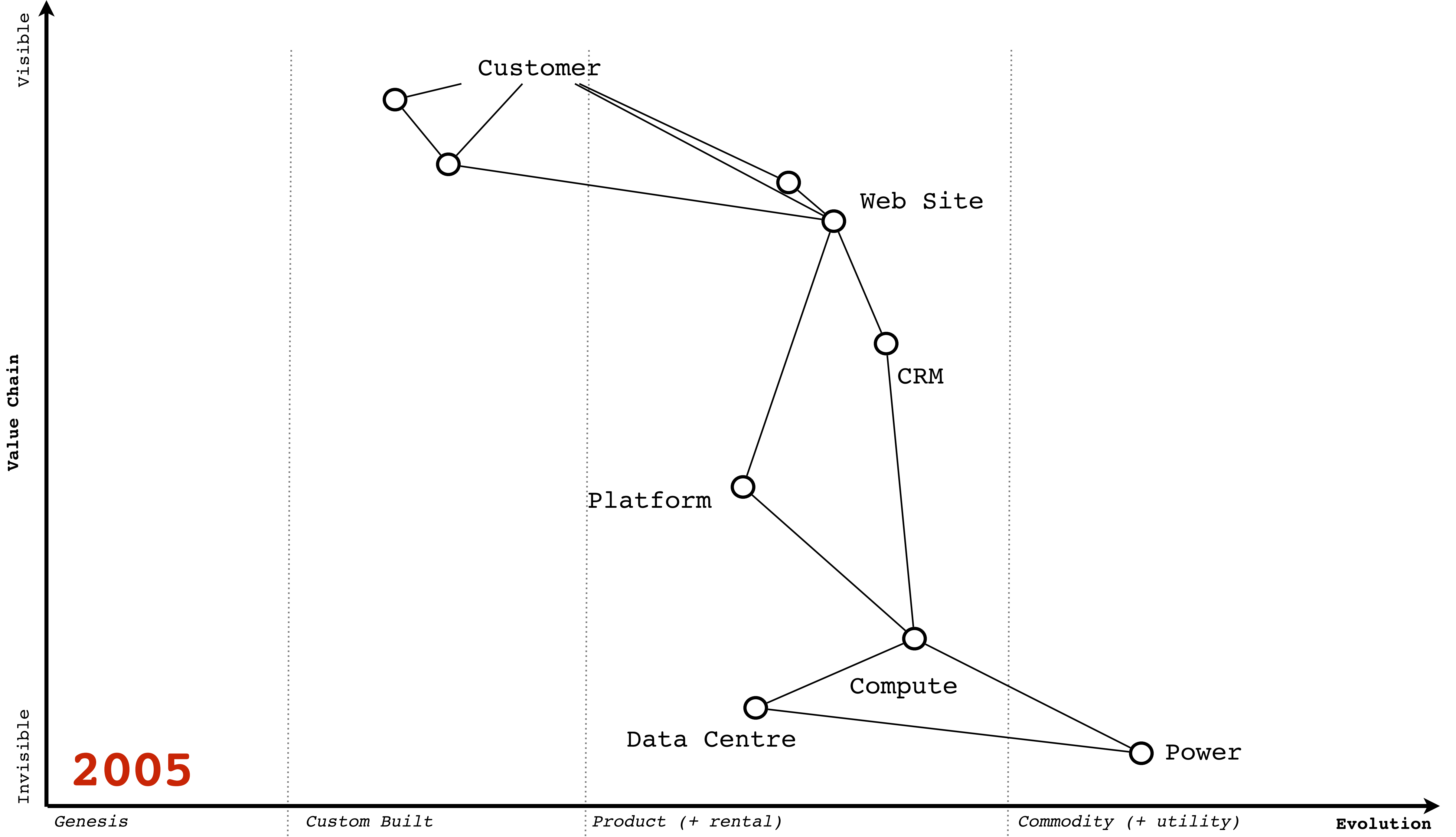

Strategy



Maps

Communication



Patterns

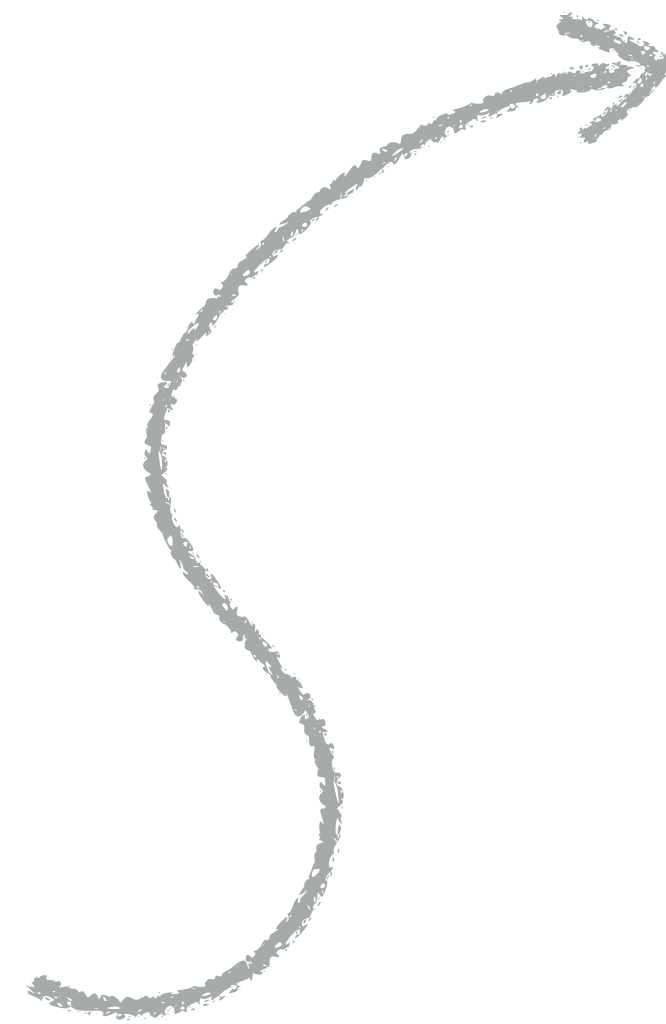

Anticipation



Organisation



Leadership

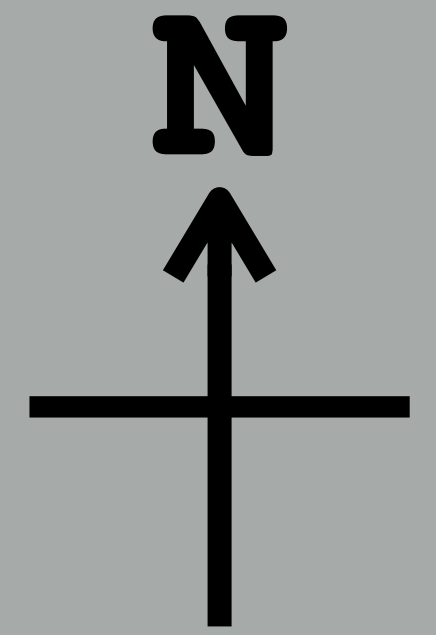

SERVERLESS





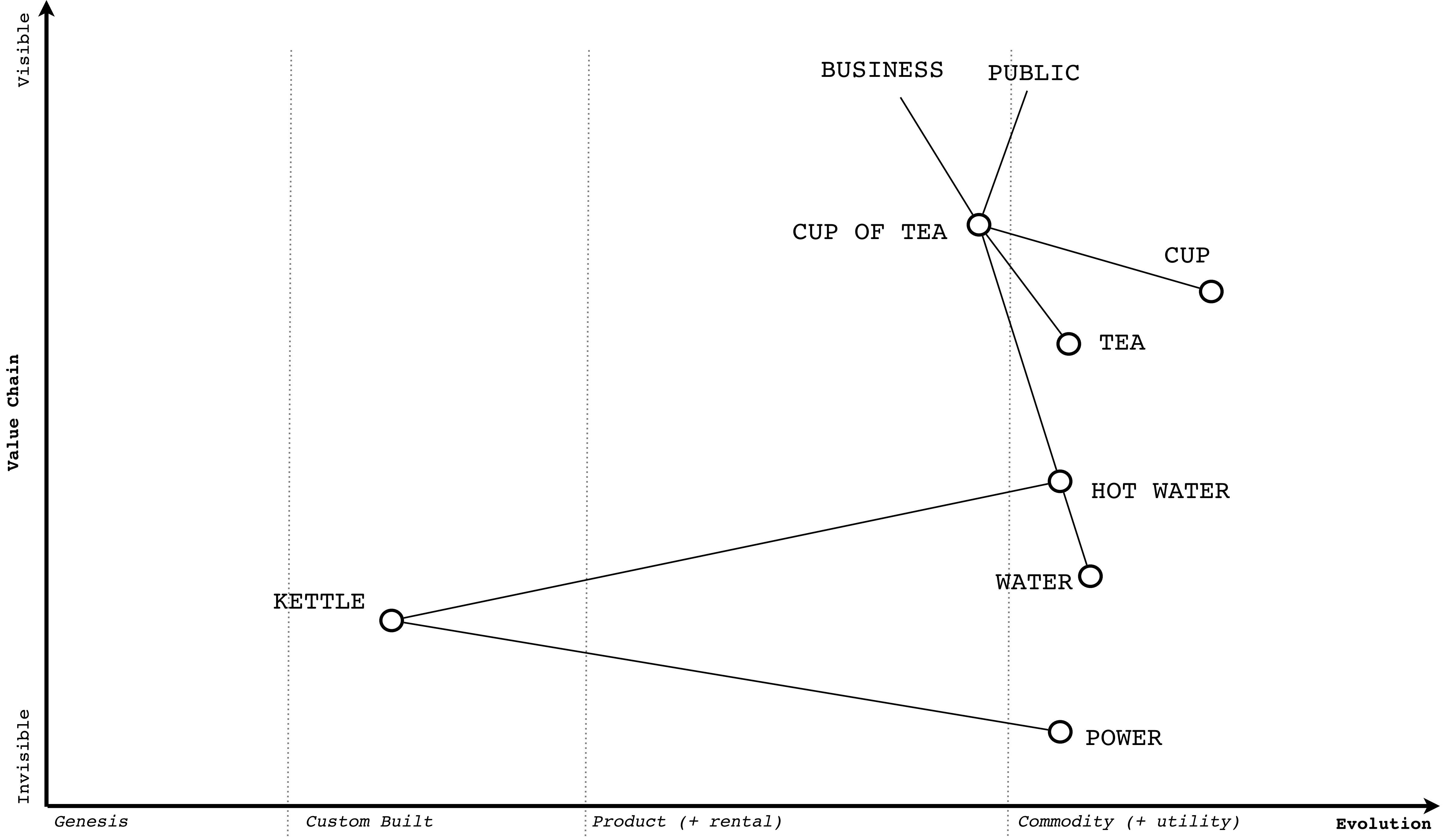

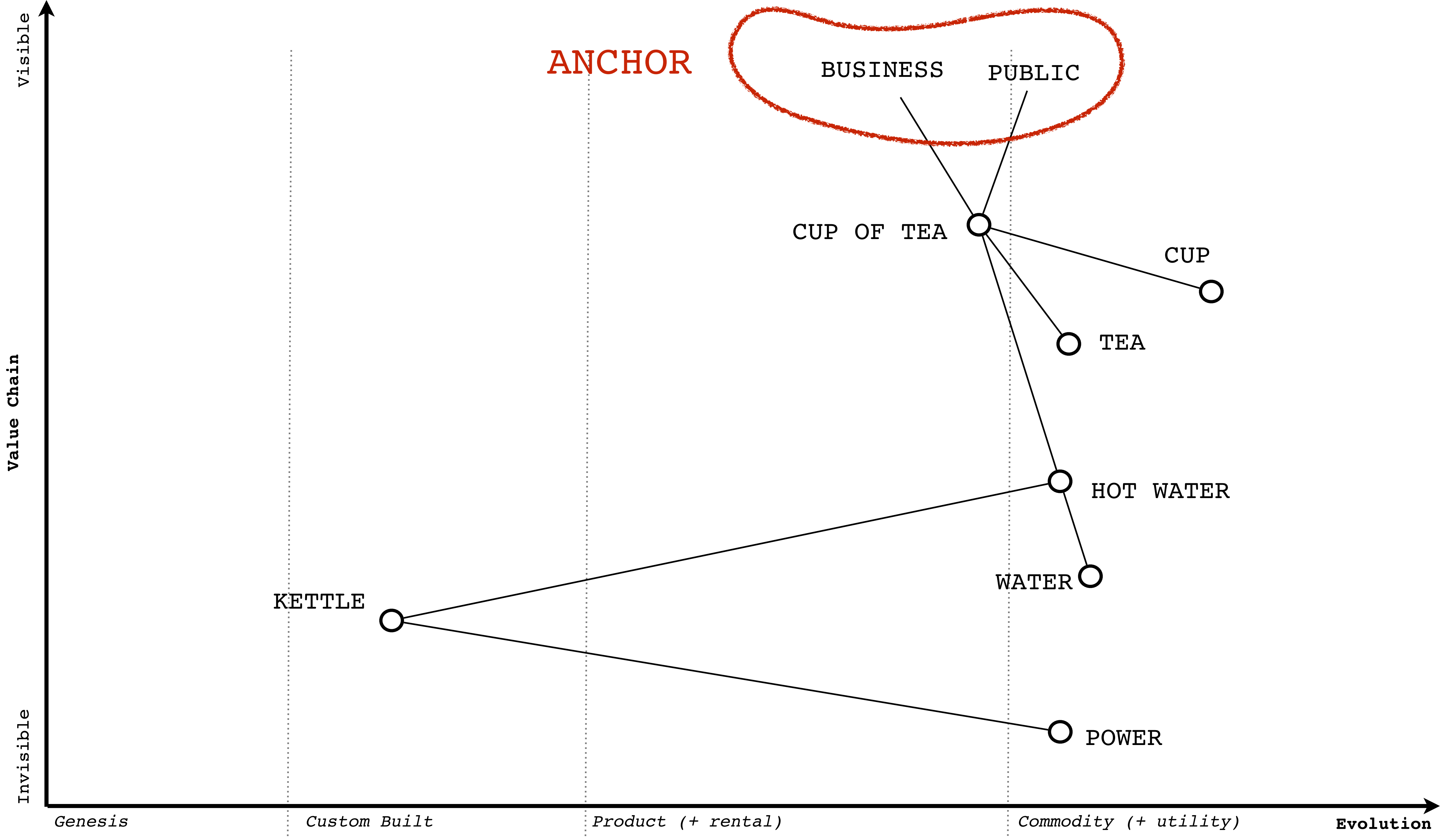

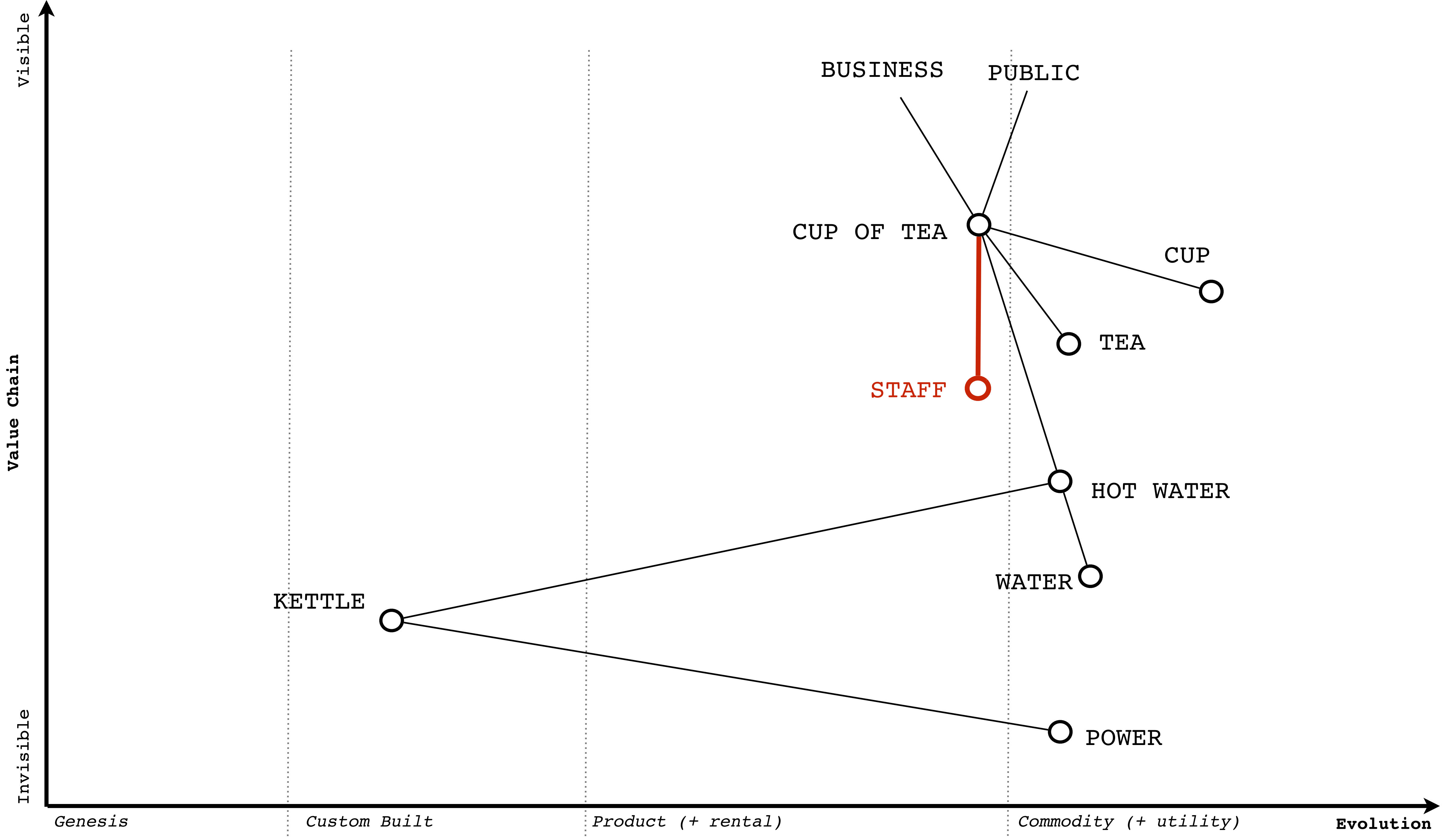

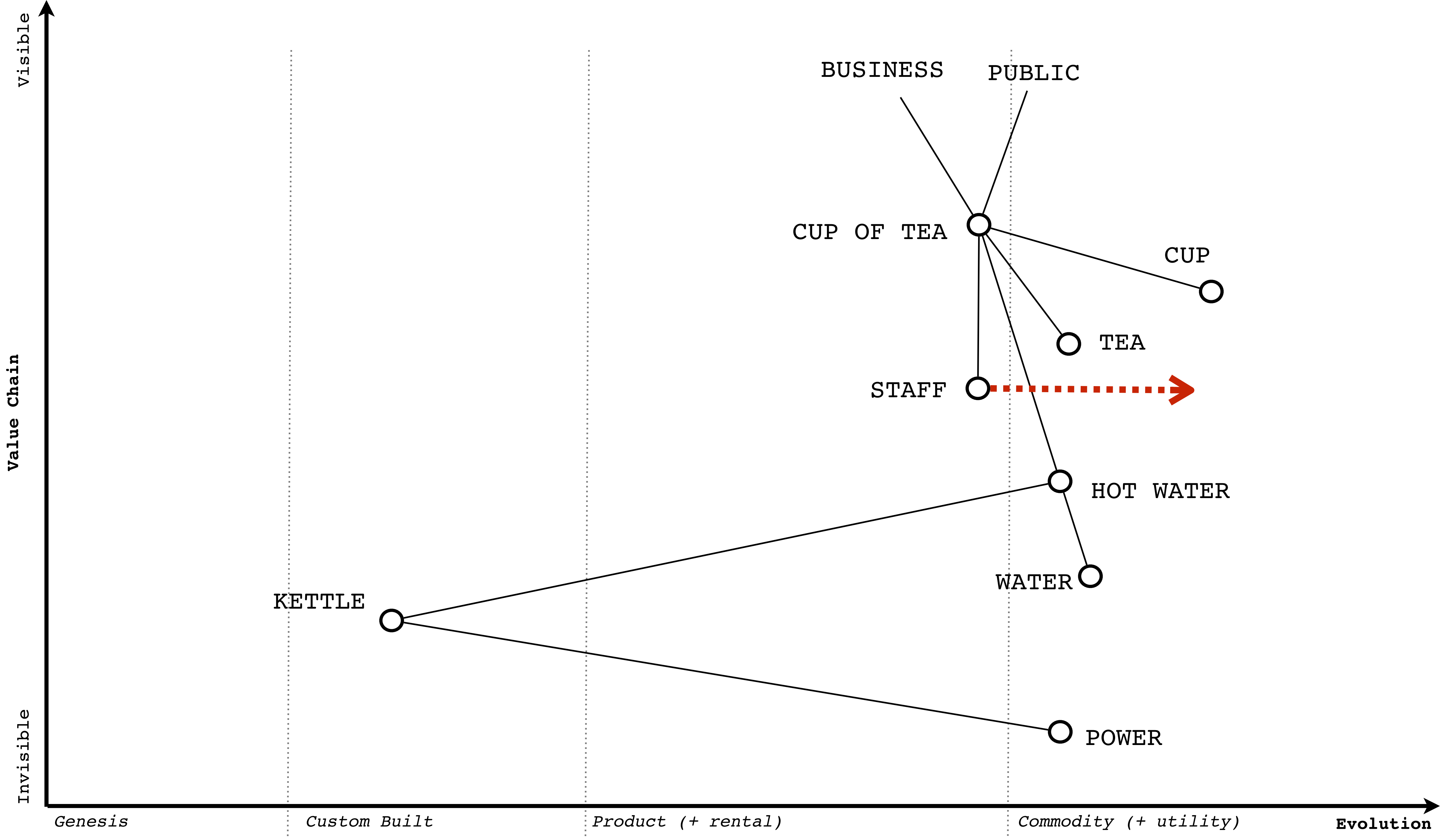

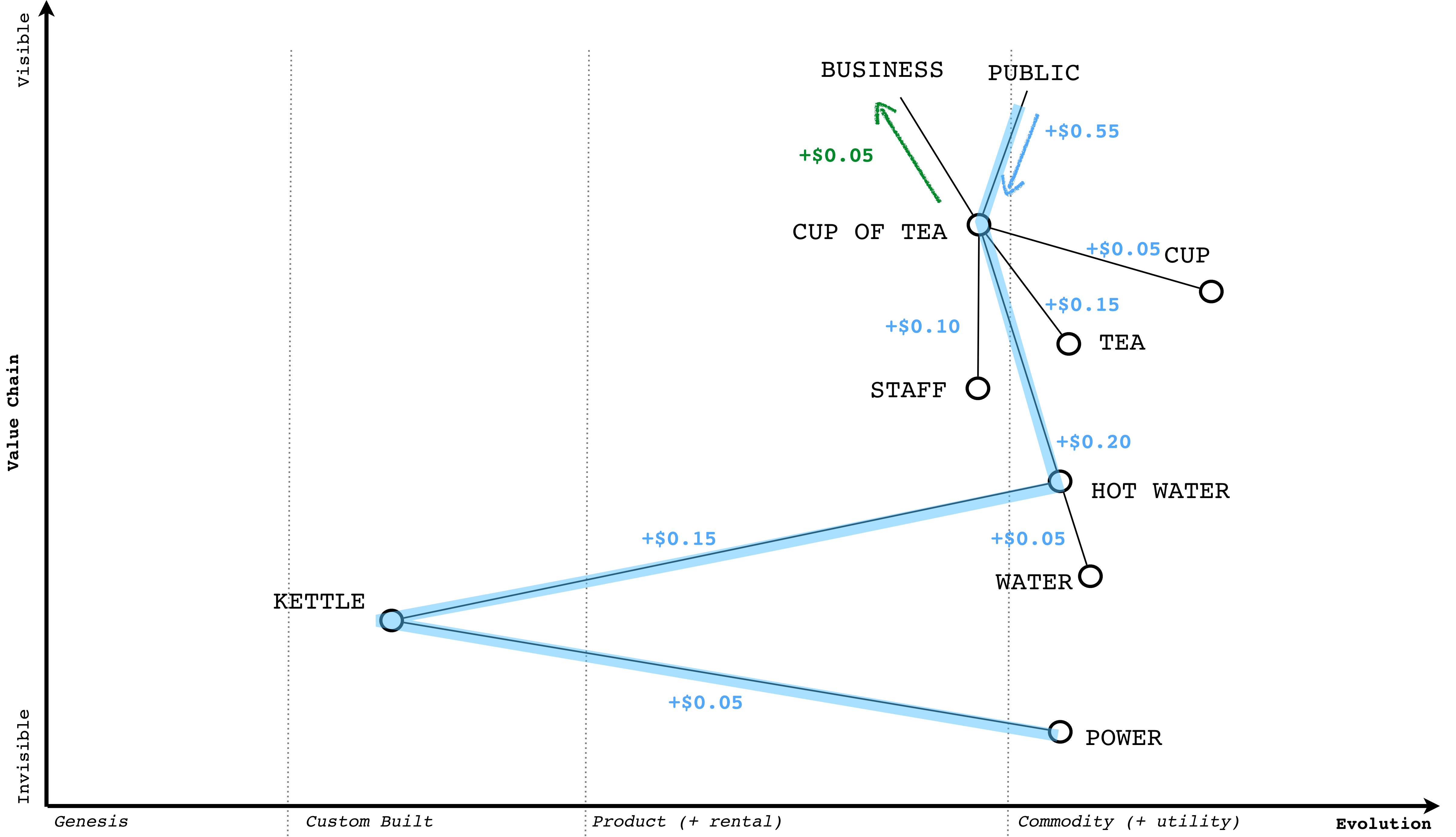

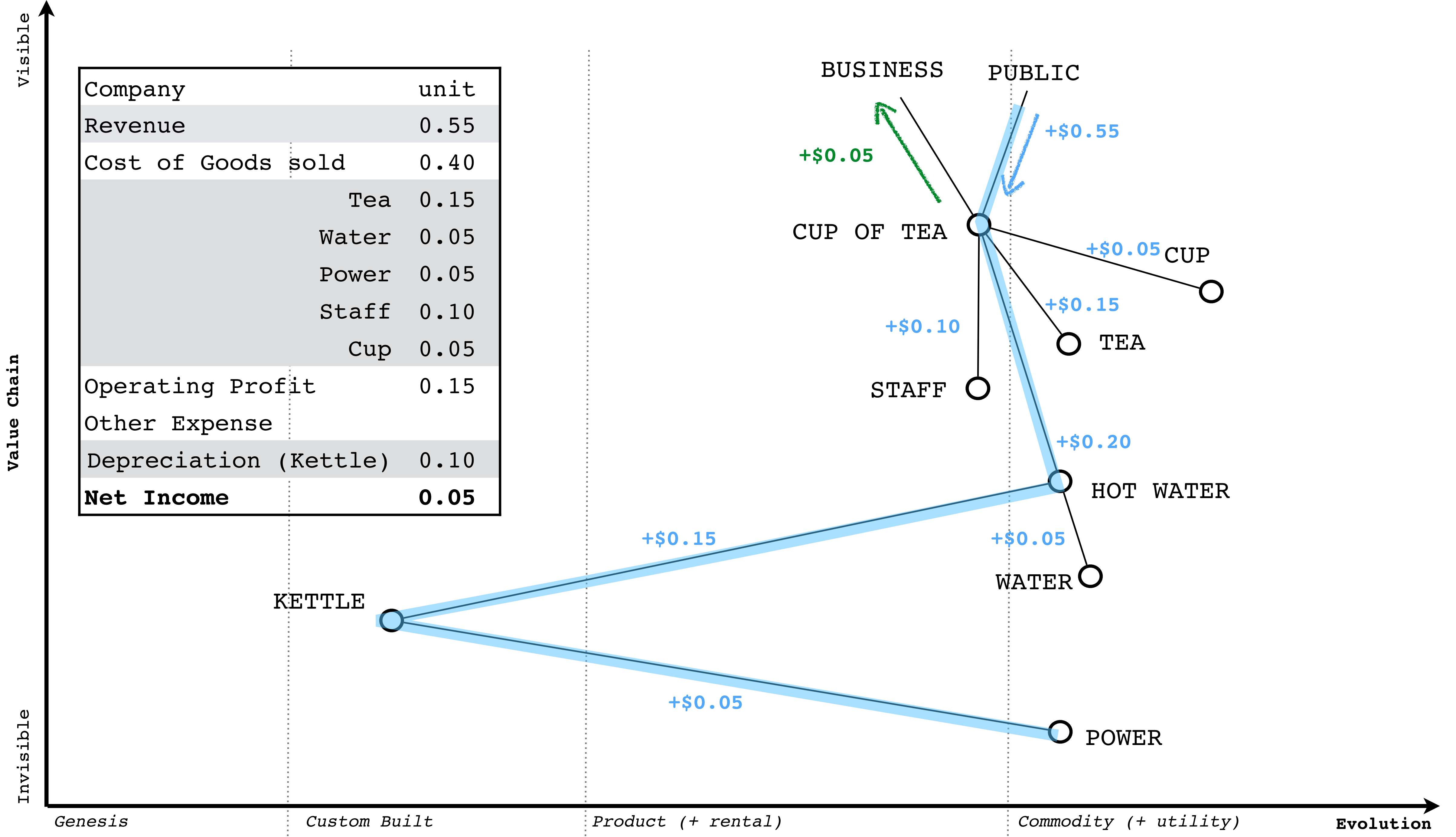

Company	unit
Revenue	0.55
Cost of Goods sold	0.40
Tea	0.15
Water	0.05
Power	0.05
Staff	0.10
Cup	0.05
Operating Profit	0.15
Other Expense	
Depreciation (Kettle)	0.10
Net Income	0.05

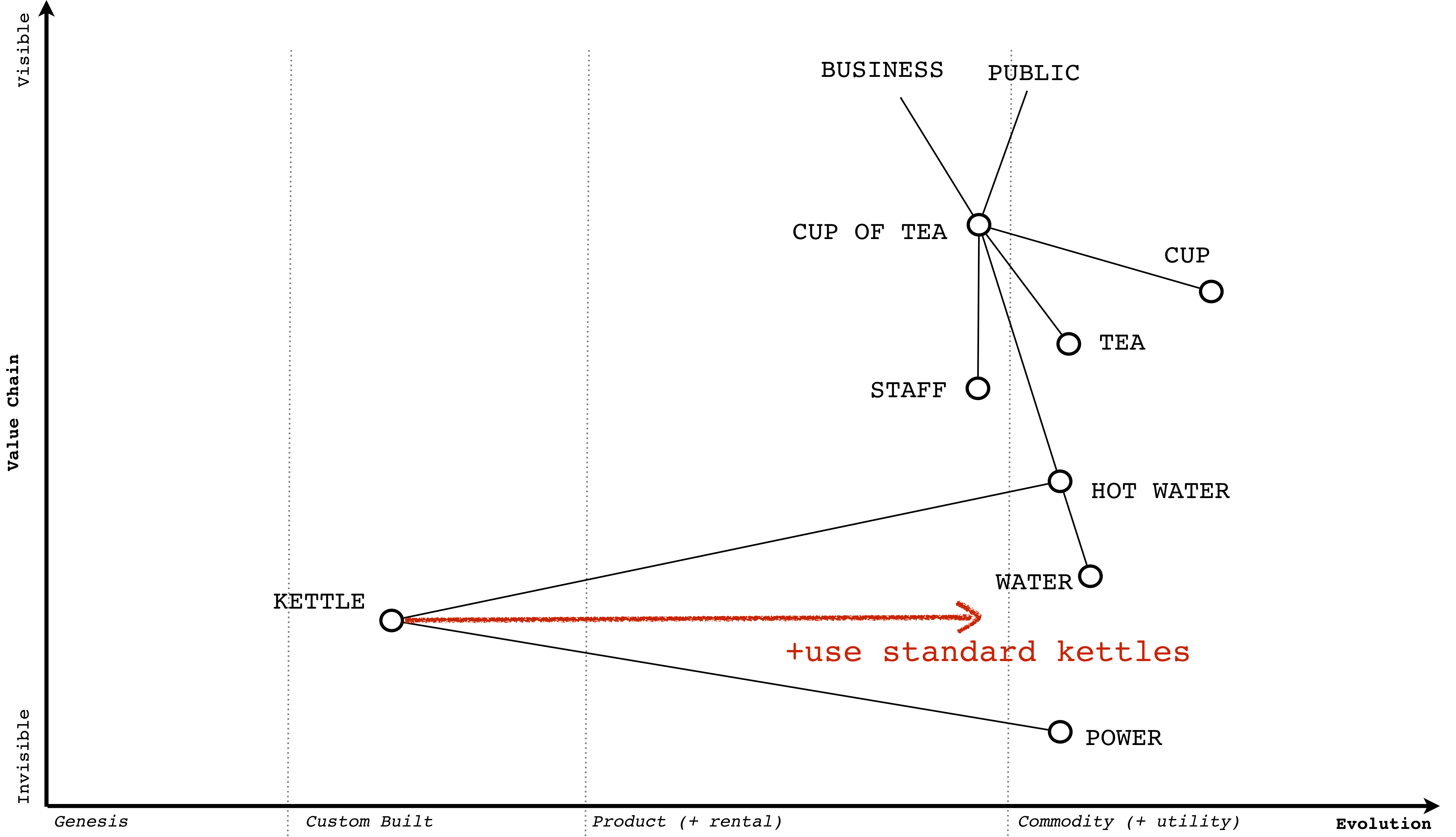

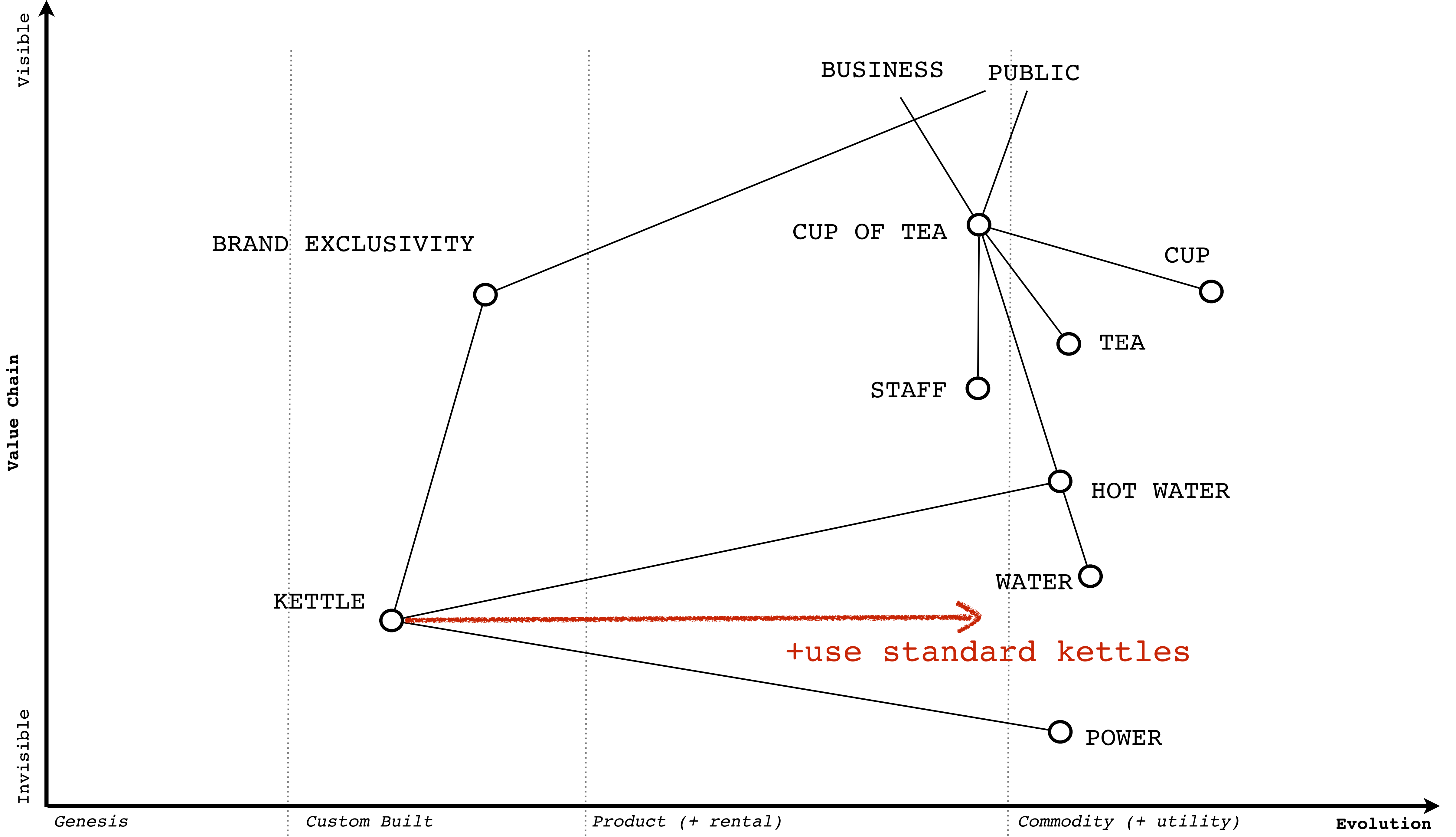

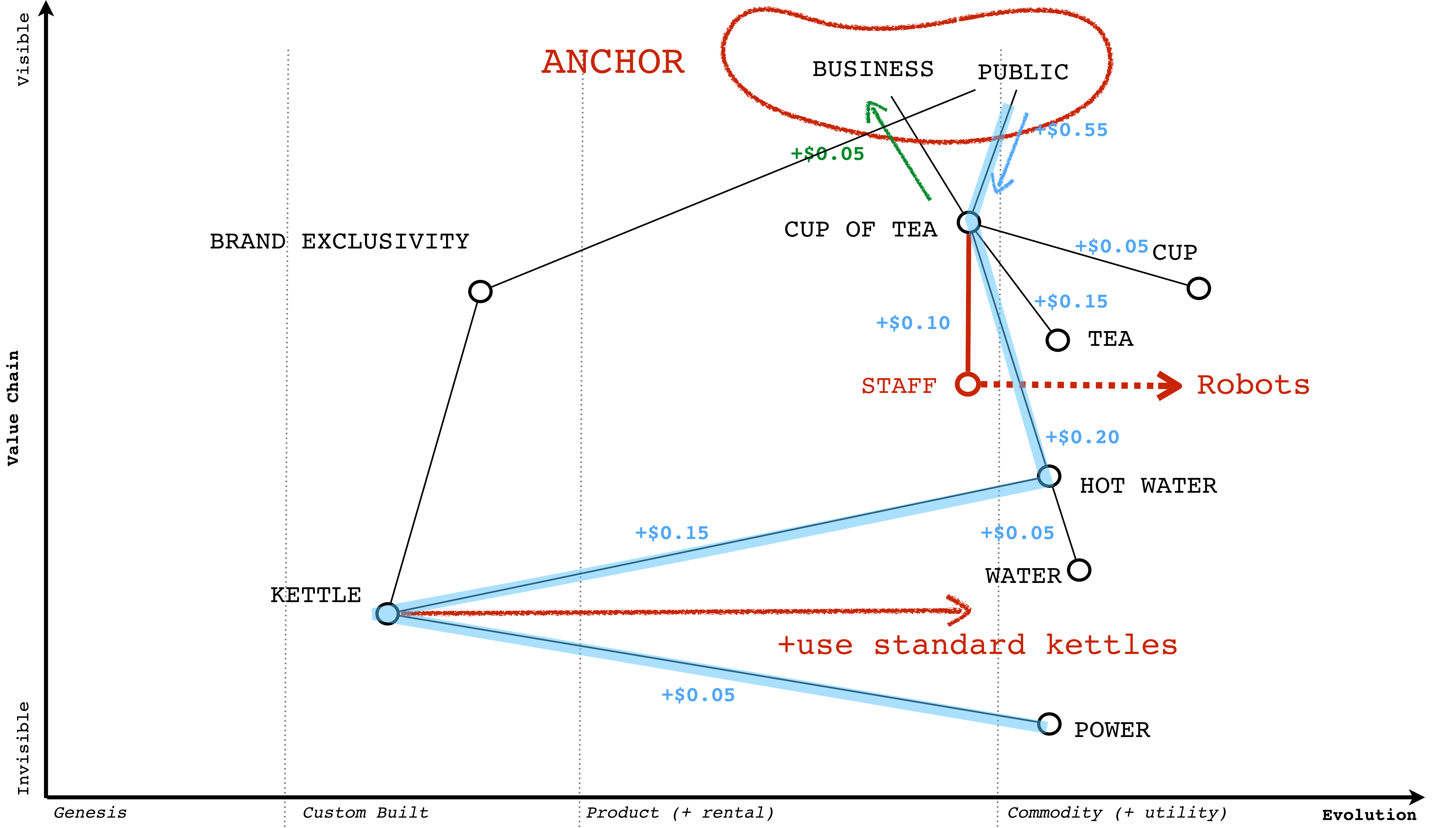



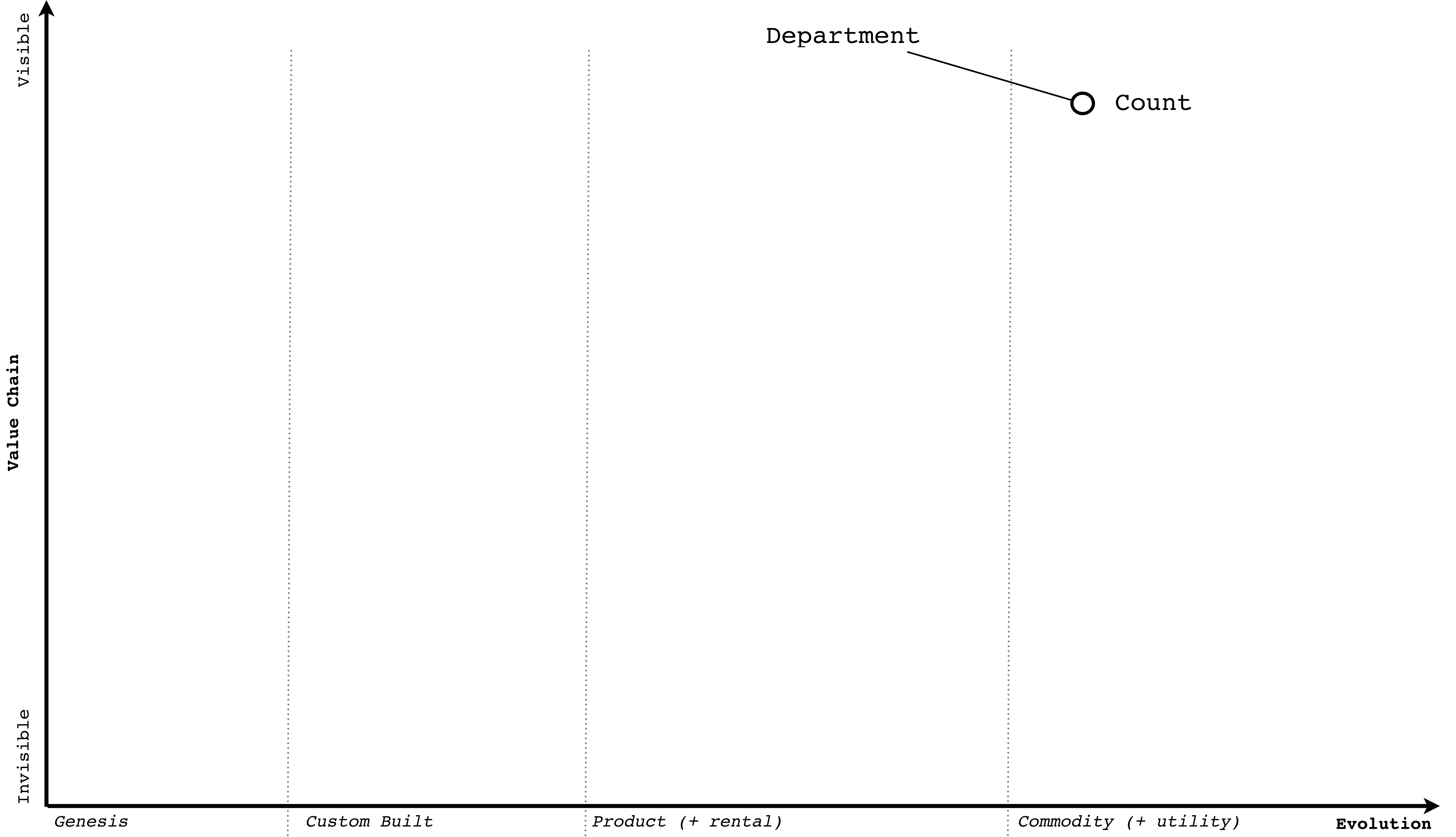

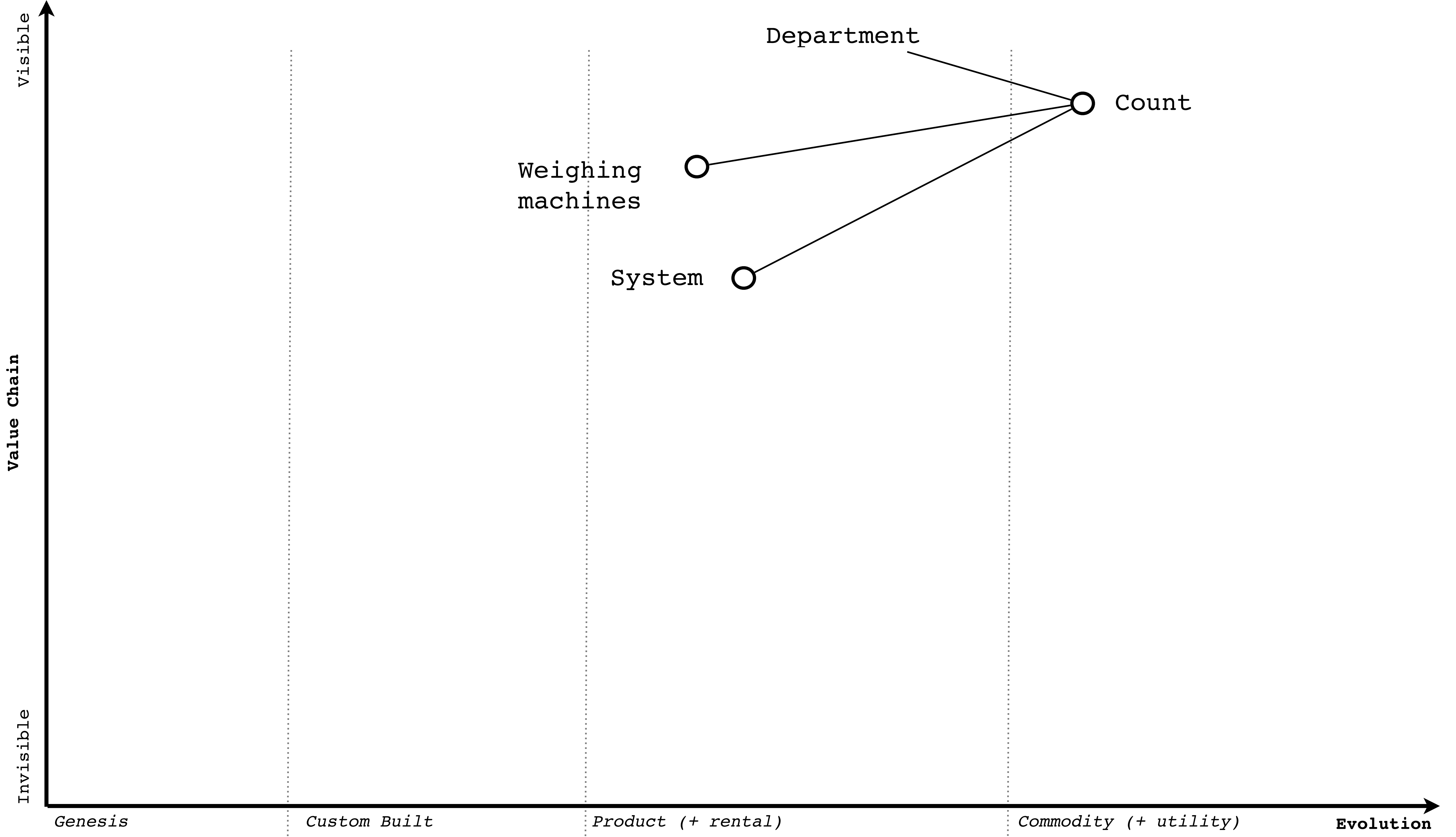

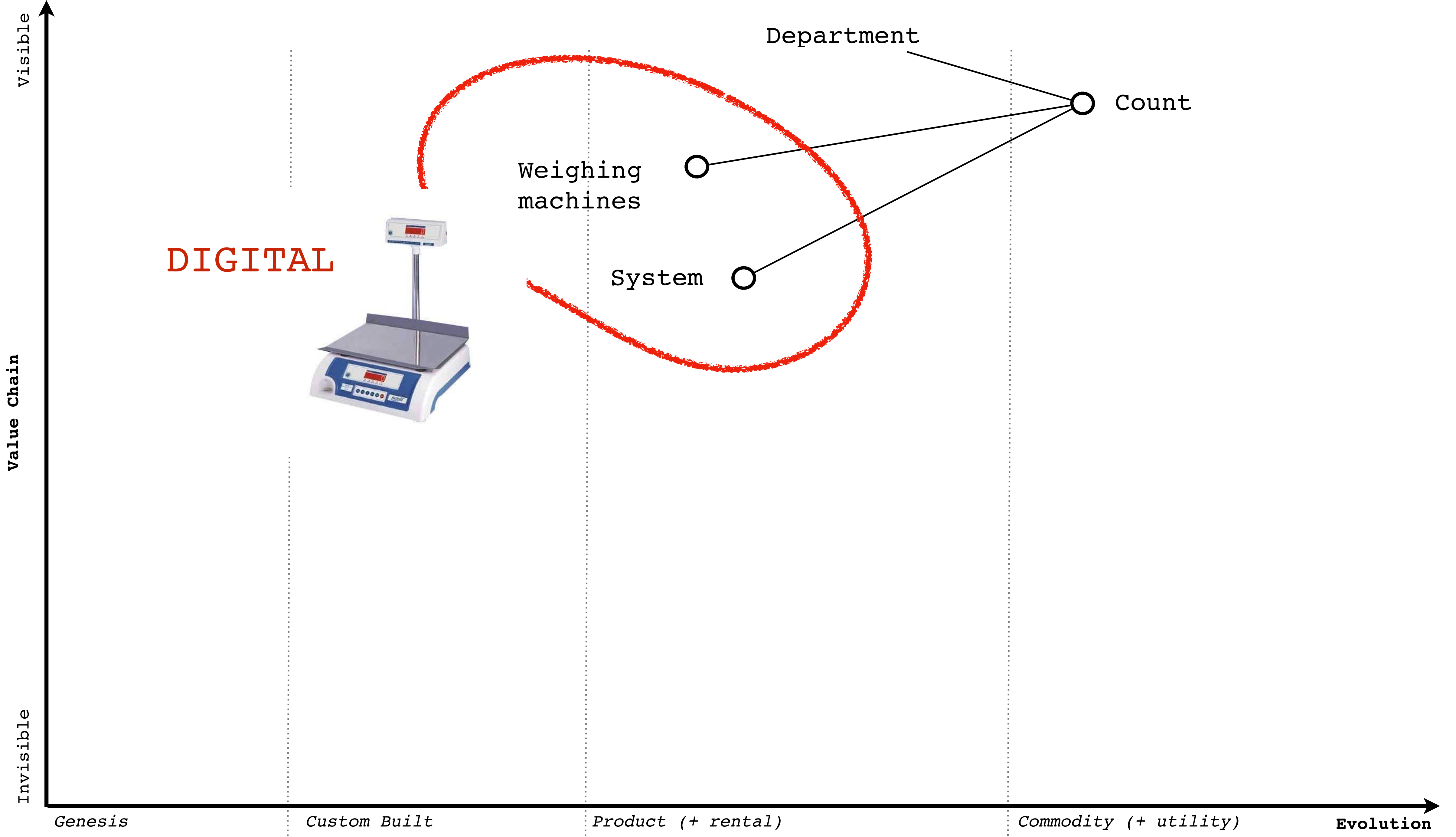

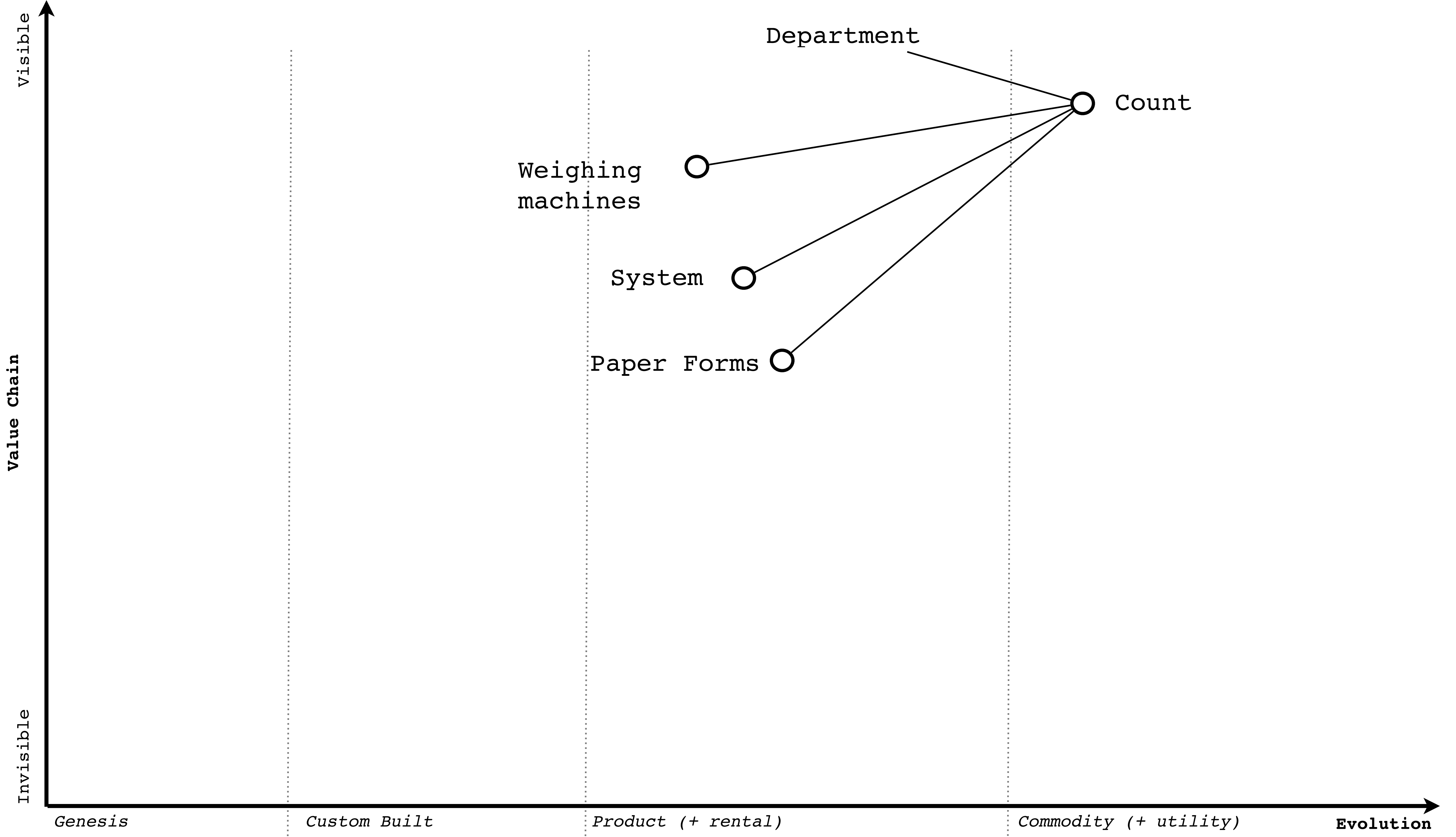

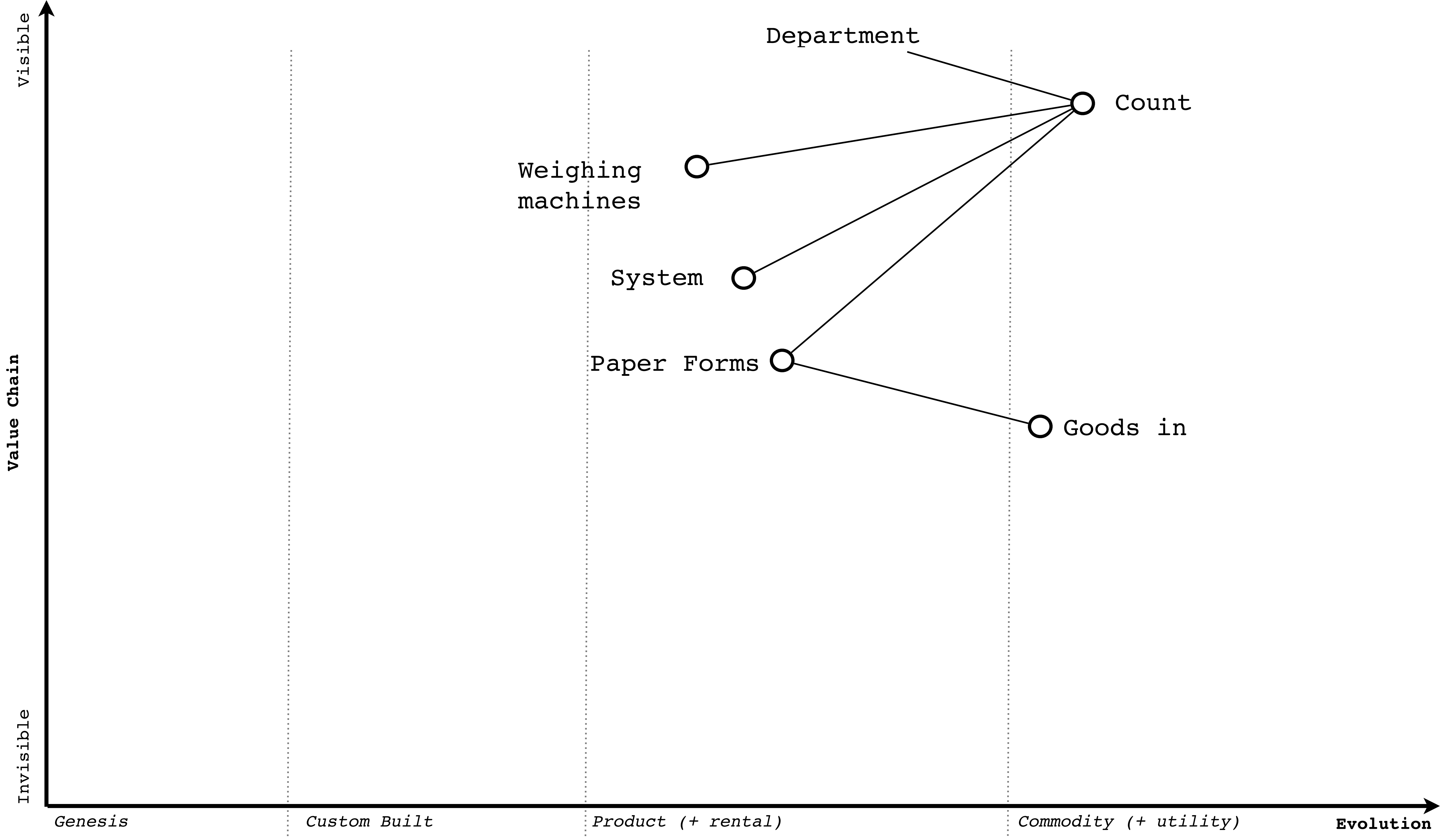

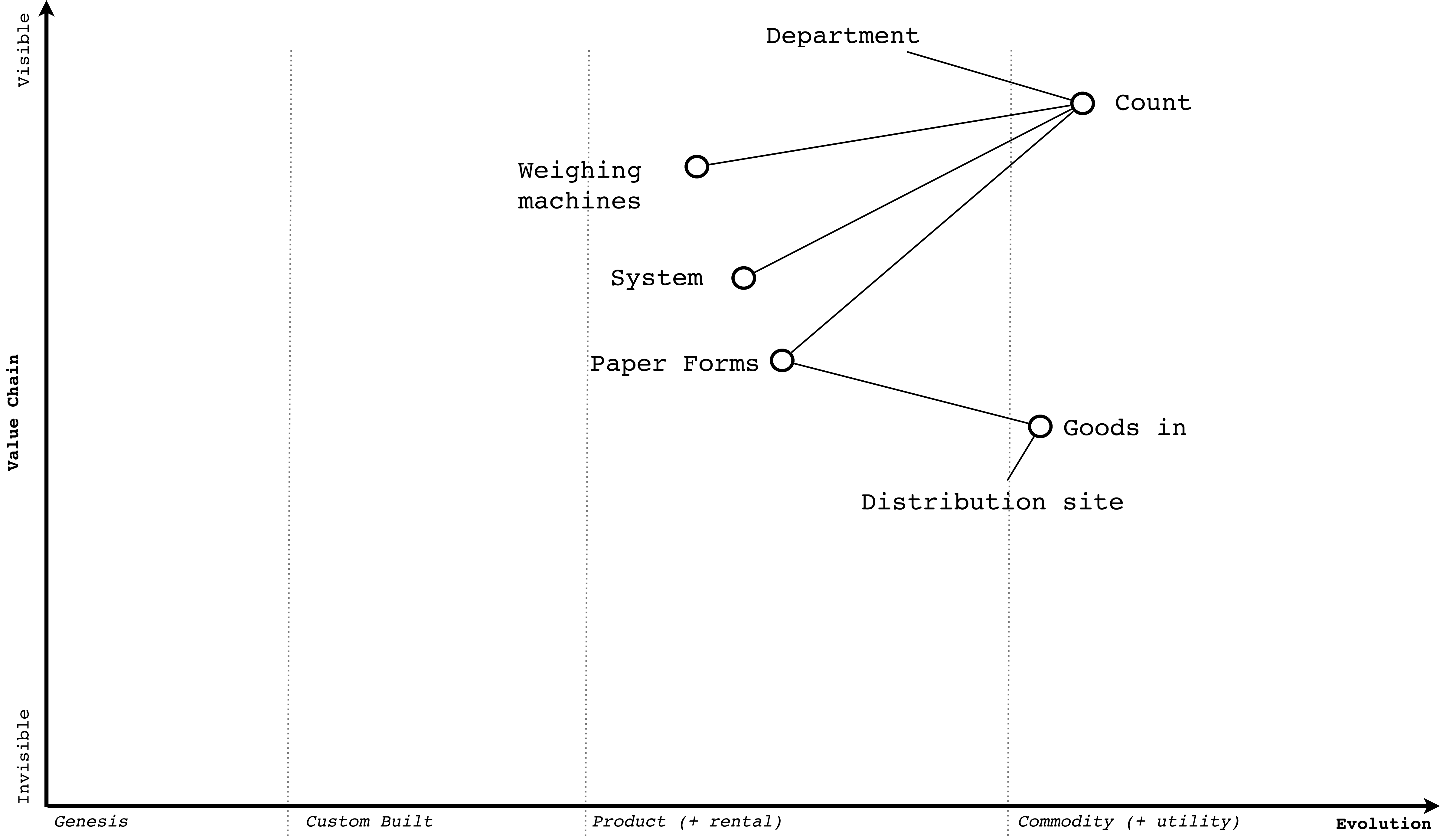

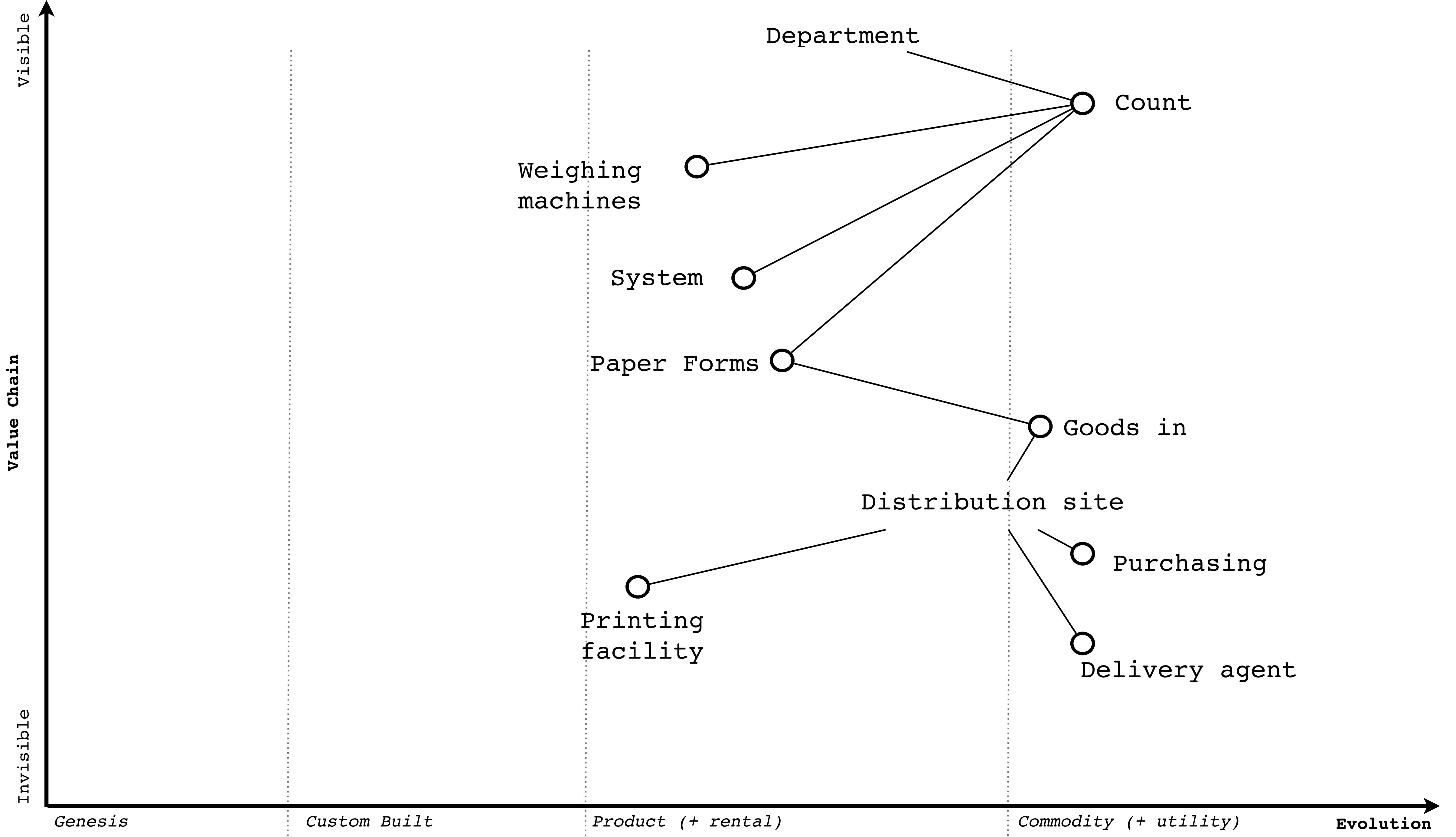

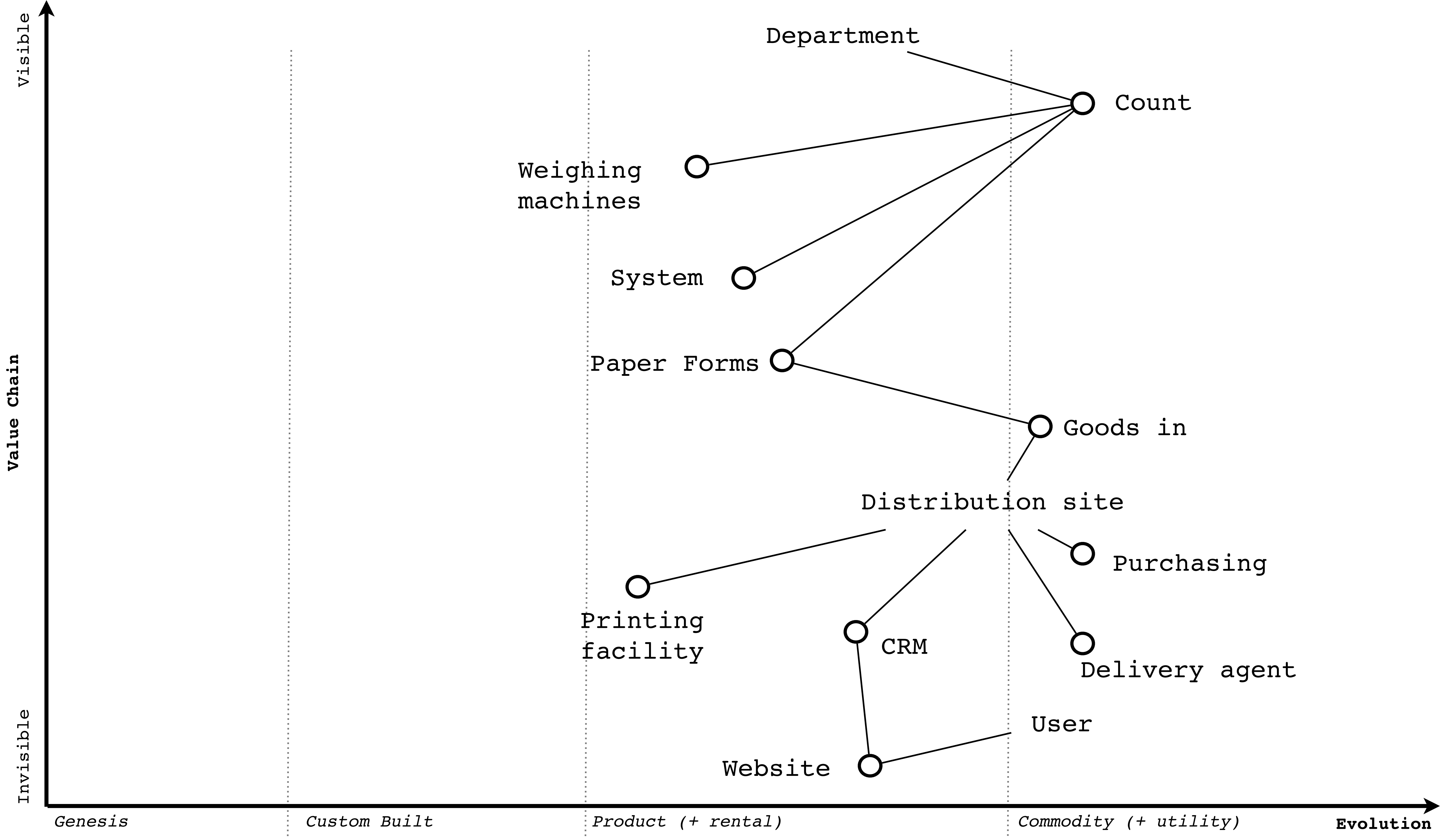

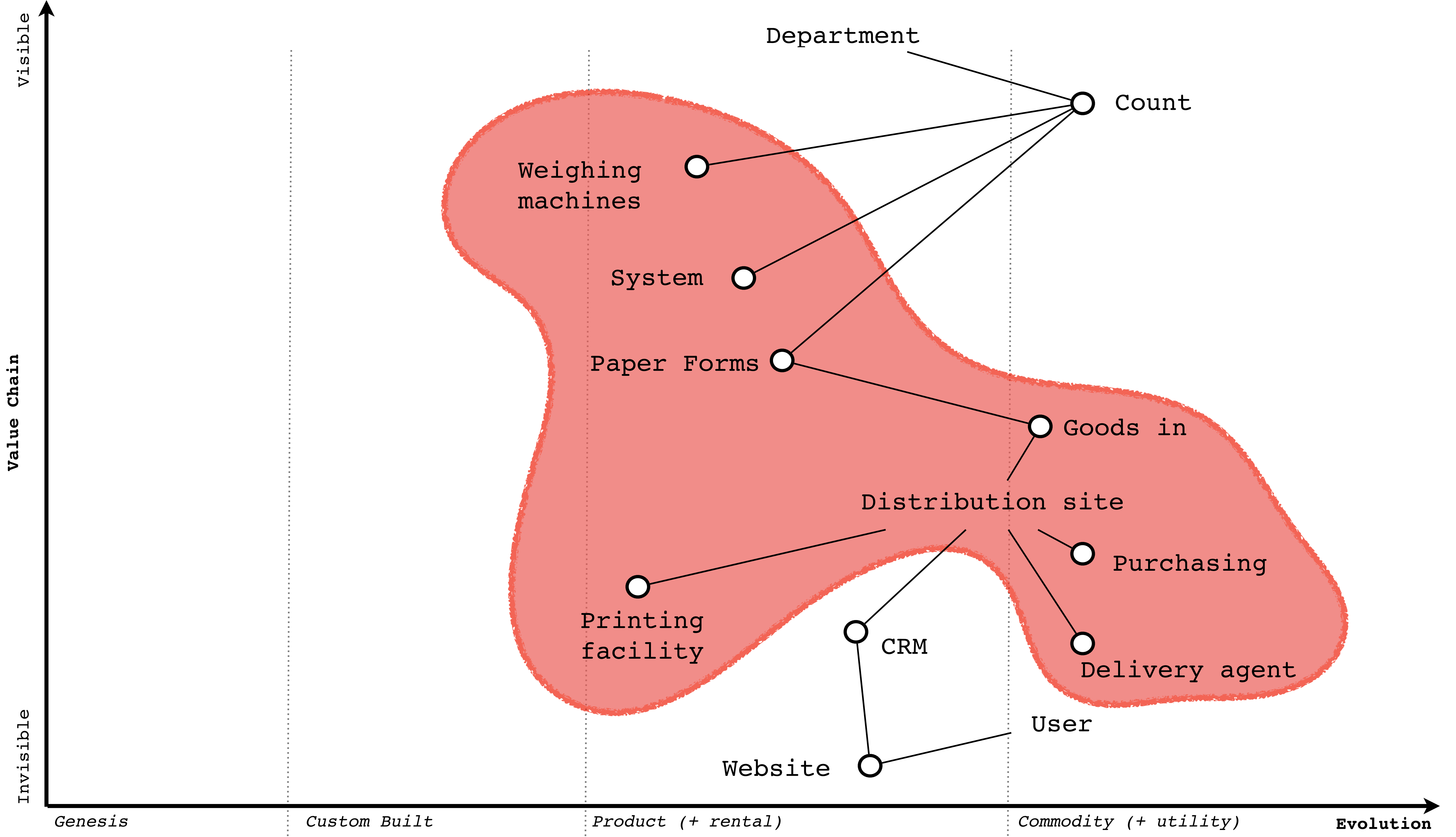

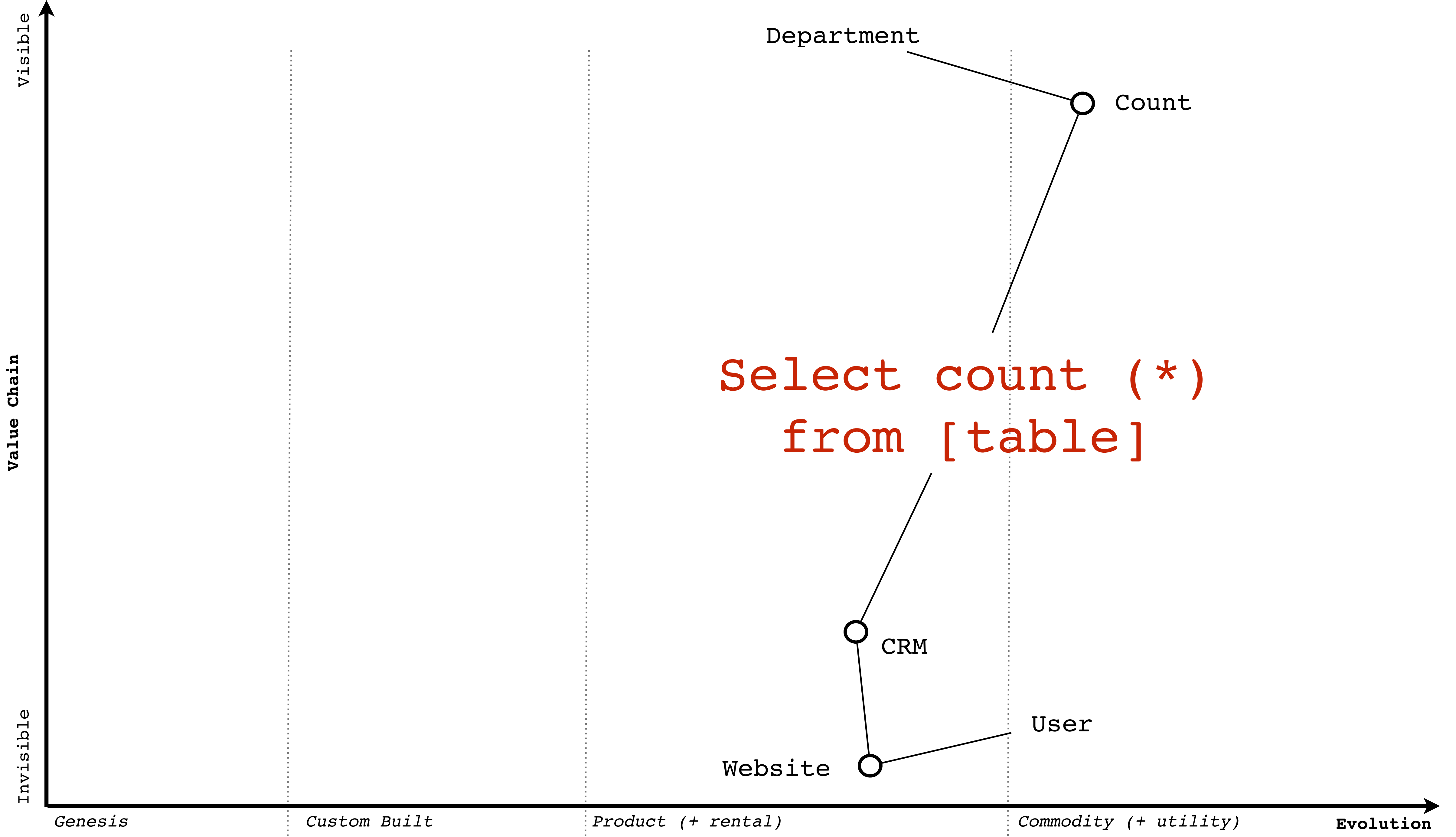

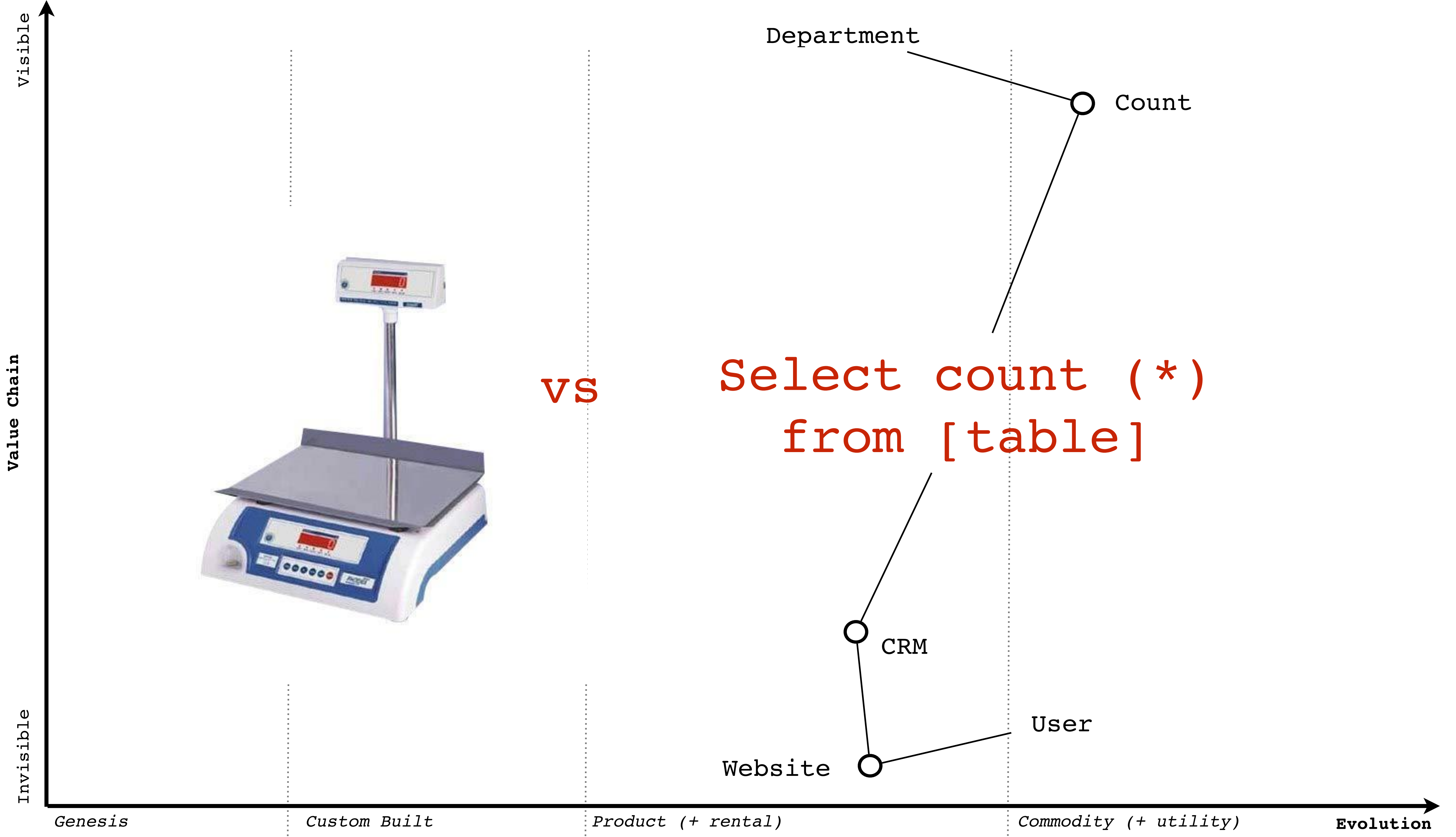

Strategy



Maps

Communication



Patterns

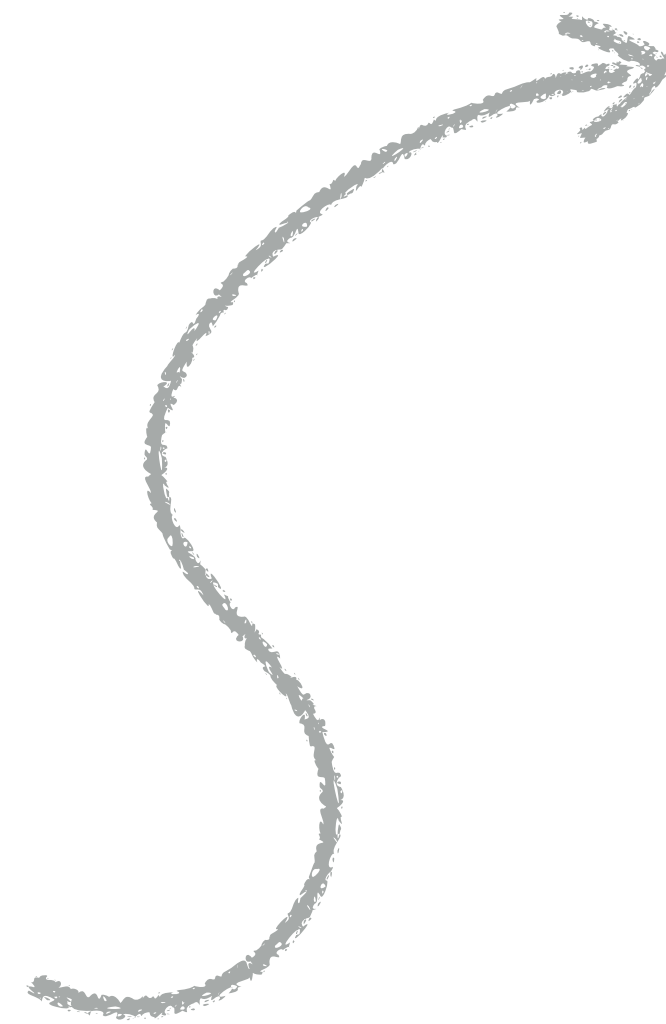

Anticipation



Organisation



Leadership

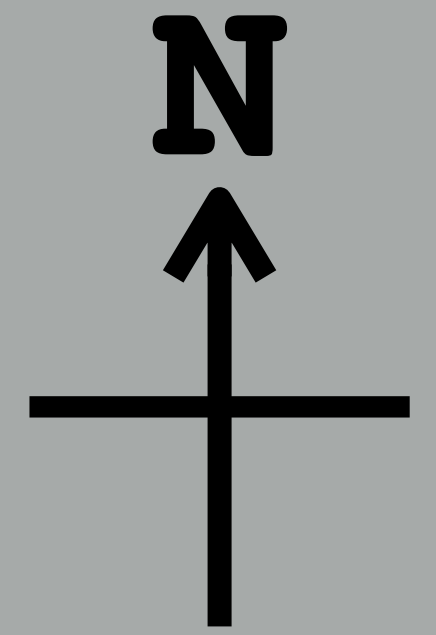

SERVERLESS

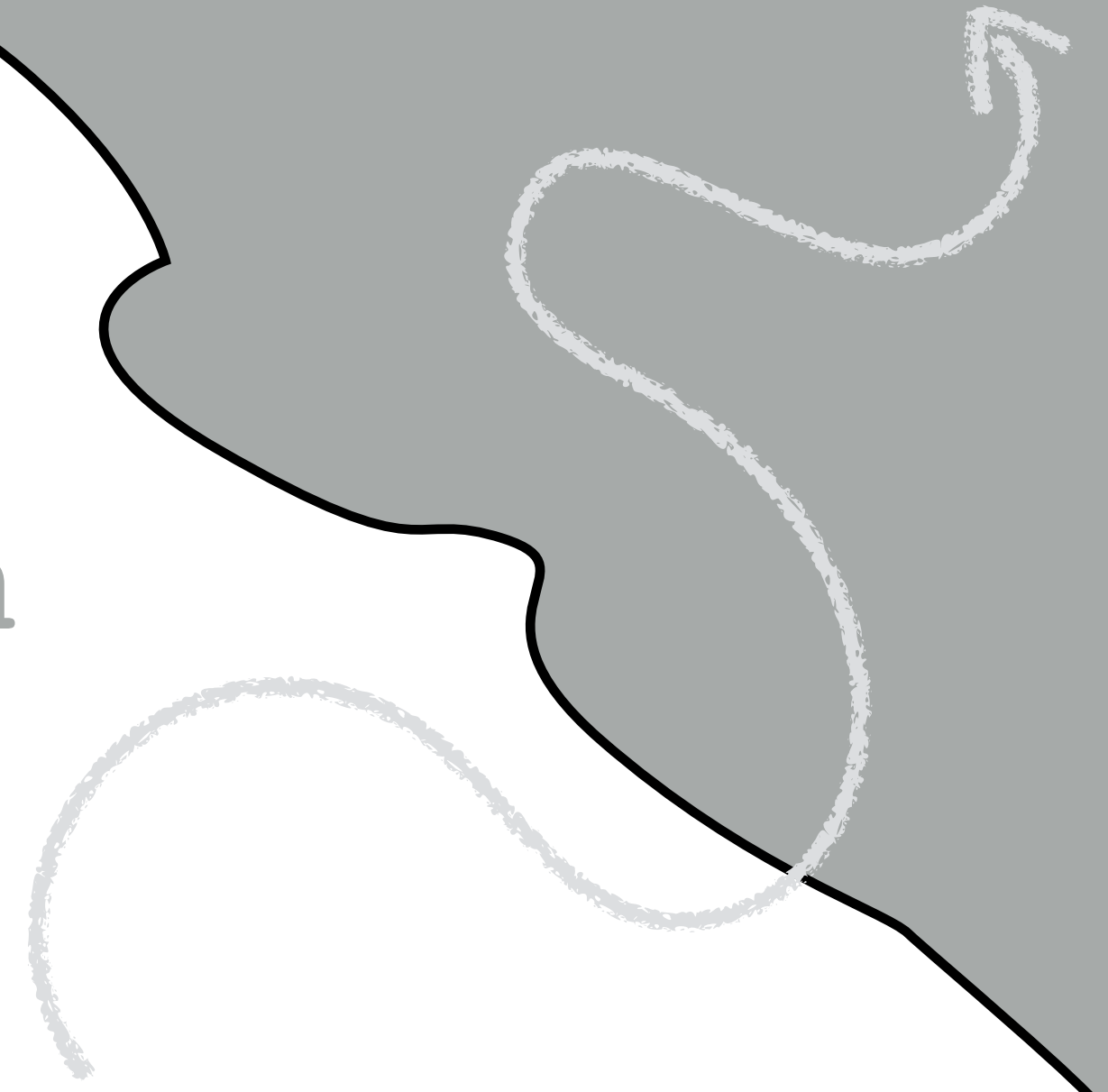

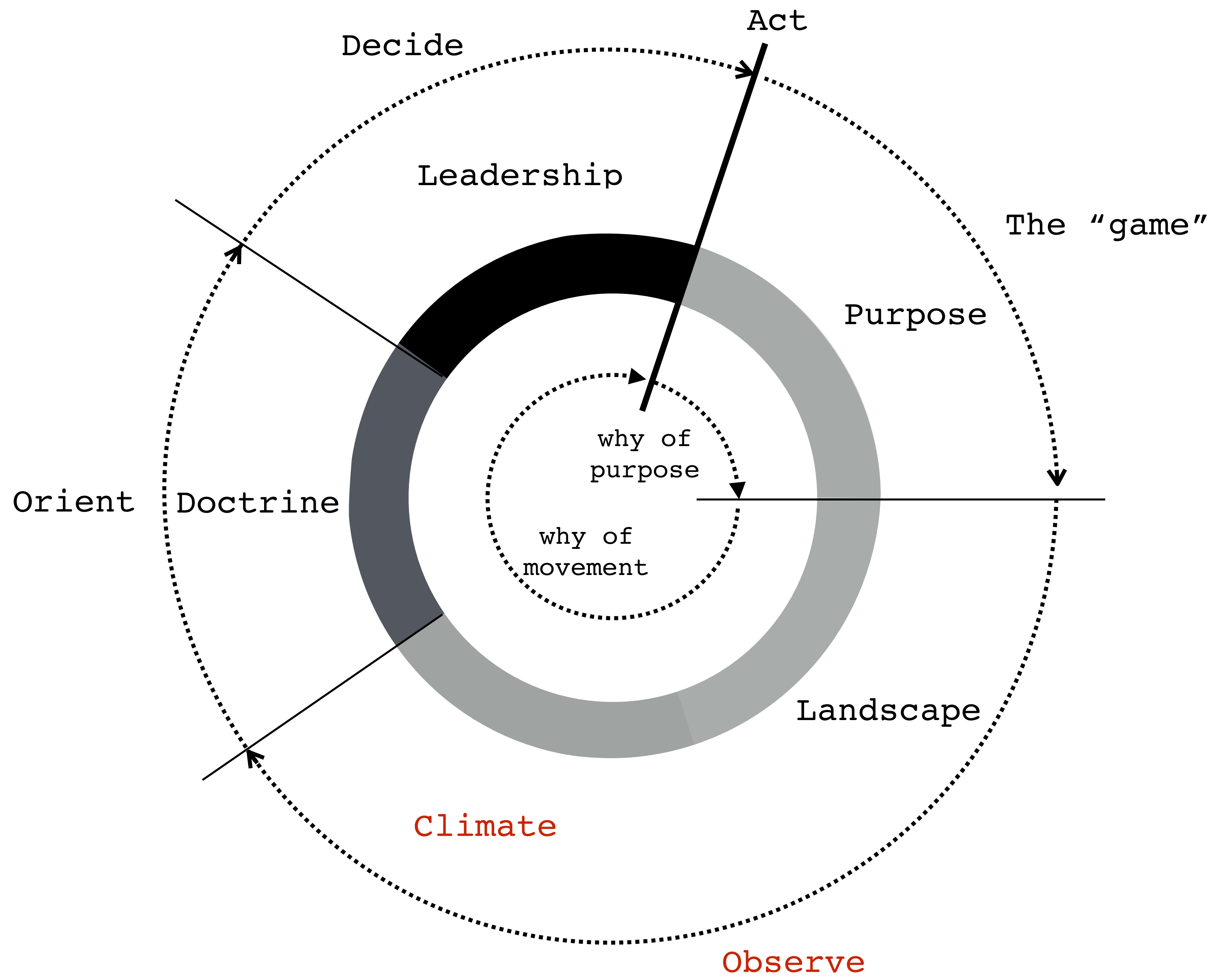

Climate

Rules that influence
the game

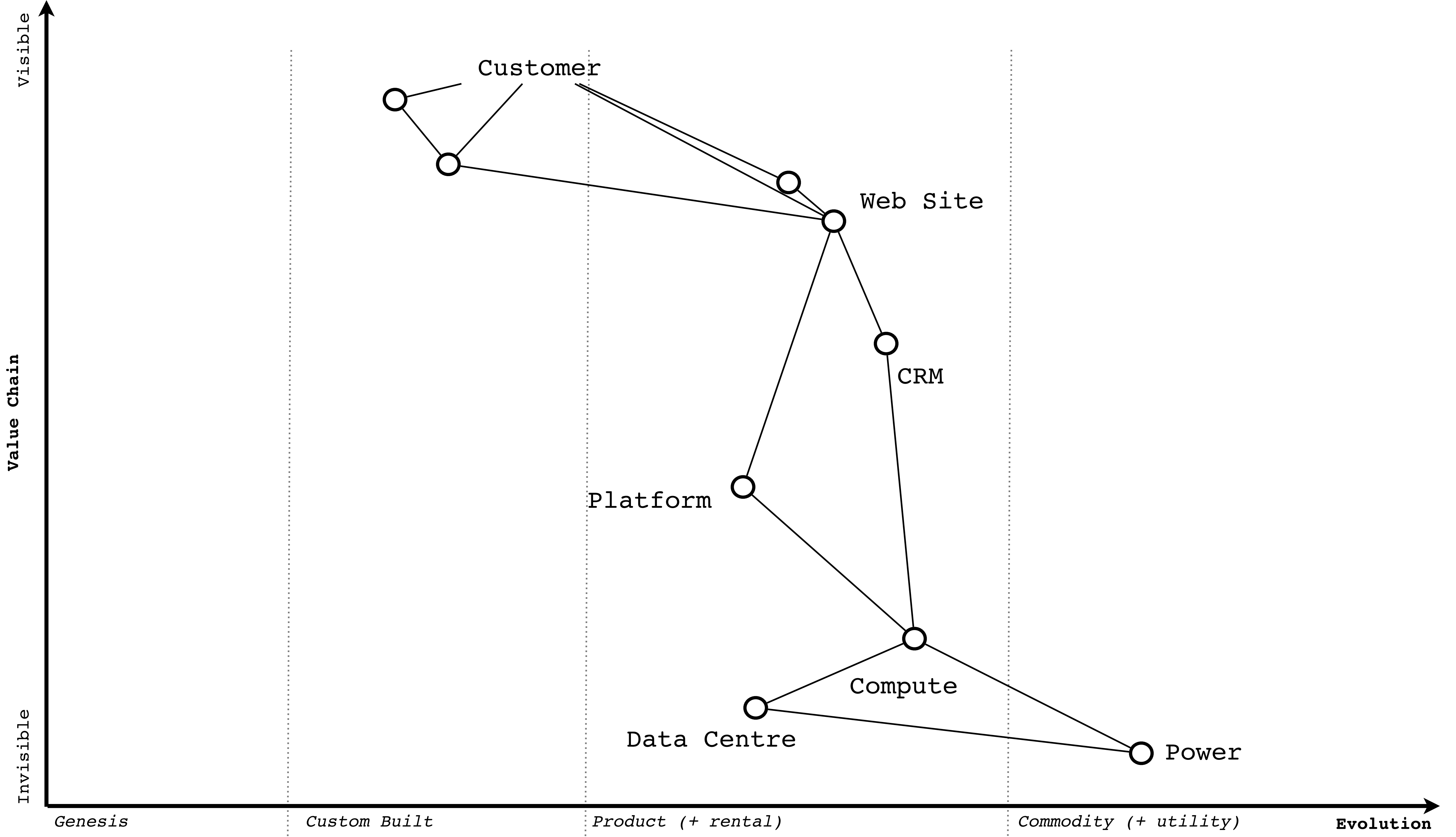

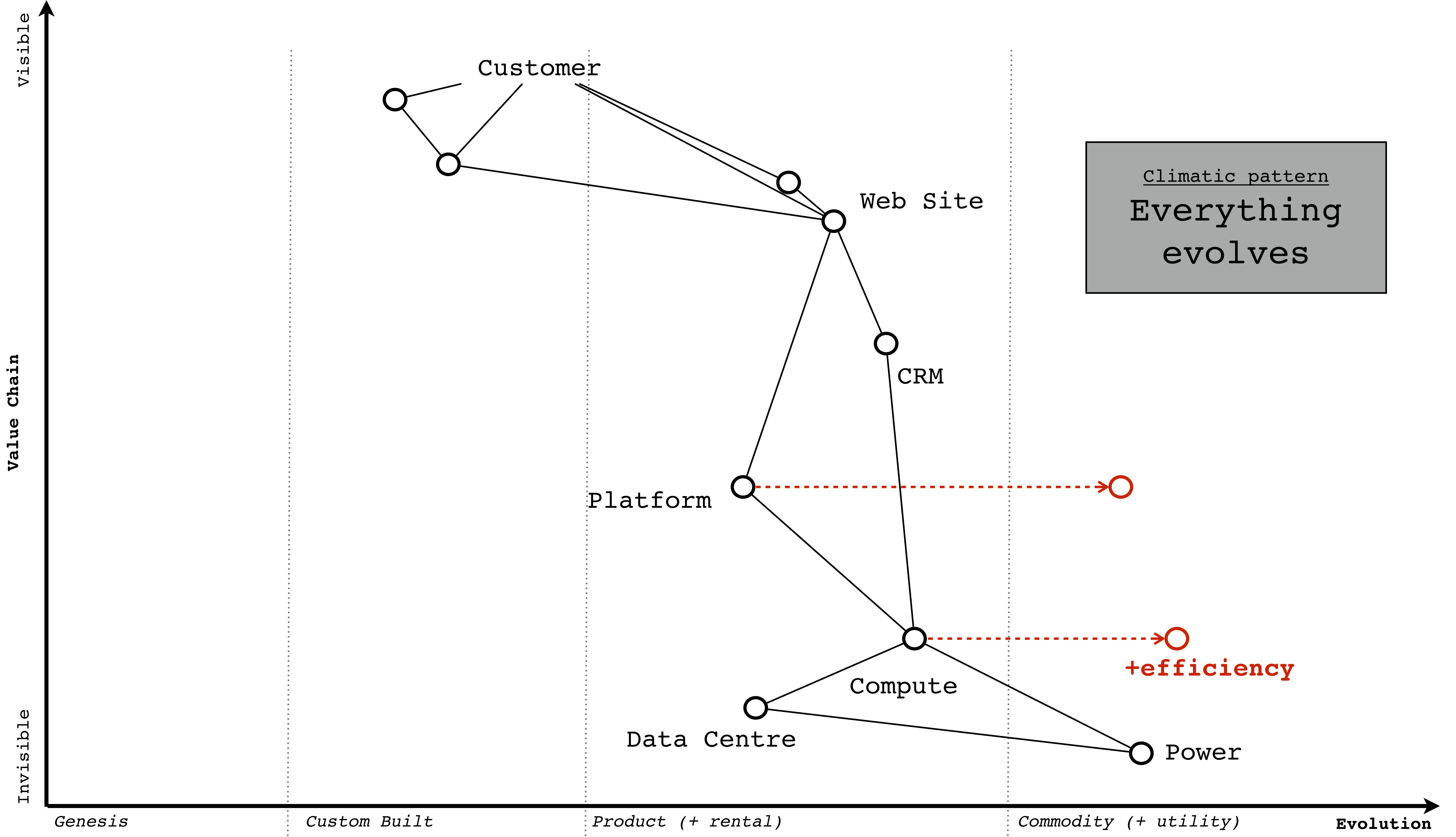

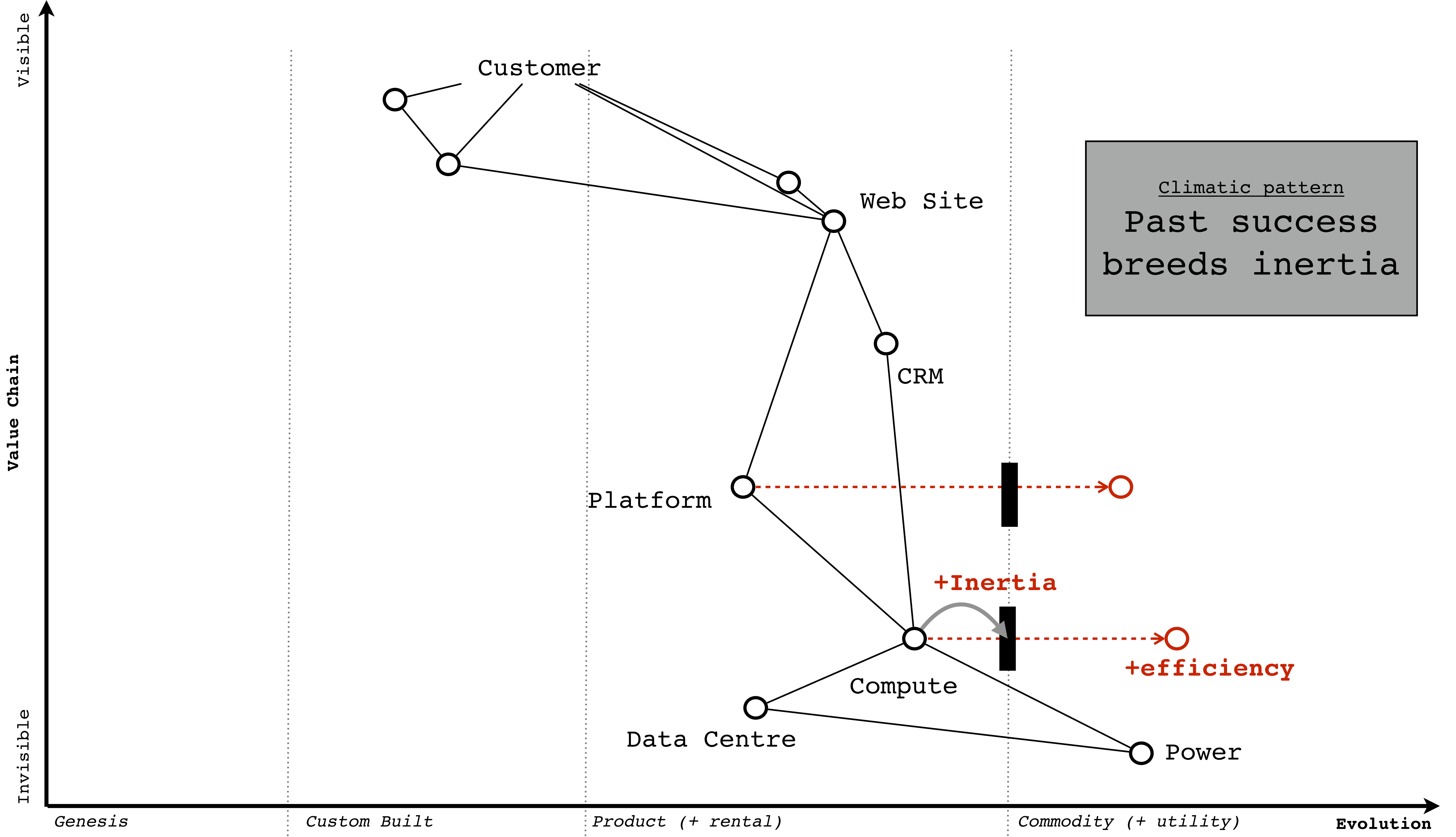



BLOCKBUSTER



NETFLIX®

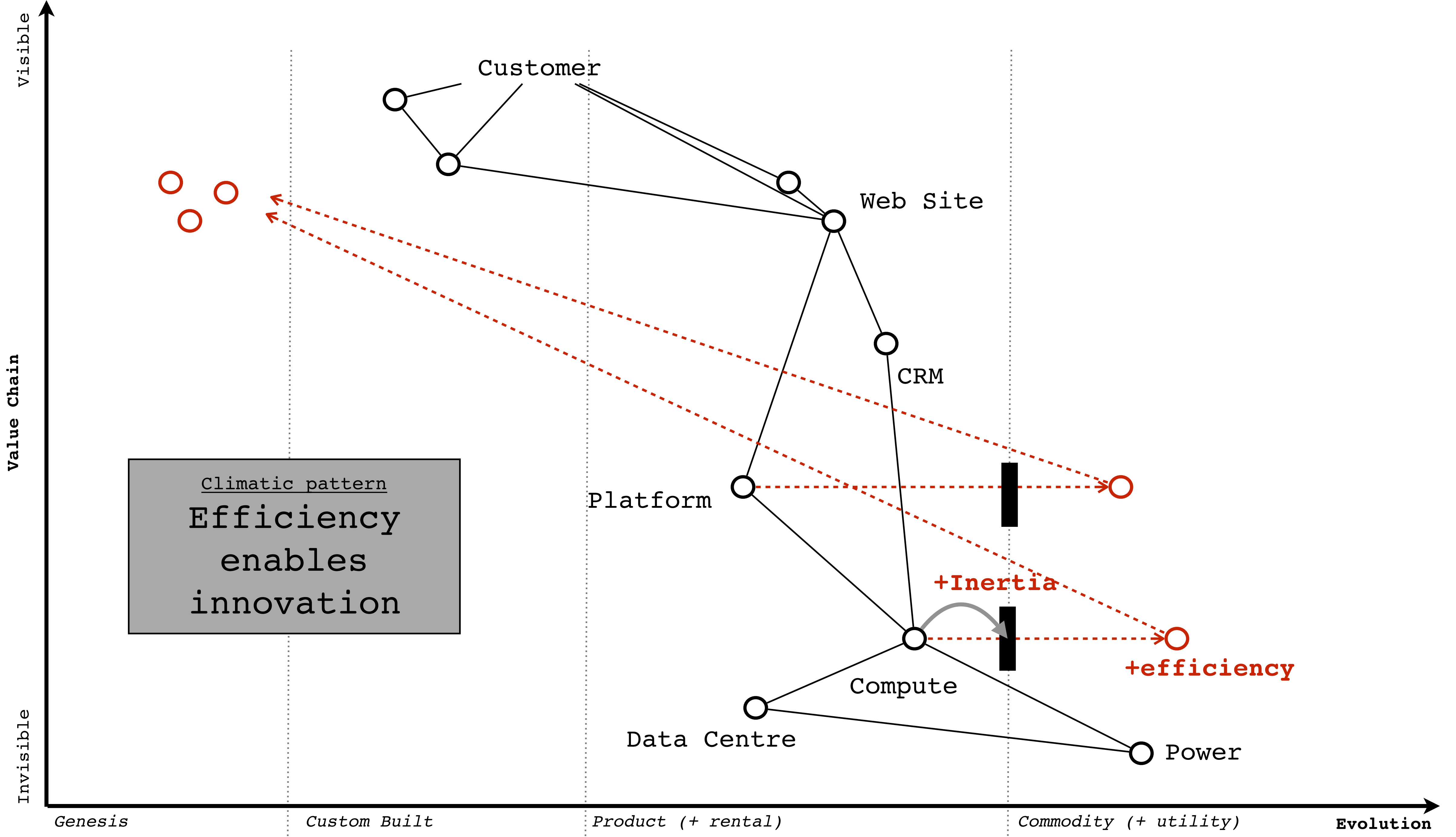

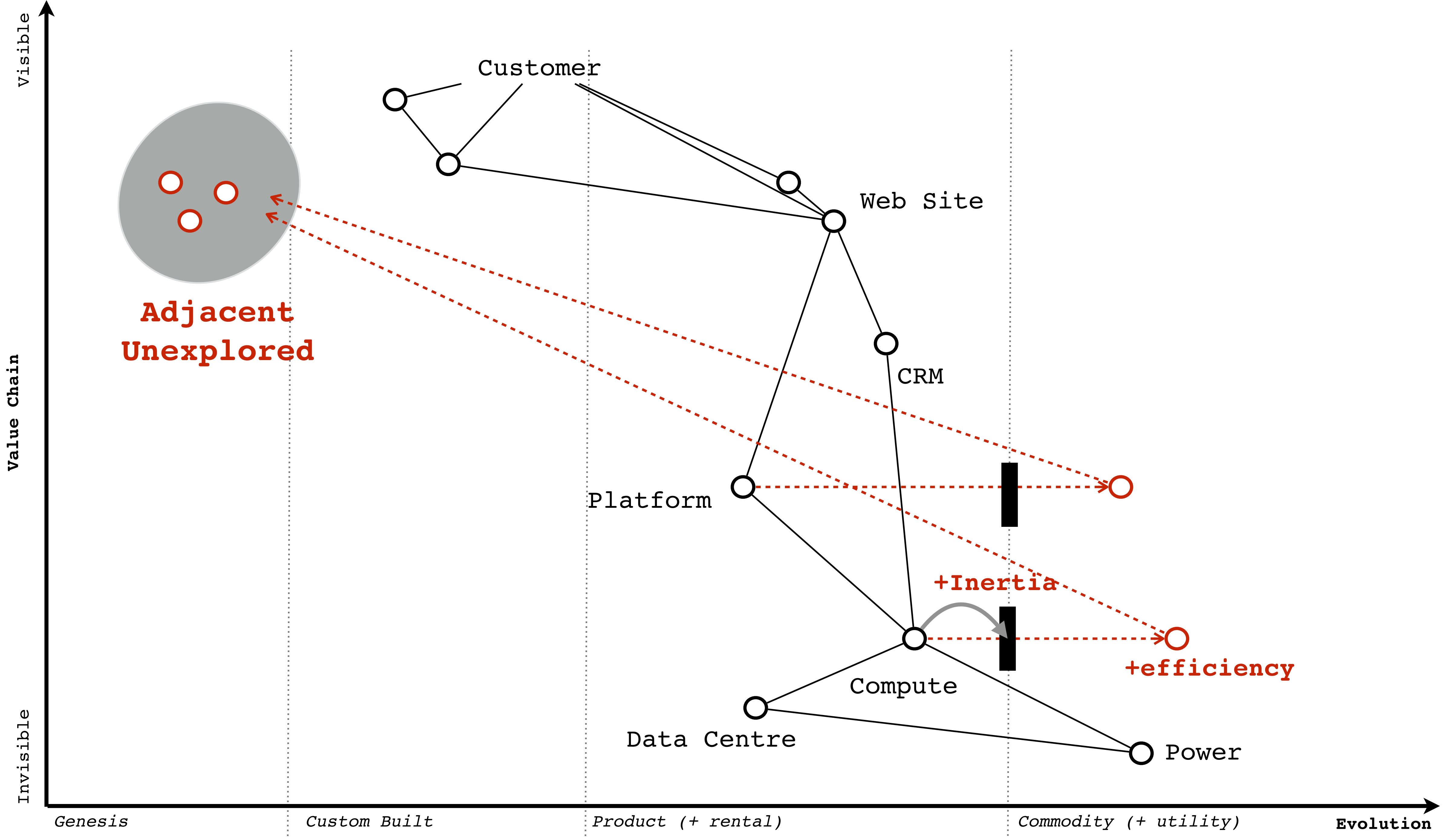

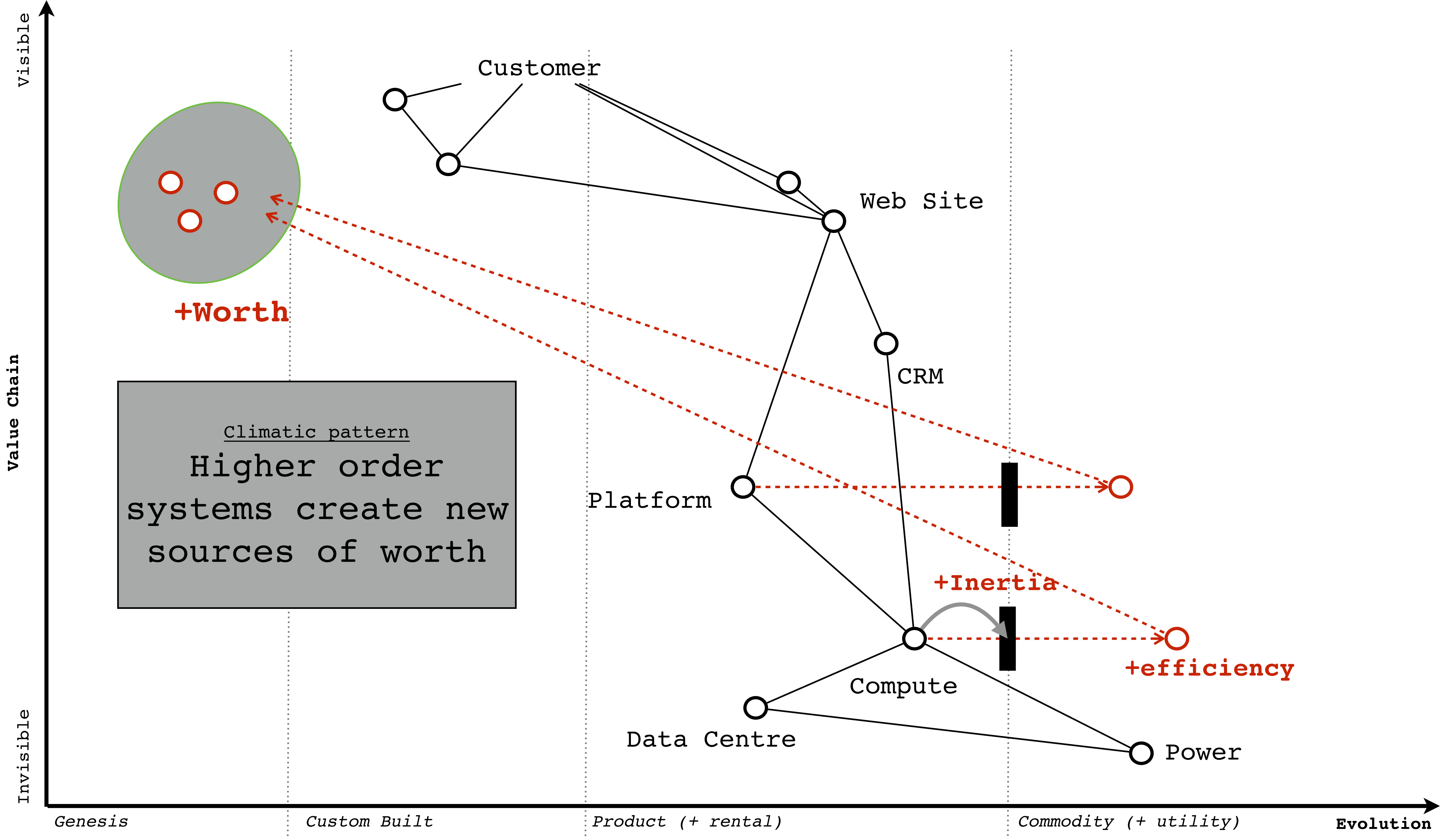

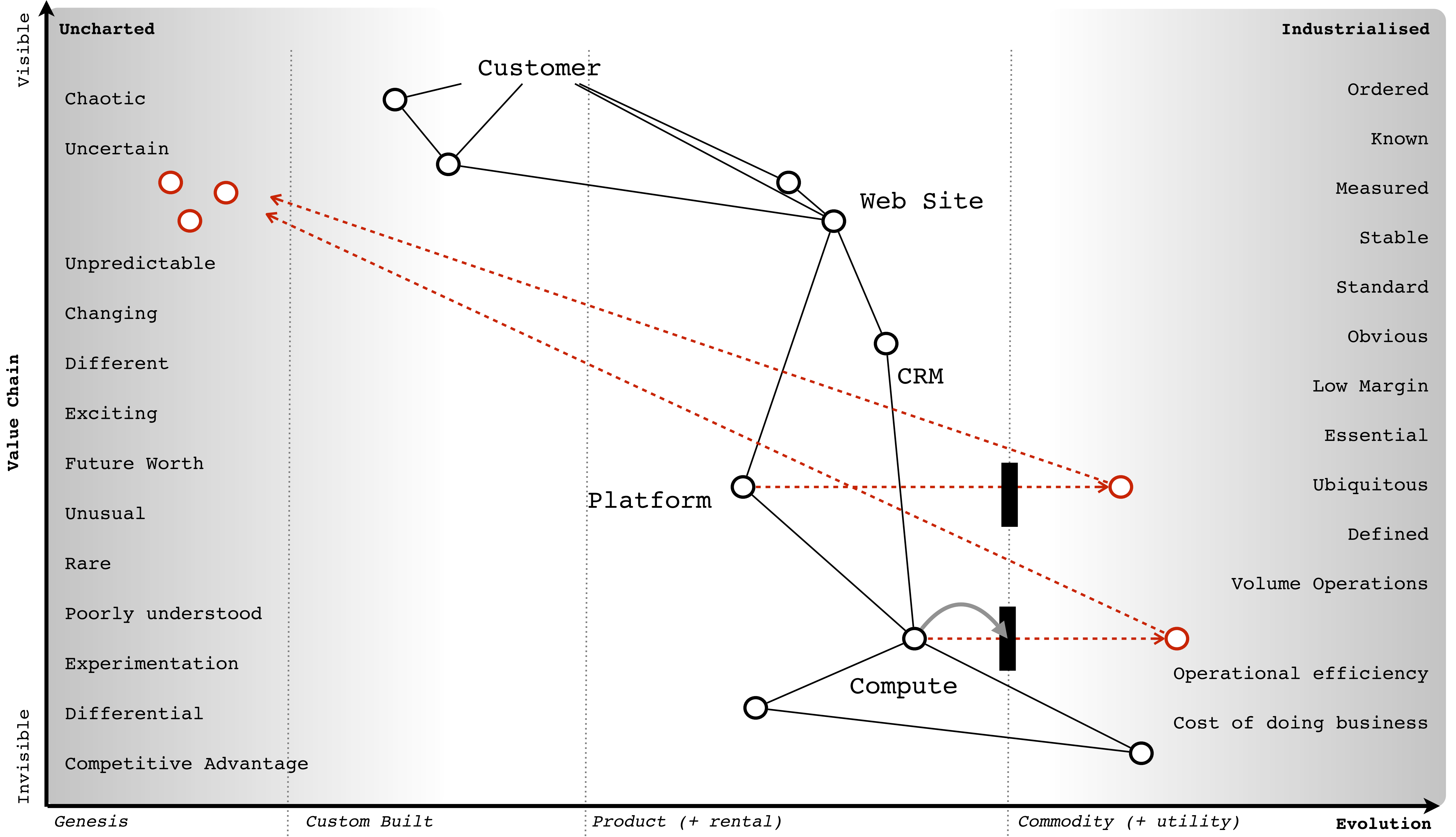

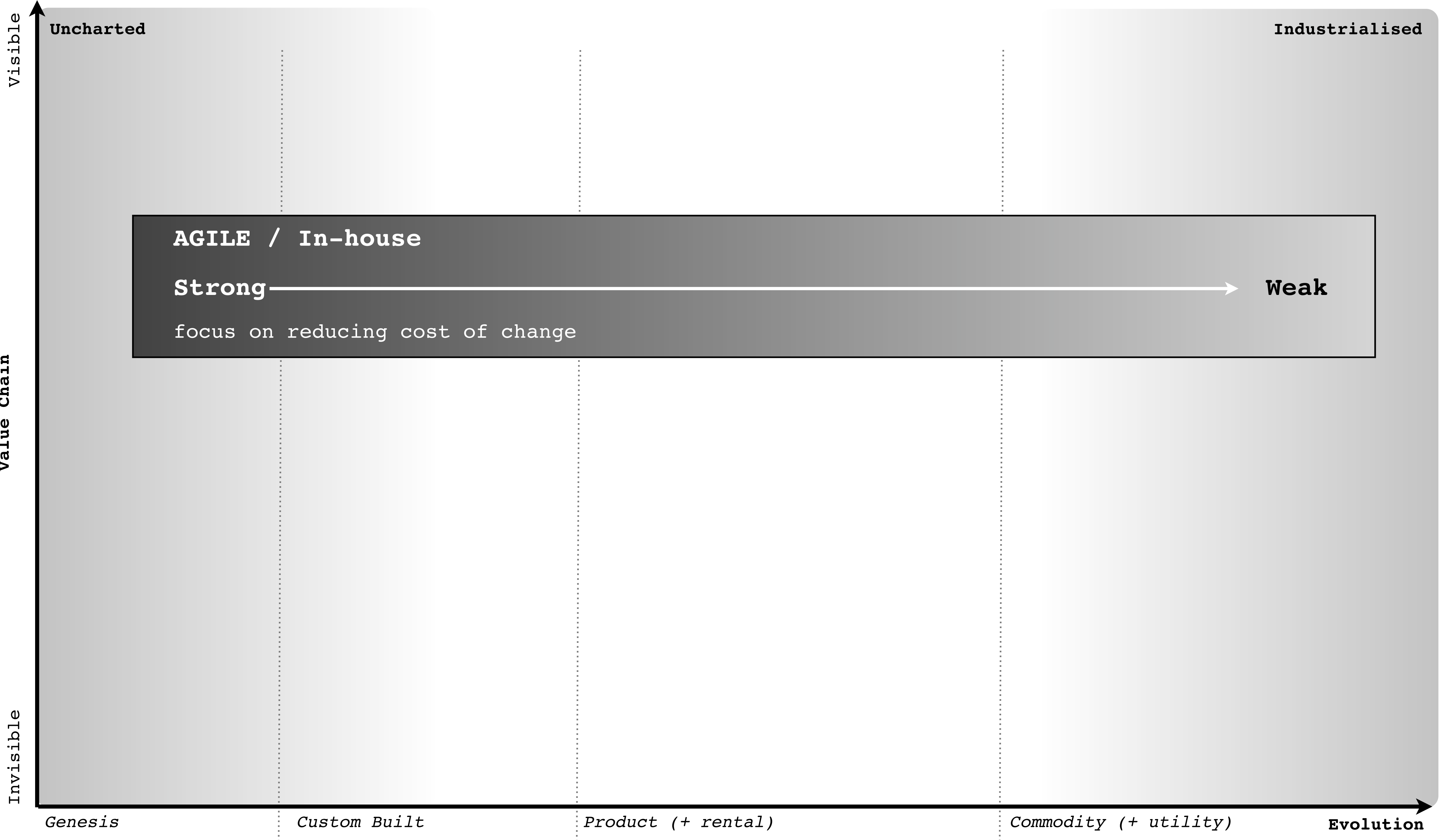

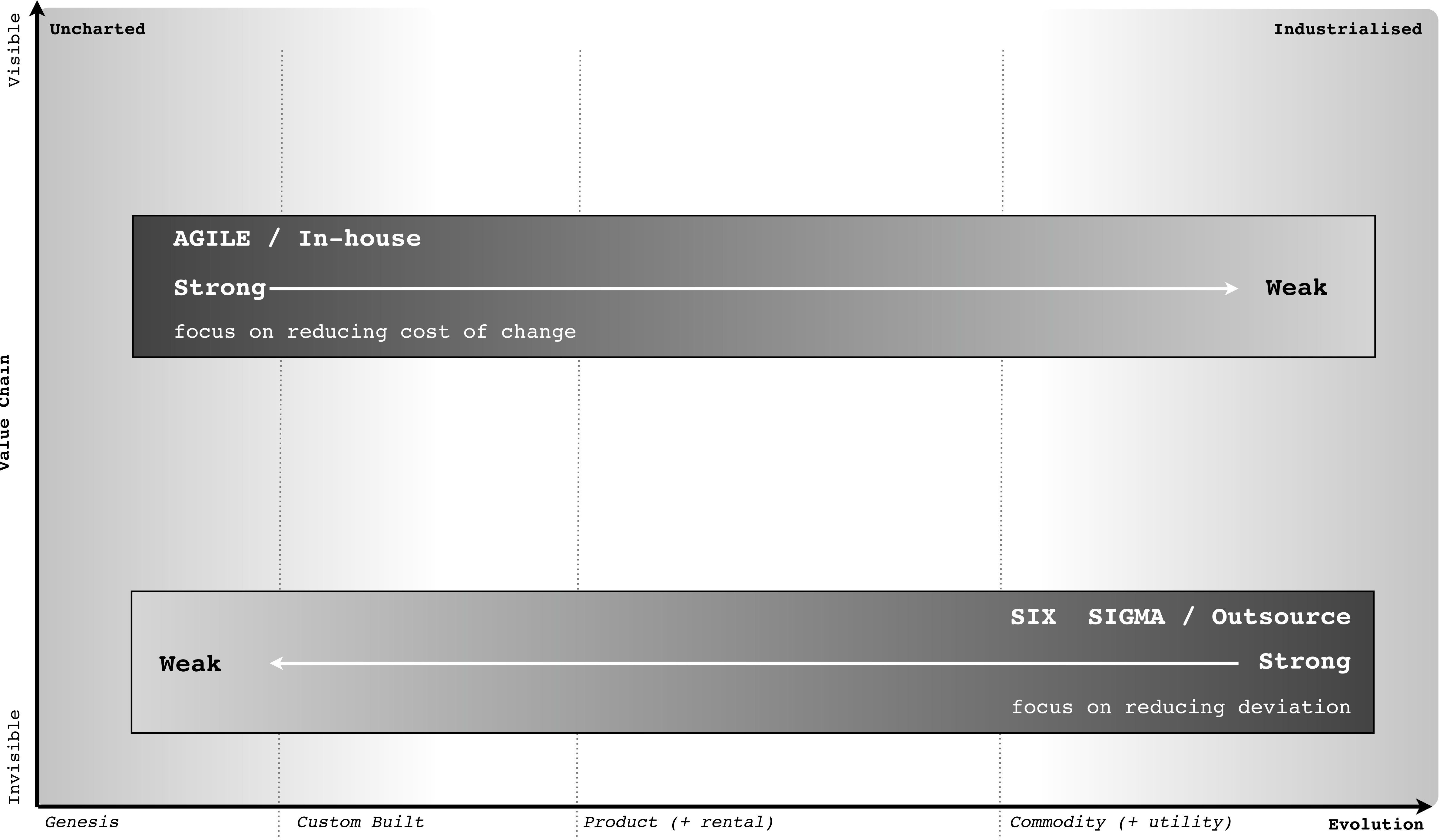

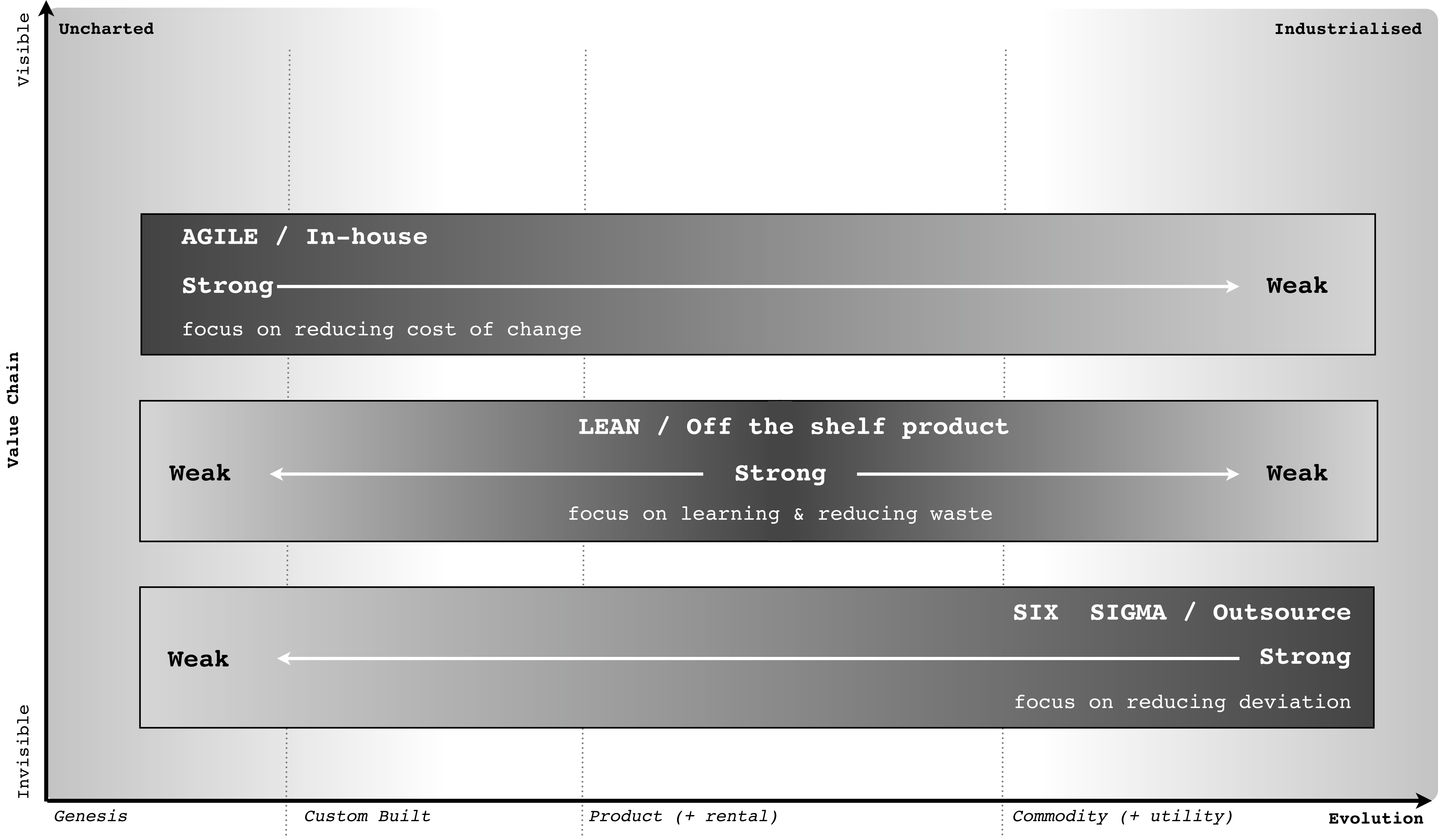

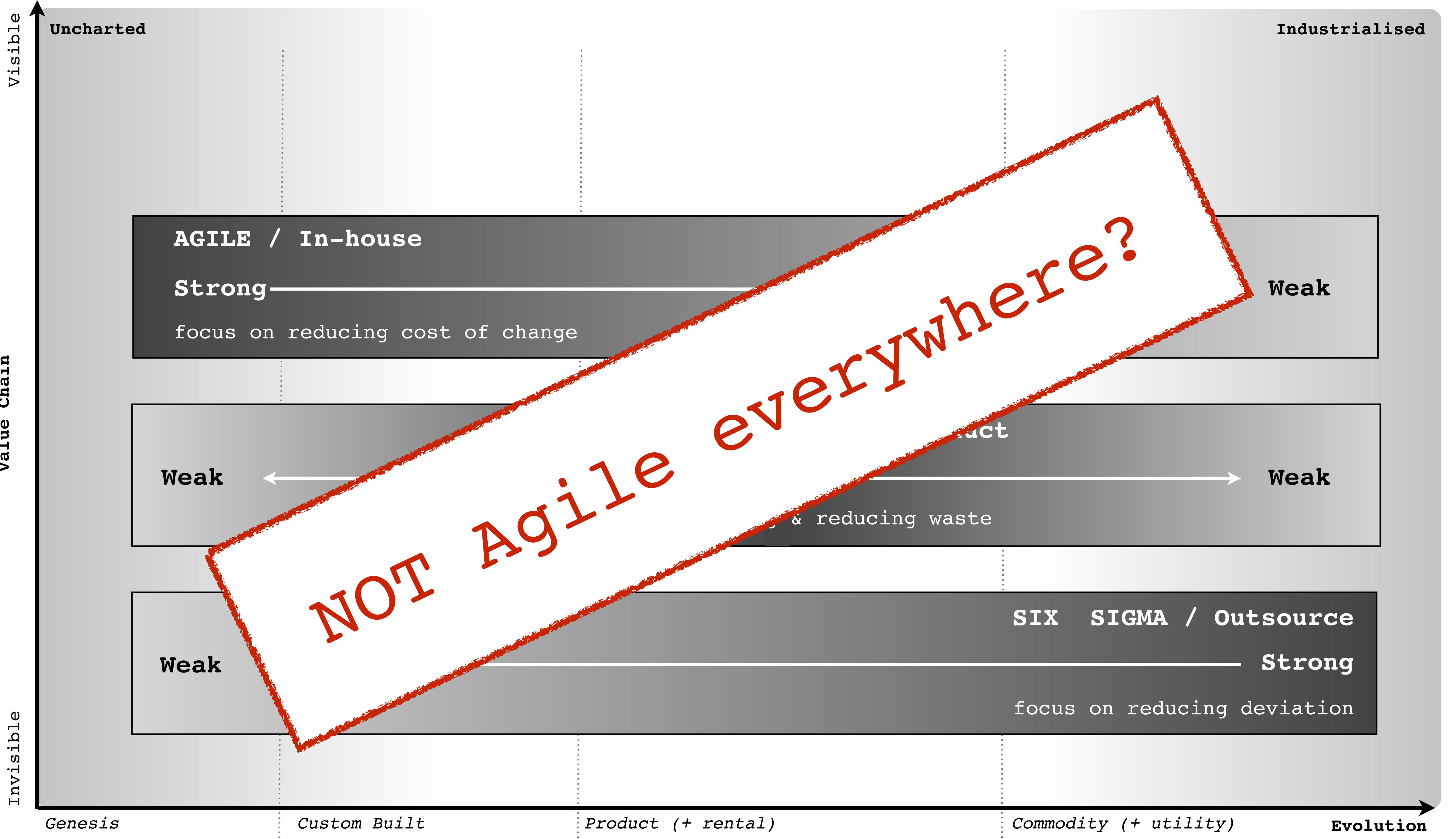

Three ginger cats are dressed as medieval figures in red robes. The cat on the left wears a black hood. The middle cat wears a red hat. The cat on the right wears a red hood and holds a wooden staff. Two white speech bubbles are overlaid on the image. The first speech bubble, on the left, contains the text "Heretic!". The second speech bubble, on the right, contains the text "Burn him!".

Heretic!

Burn him!



Systems Diagram

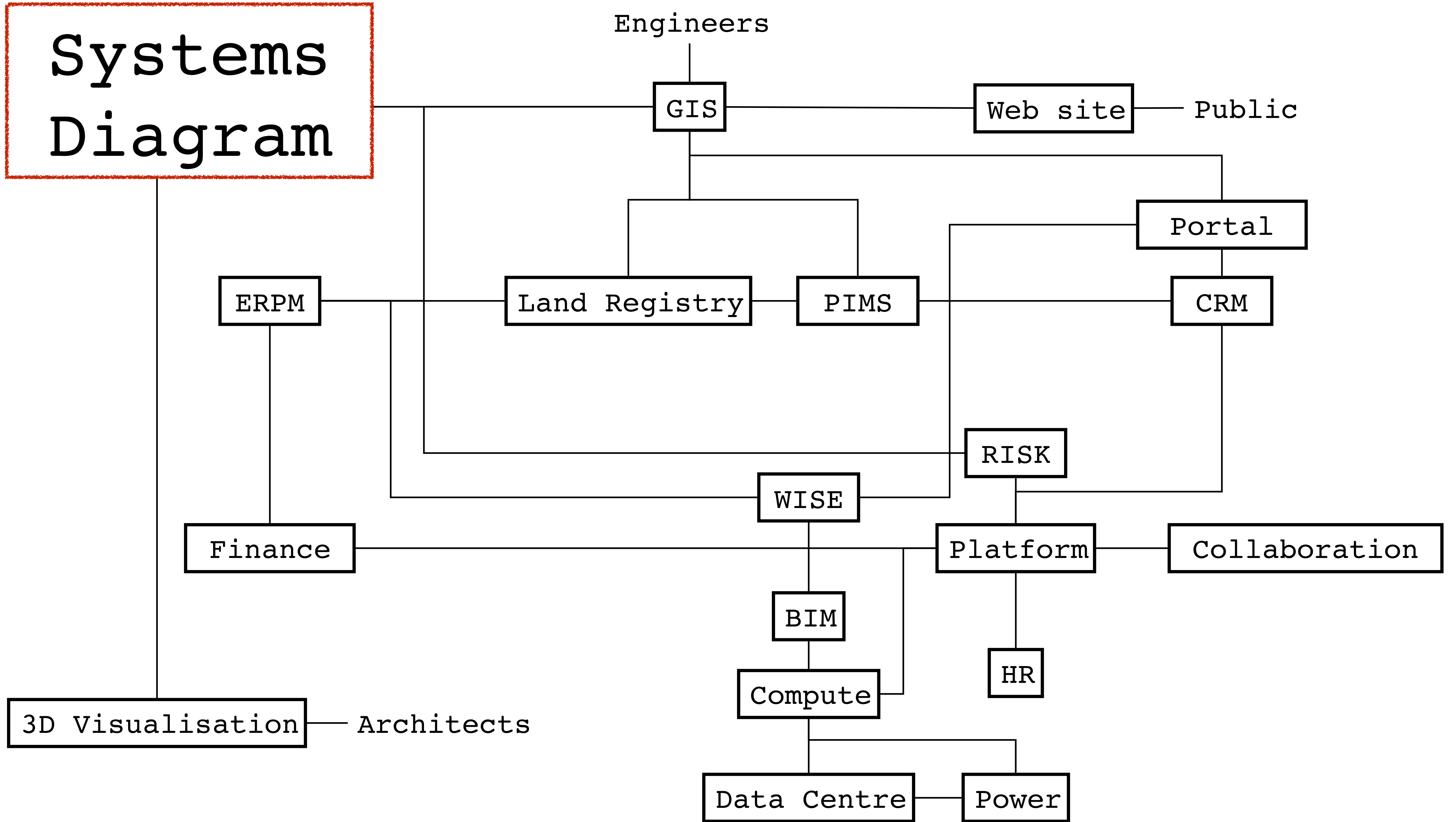

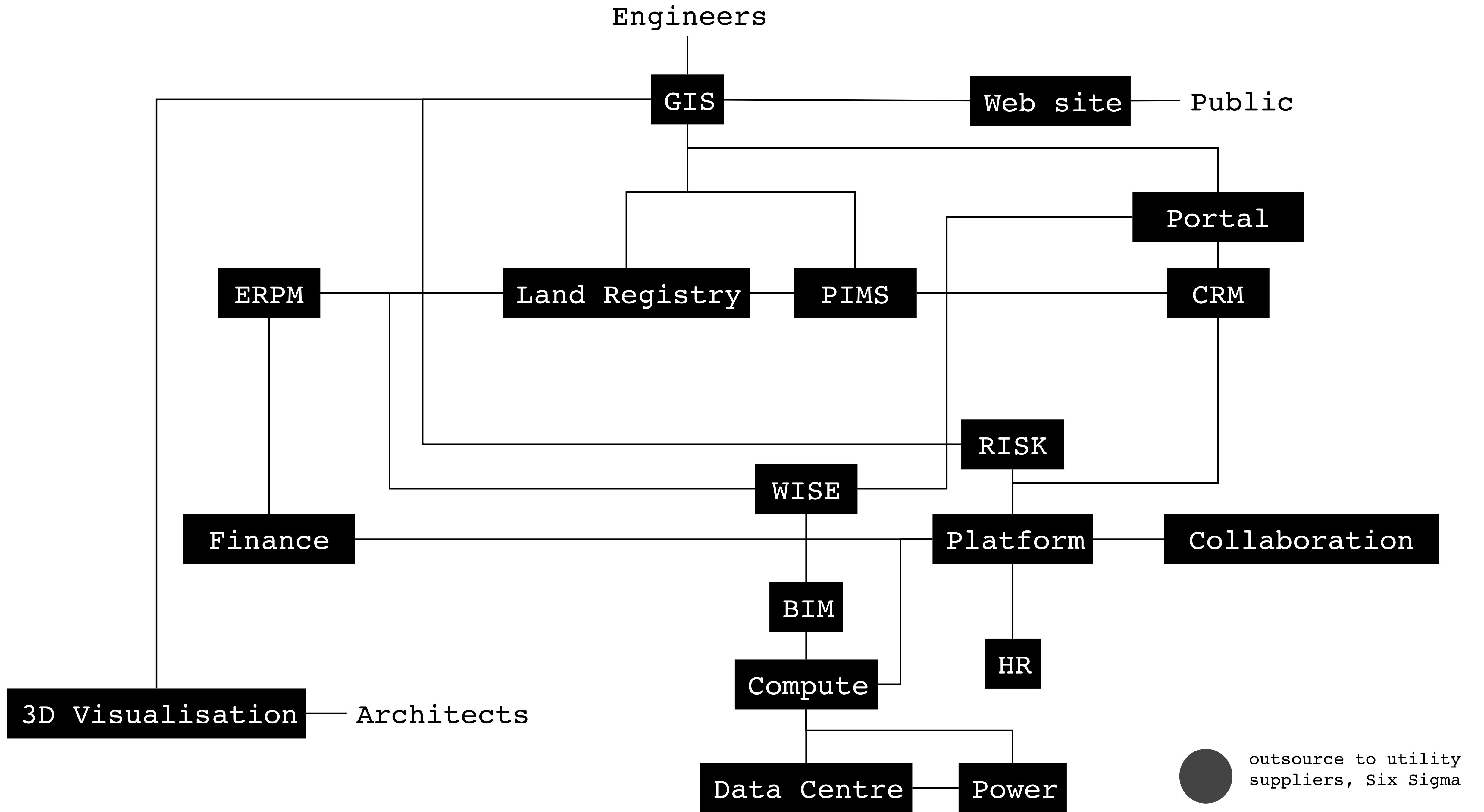

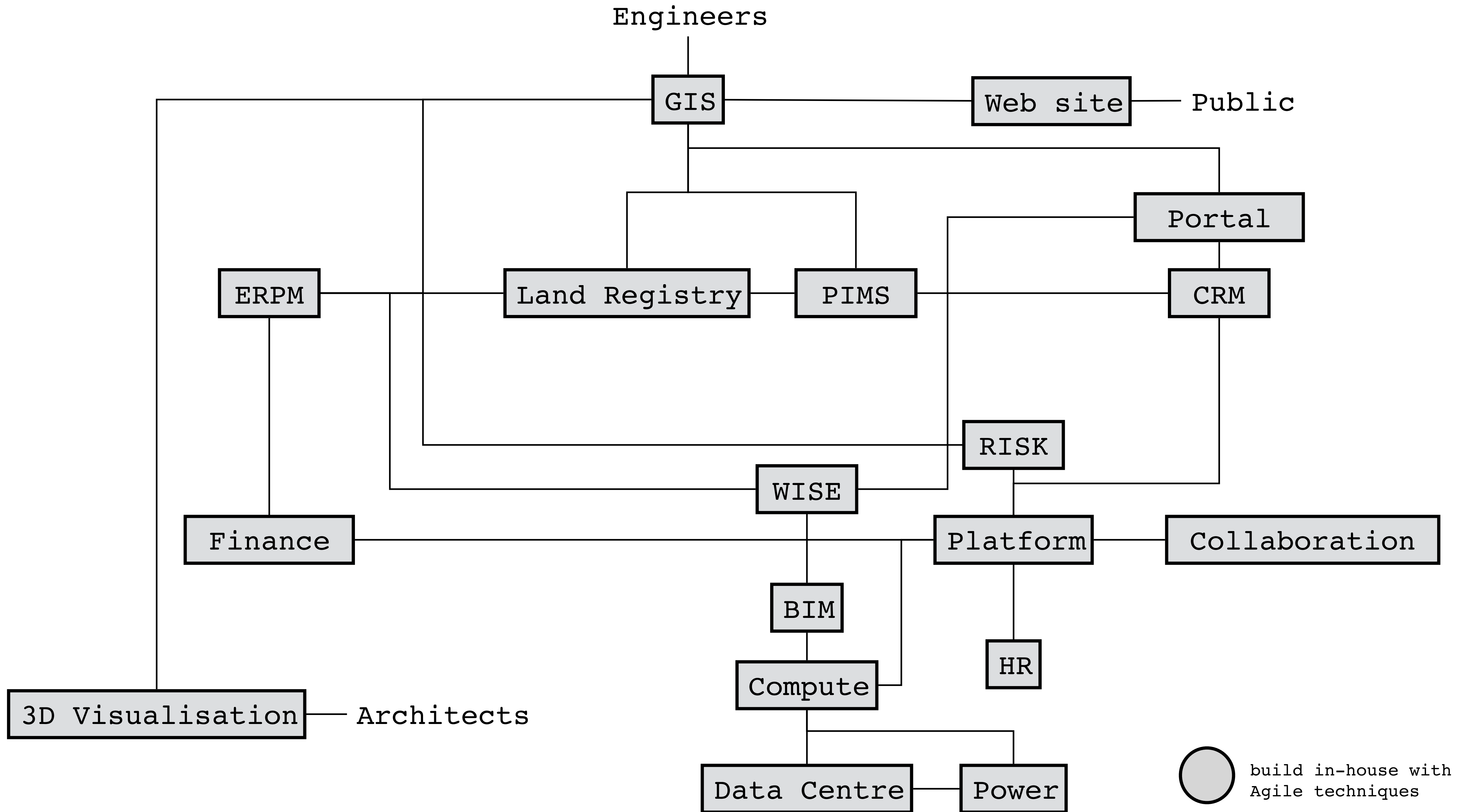

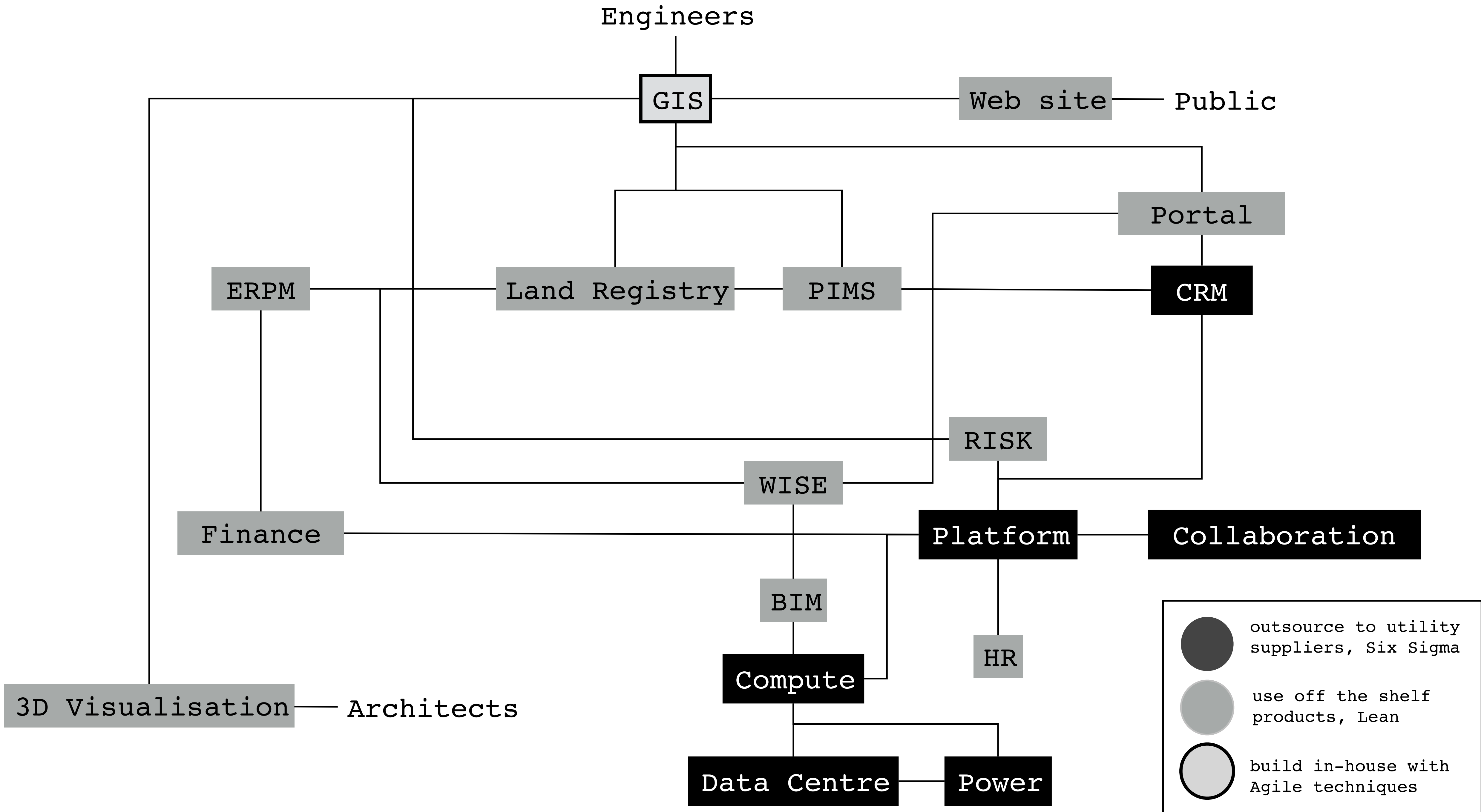

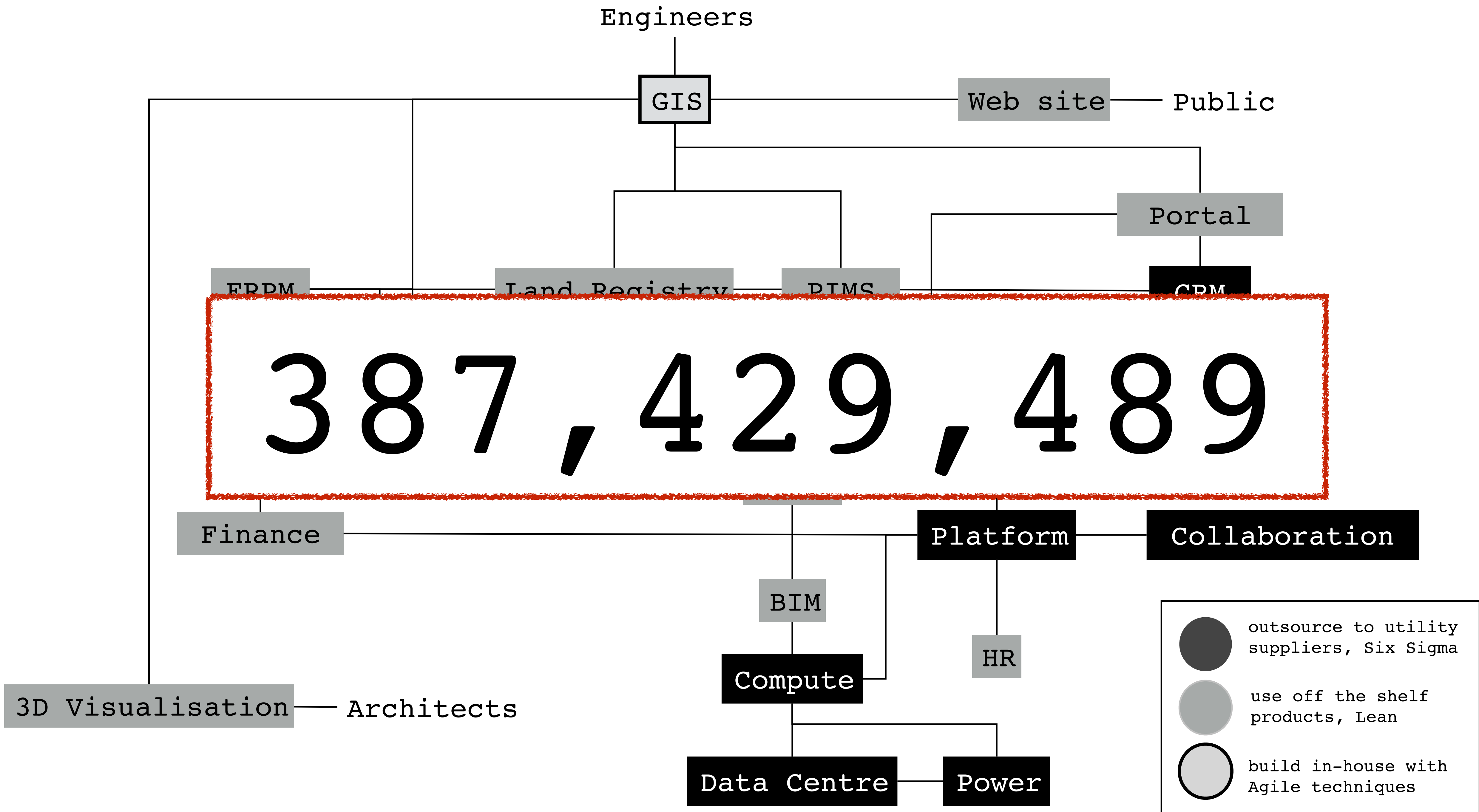

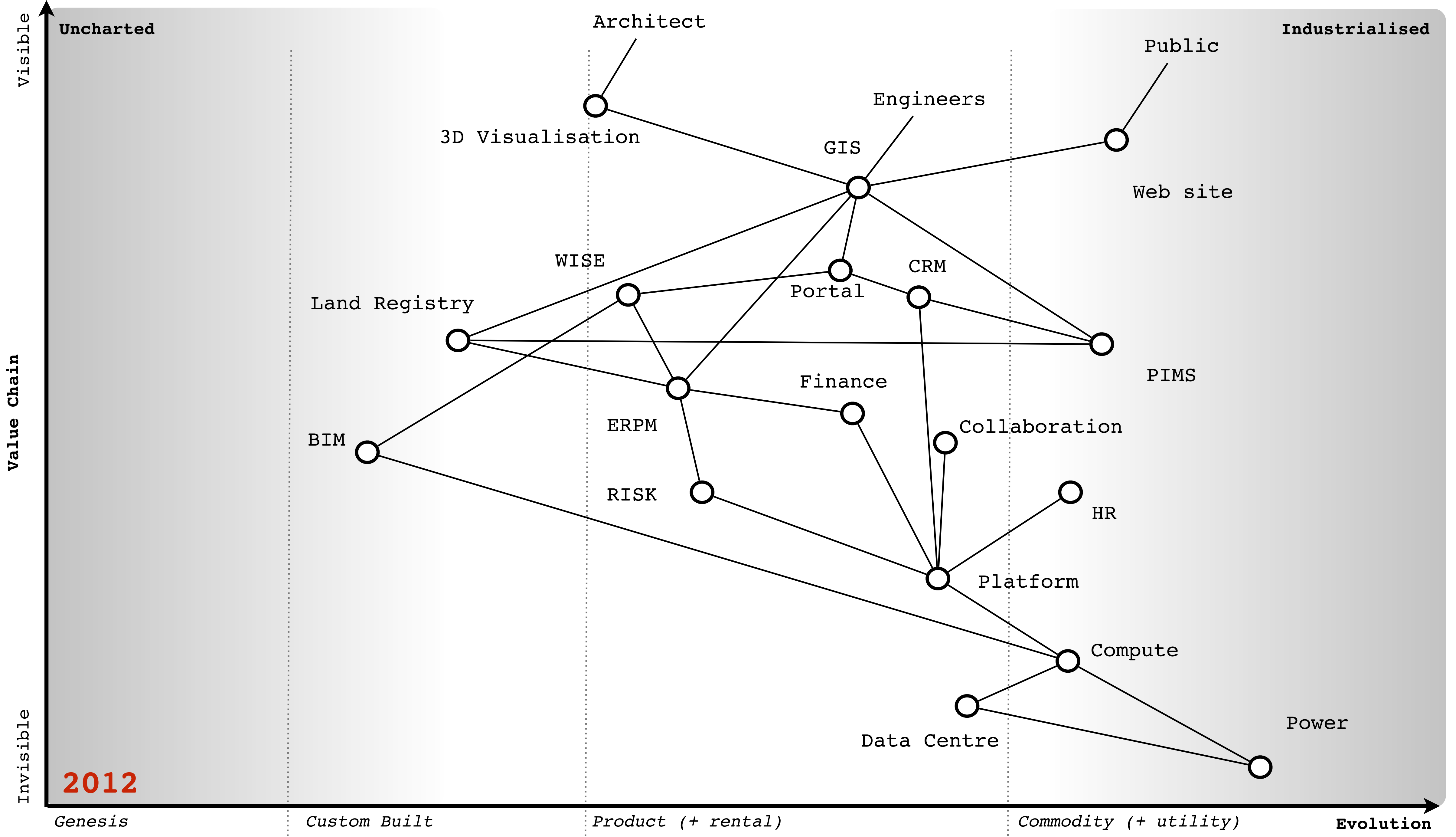

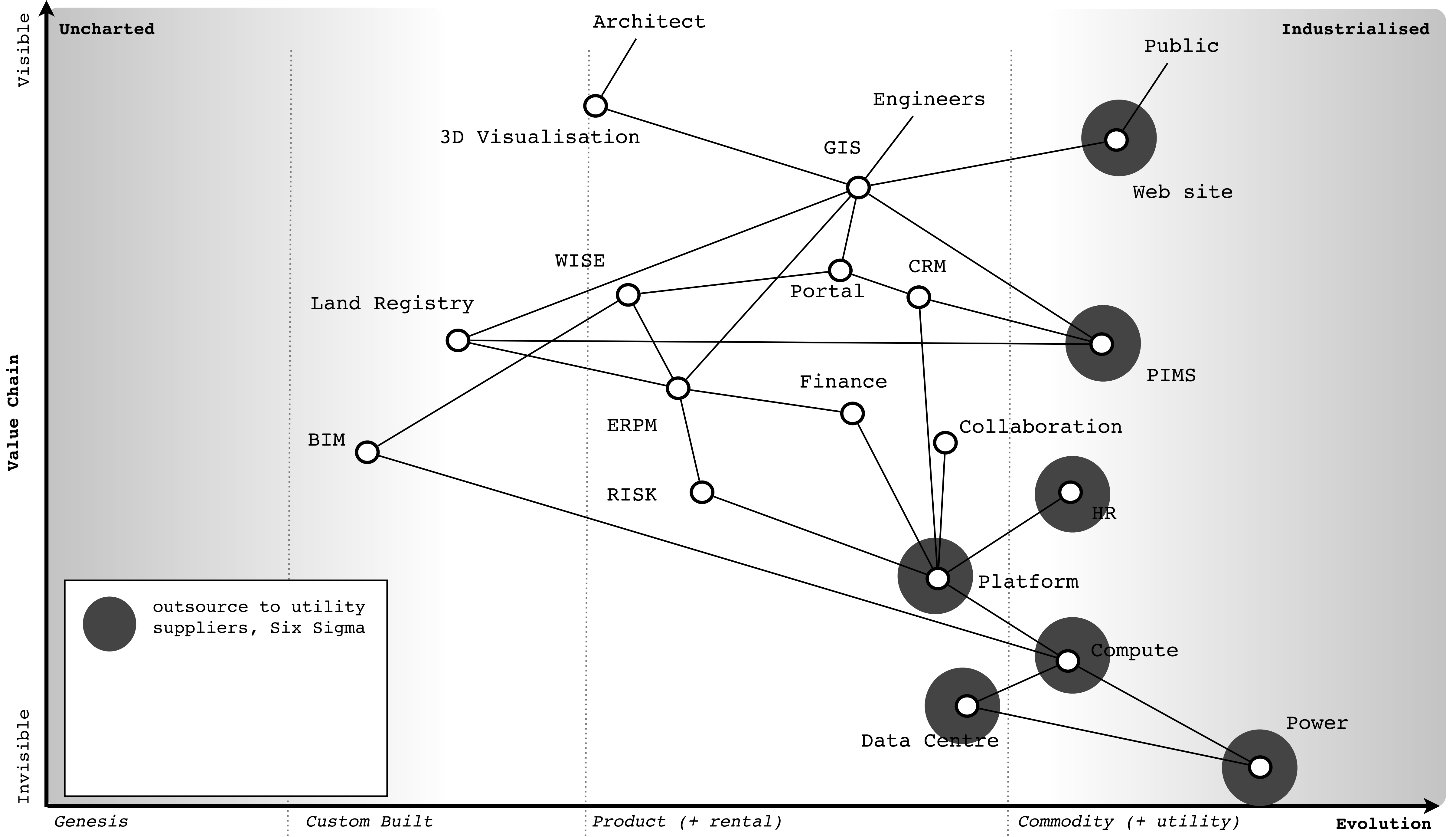

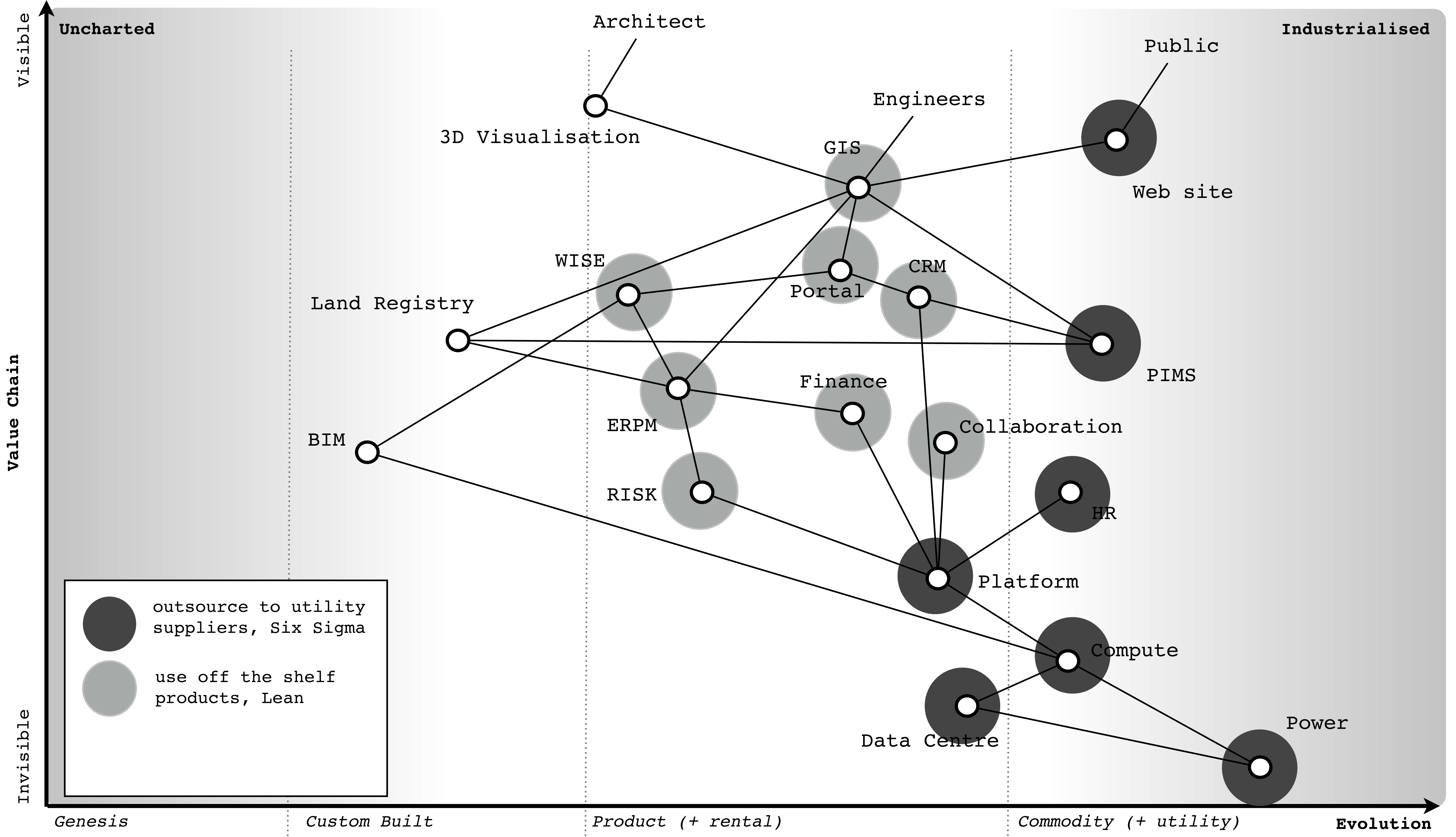

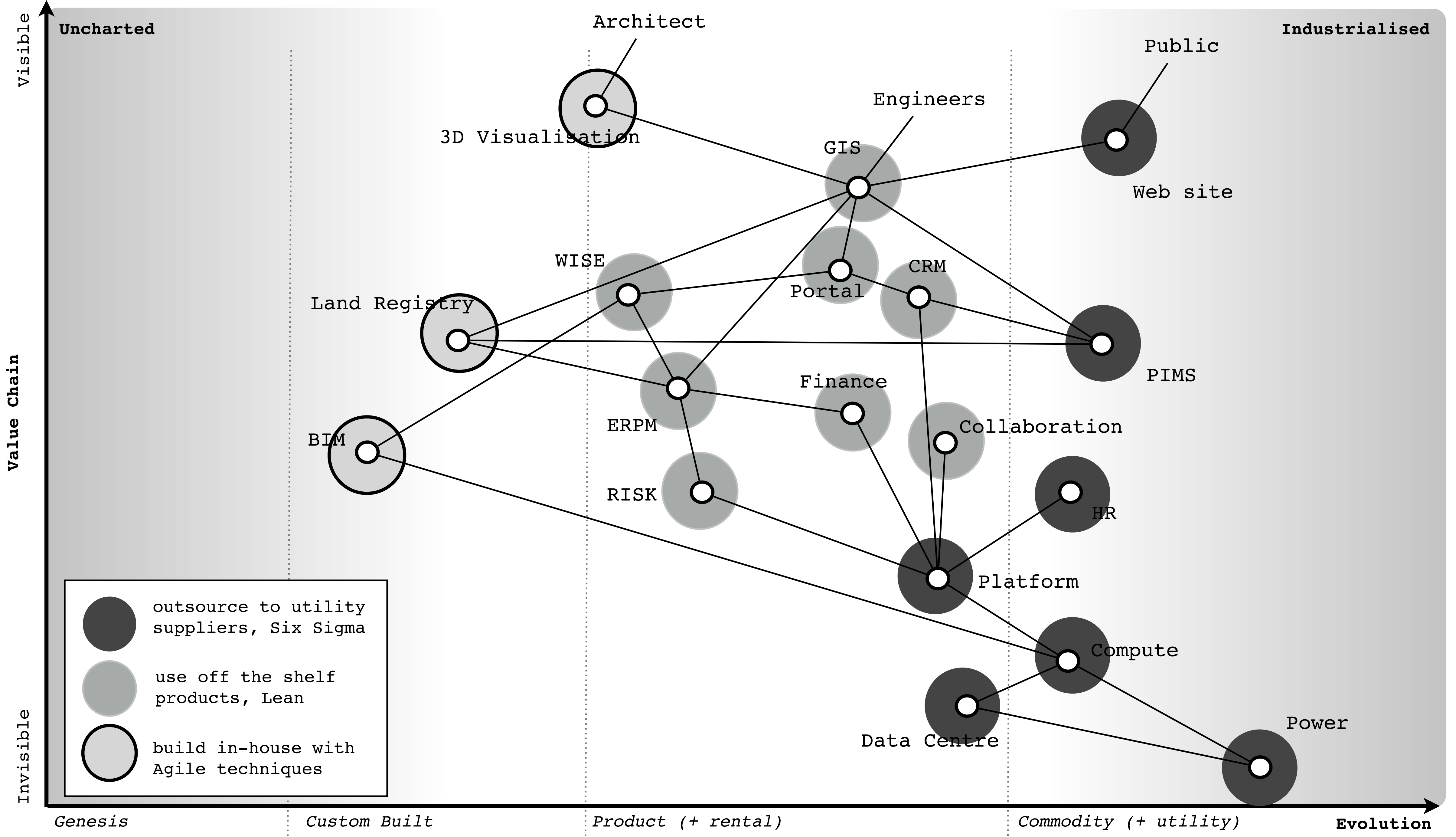

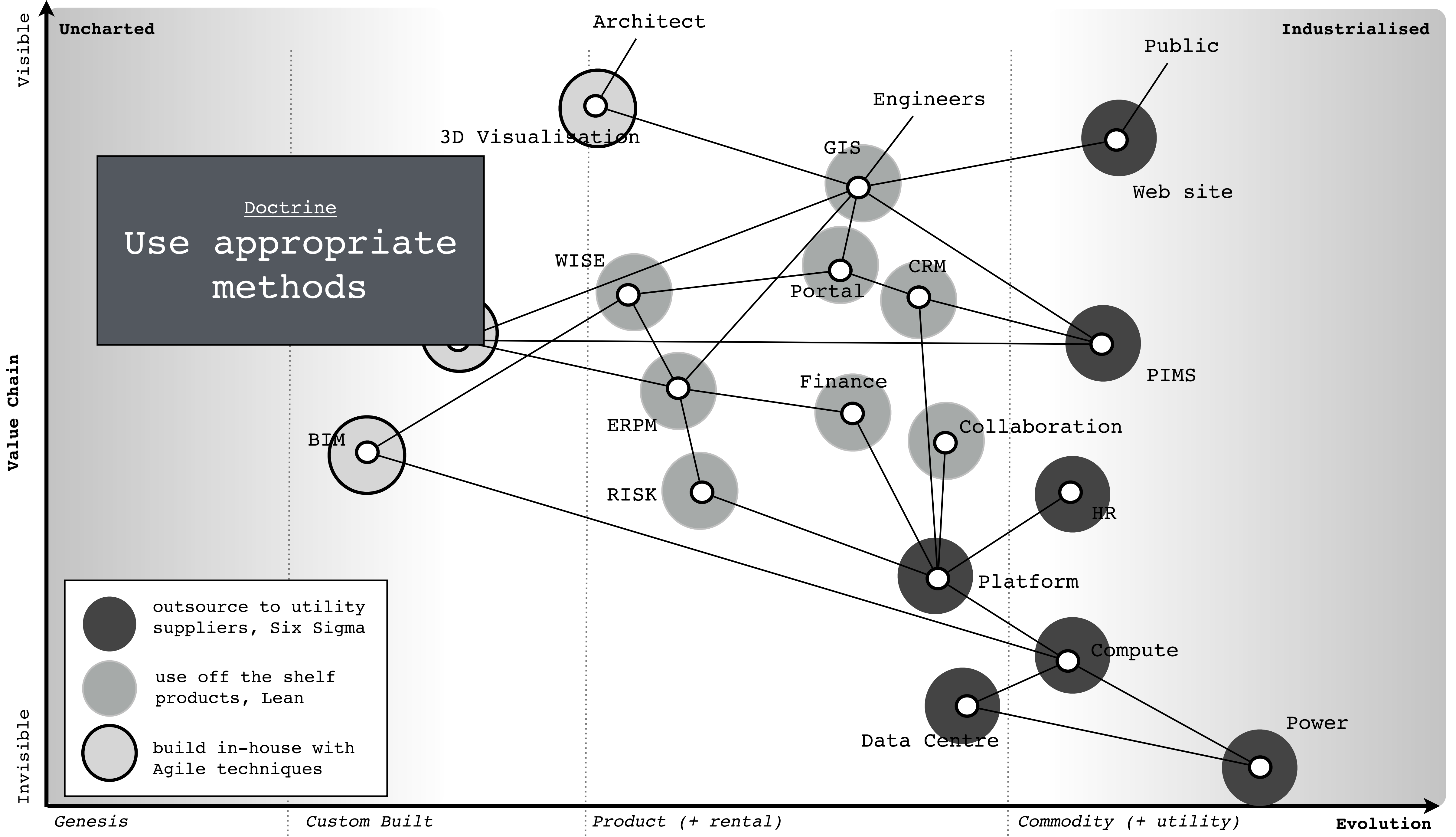

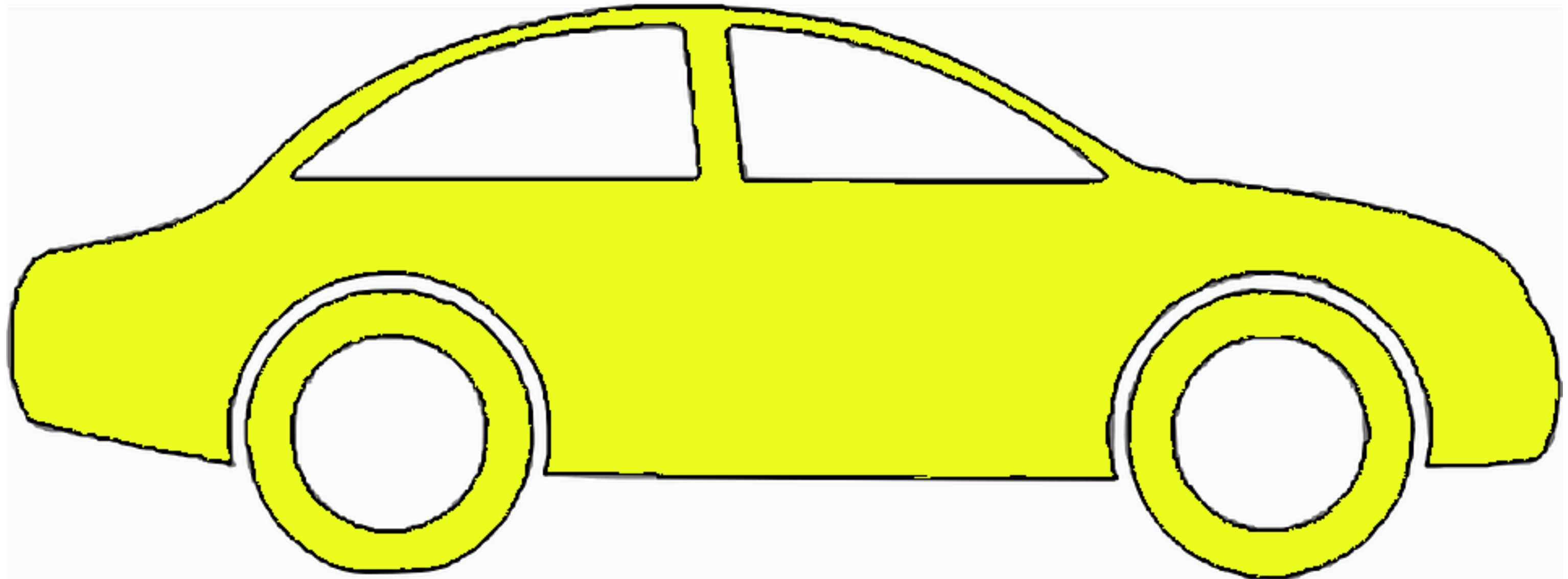

ብ

ከተማዎች ከአገር ጋር

አገር ለግን ለሌሎች

ግን

ግን

ግን ግን አገር

ግን ግን ግን ለሌሎች

ግን ግን

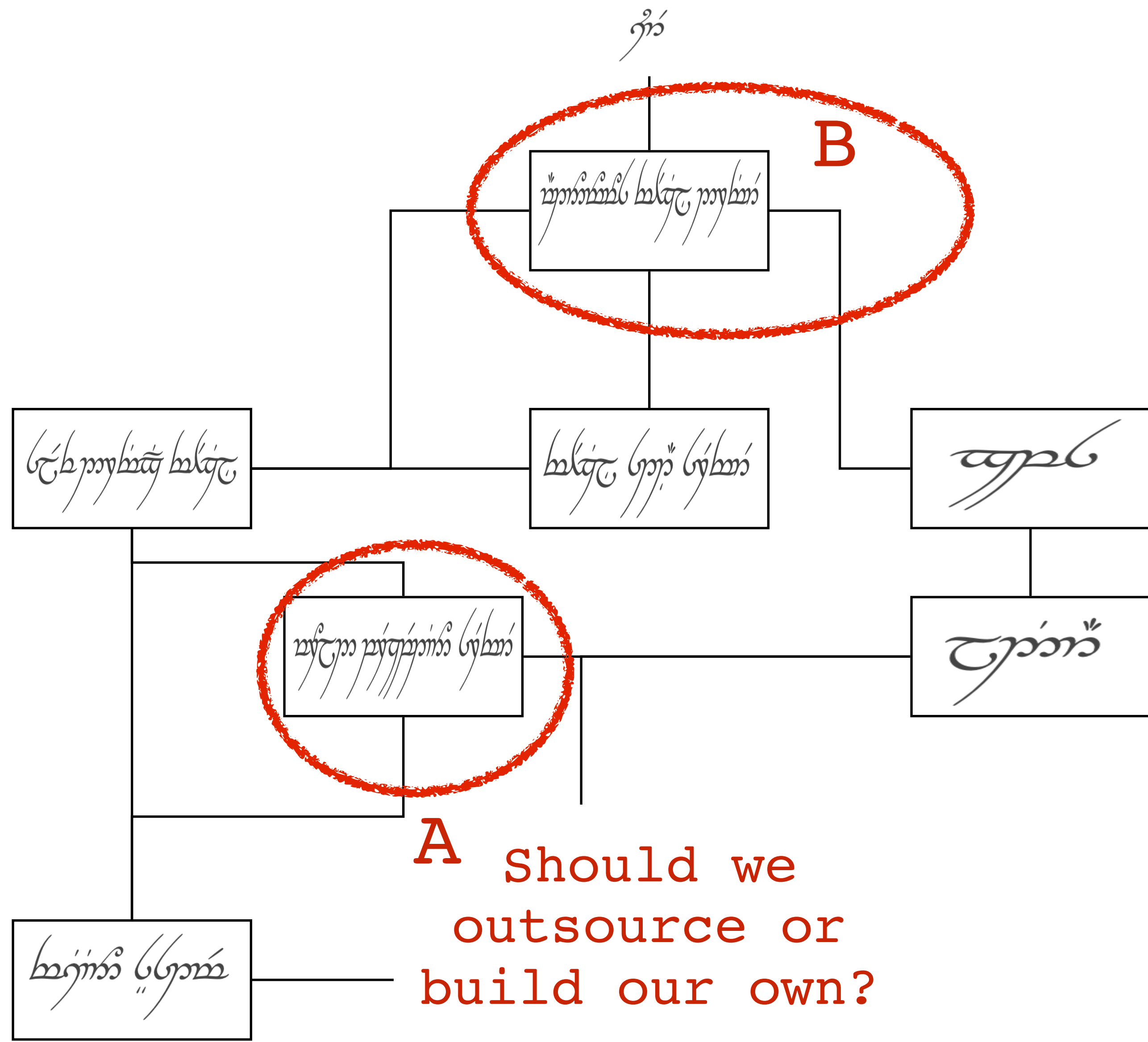

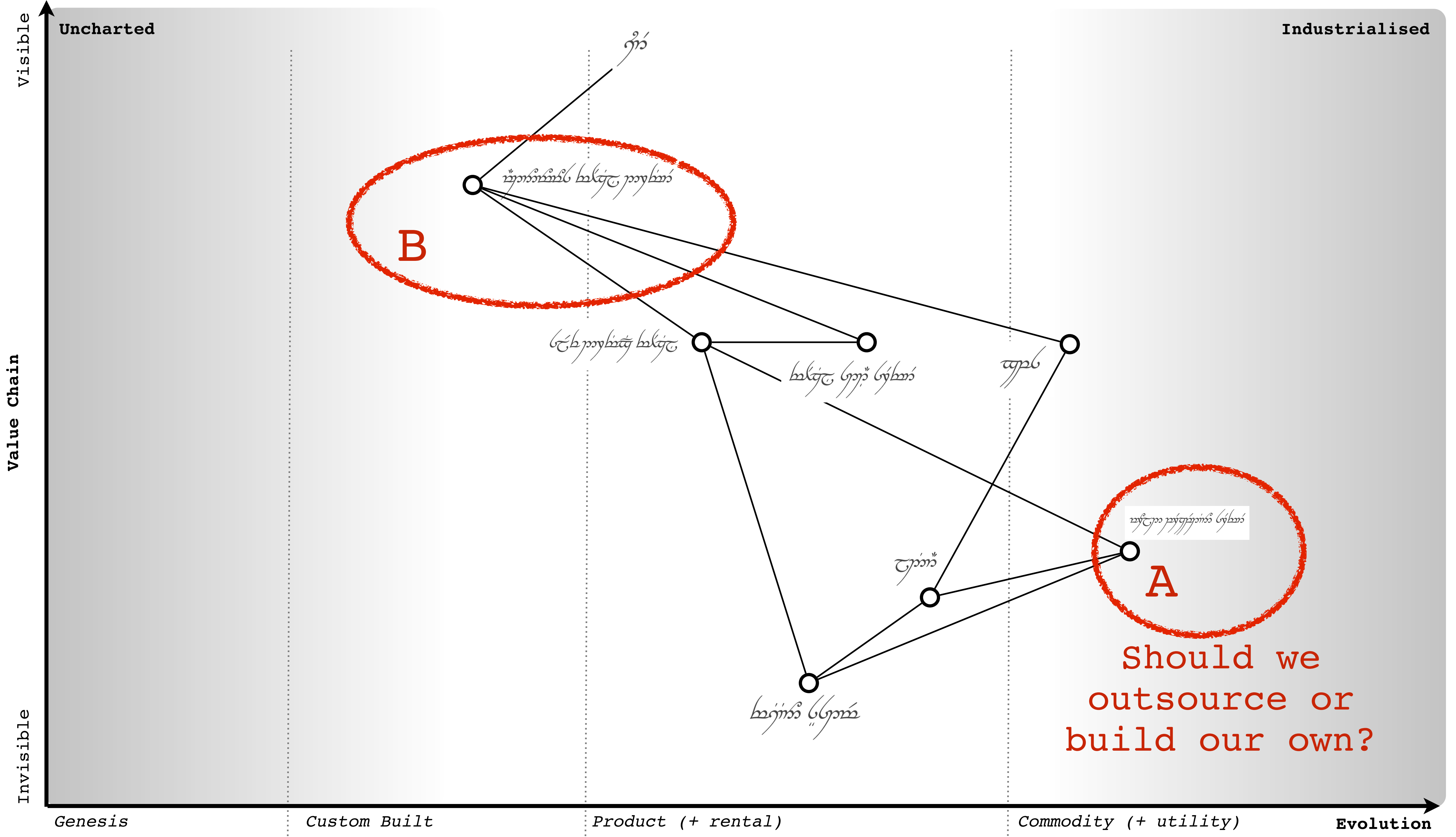

Visible

Uncharted

Industrialised

Value Chain

Invisible

Genesis

Custom Built

Product (+ rental)

Commodity (+ utility)

Evolution

B

A

Should we
outsource or
build our own?

Strategy

Maps

Communication

Patterns

Anticipation

Organisation

Leadership

N

SERVERLESS

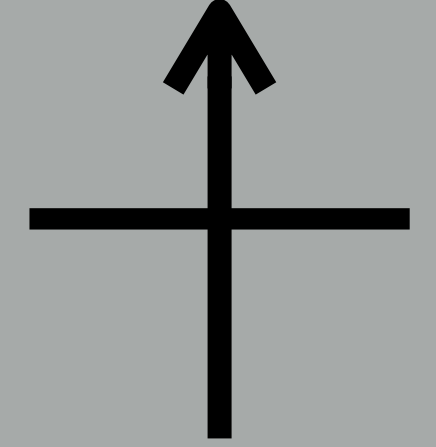
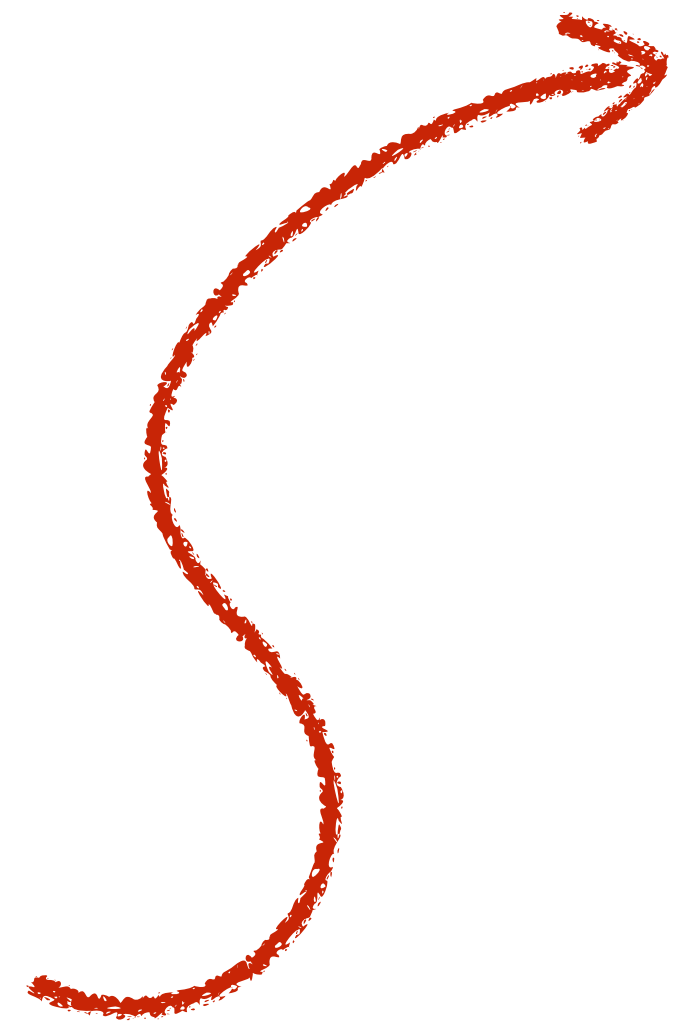
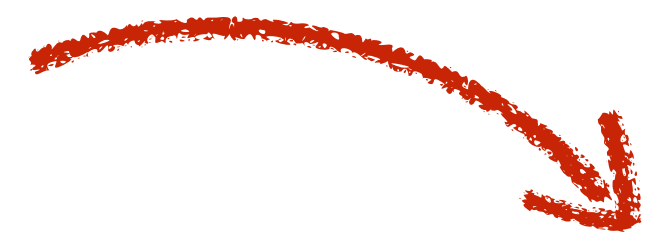

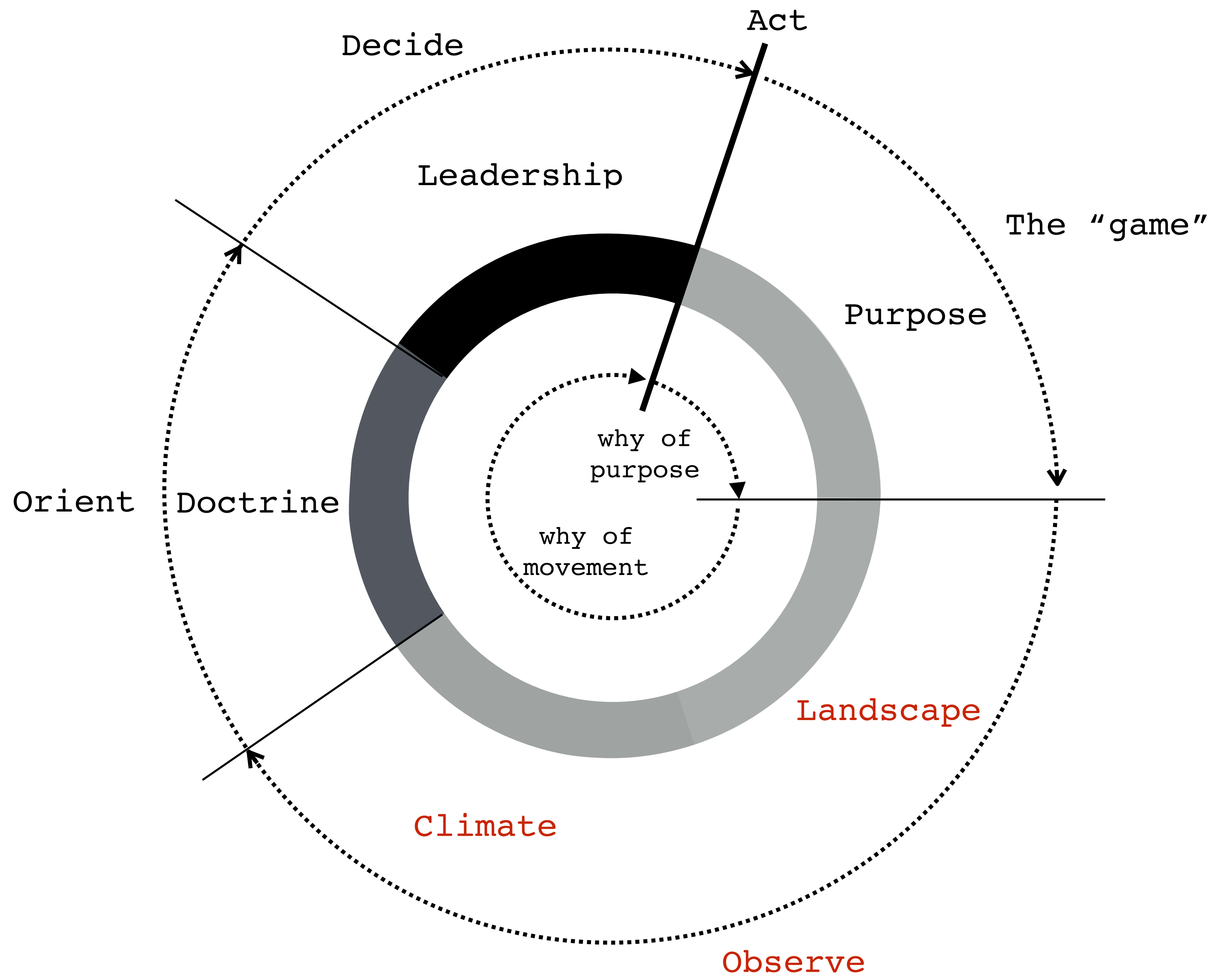

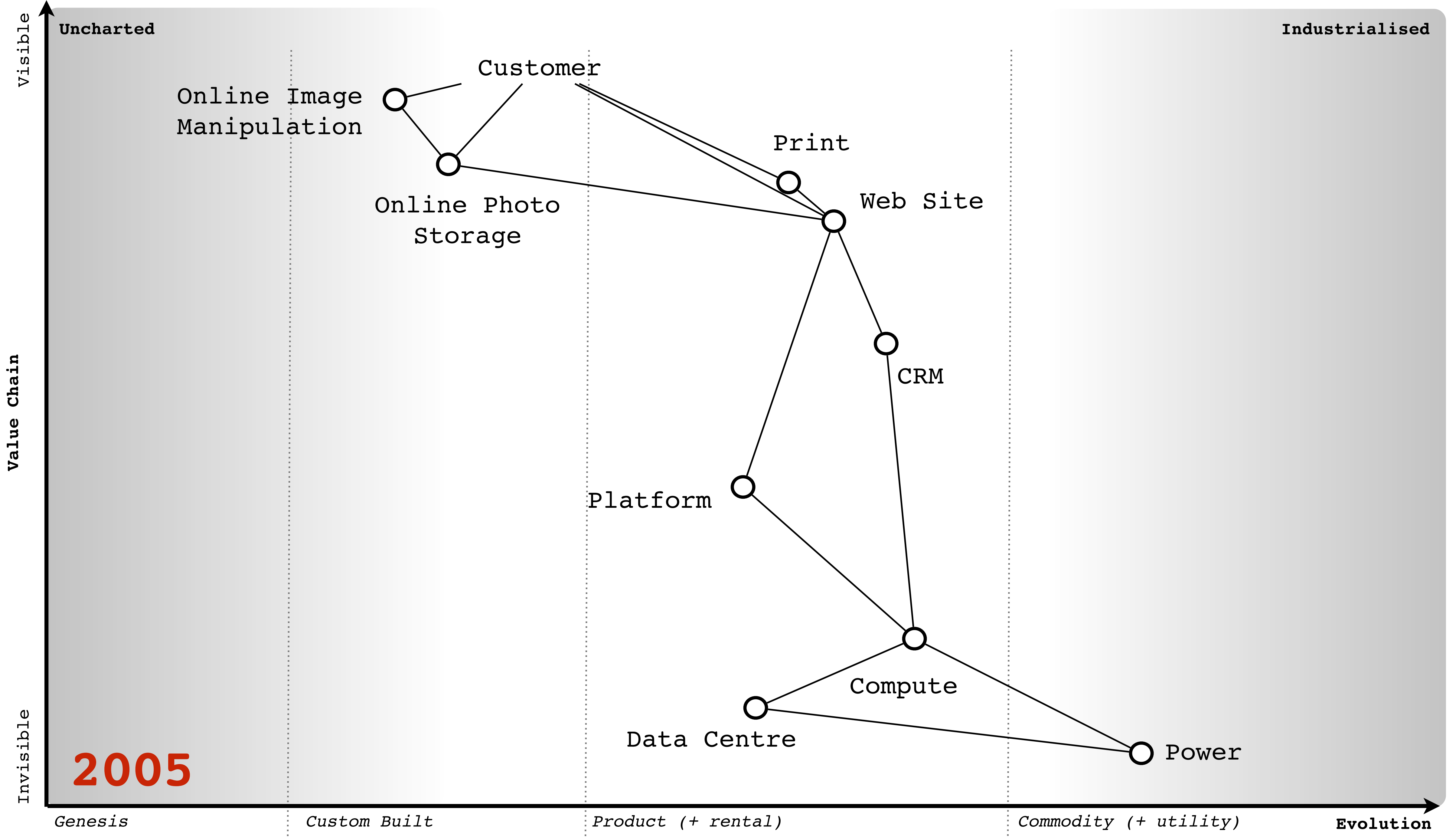

Uncharted

Industrialised

Visible

Value Chain

Invisible

Online Image Manipulation

Customer

Online Photo Storage

Print

Web Site

CRM

Platform

Compute

Data Centre

Power

2005

Genesis

Custom Built

Product (+ rental)

Commodity (+ utility)

Evolution

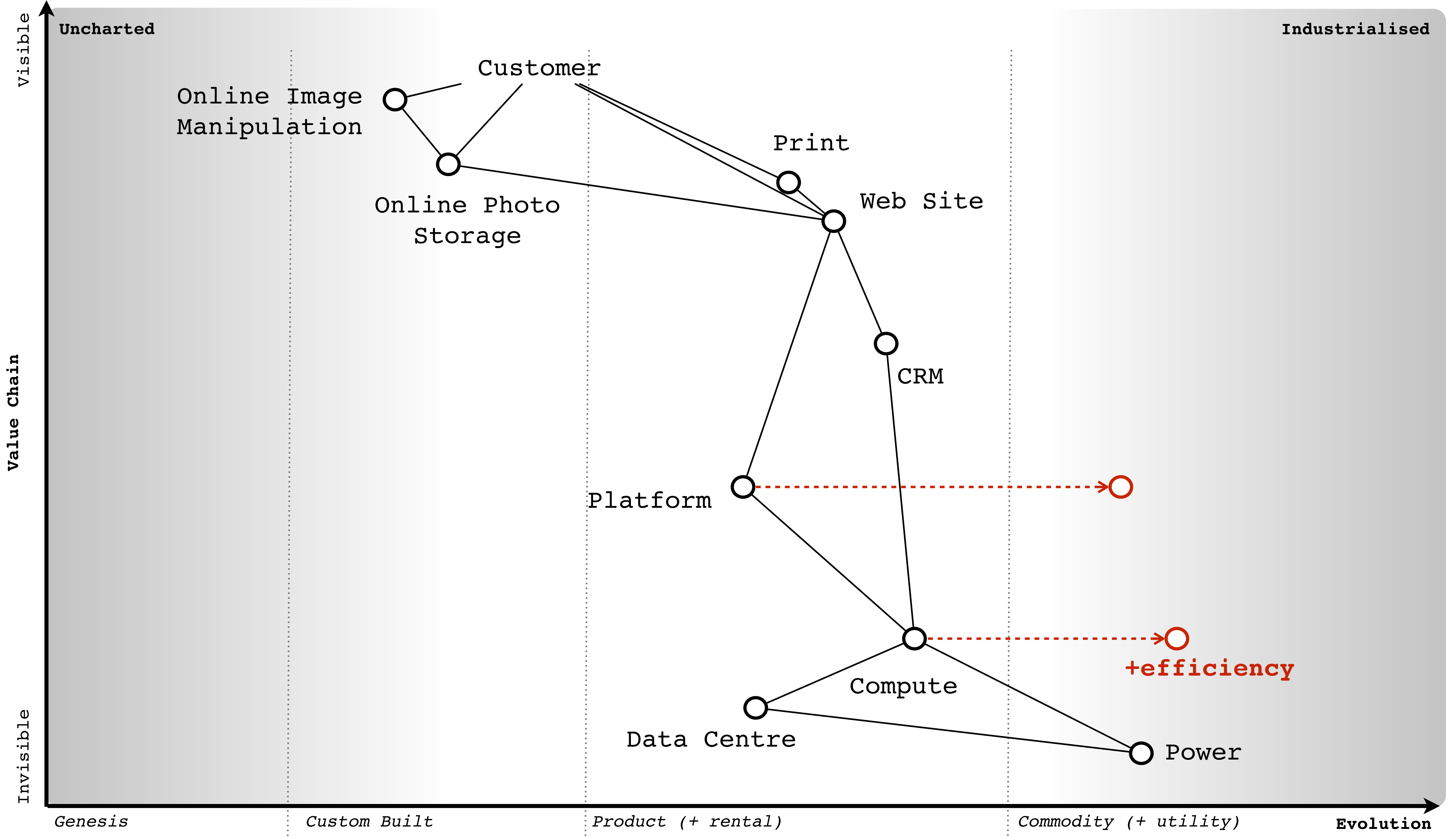

Uncharted

Industrialised

Visible

Value Chain

Invisible

Online Image Manipulation

Customer

Online Photo Storage

Print

Web Site

CRM

Platform

Compute

Data Centre

+efficiency

Power

Genesis

Custom Built

Product (+ rental)

Commodity (+ utility)

Evolution

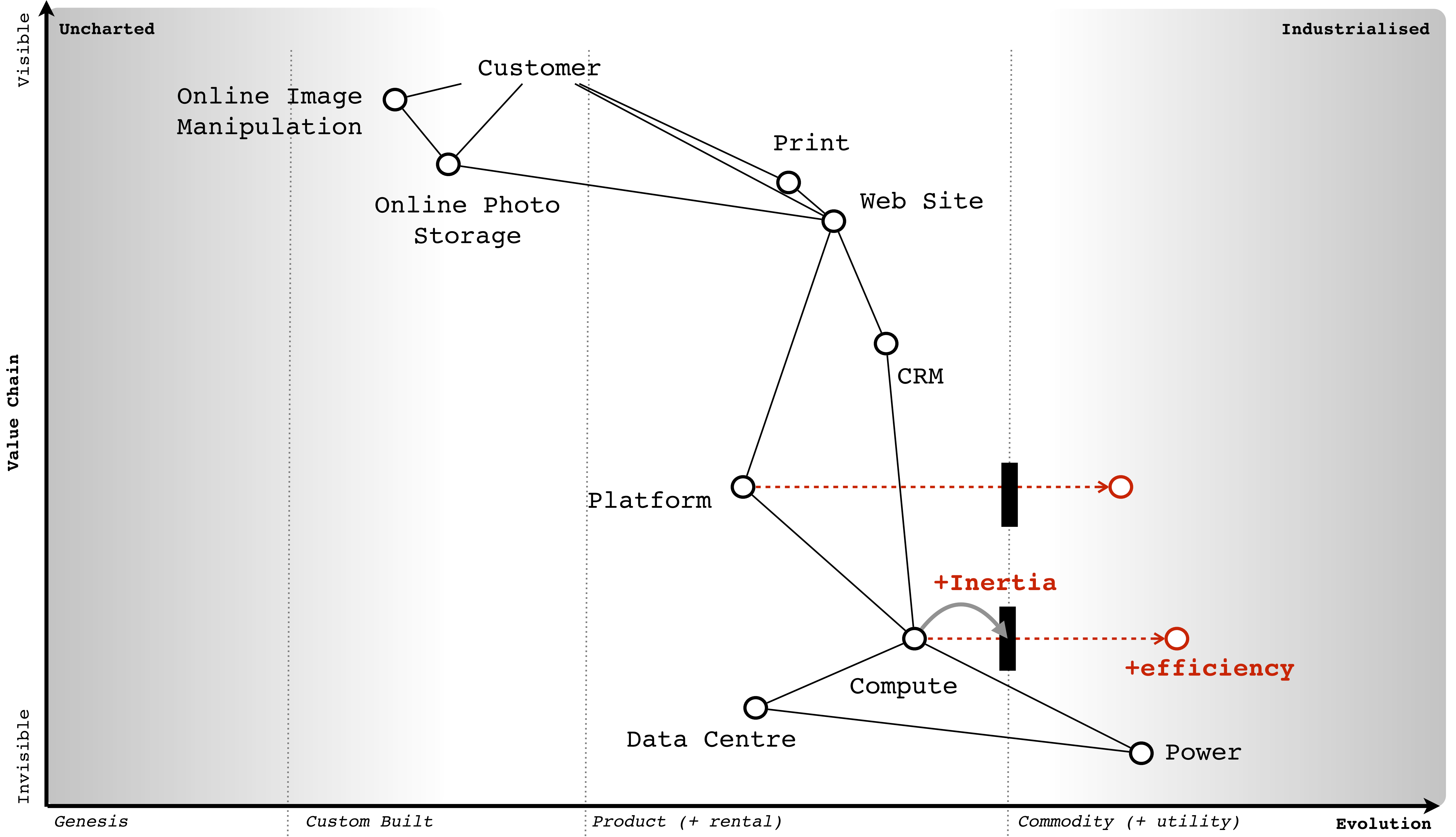

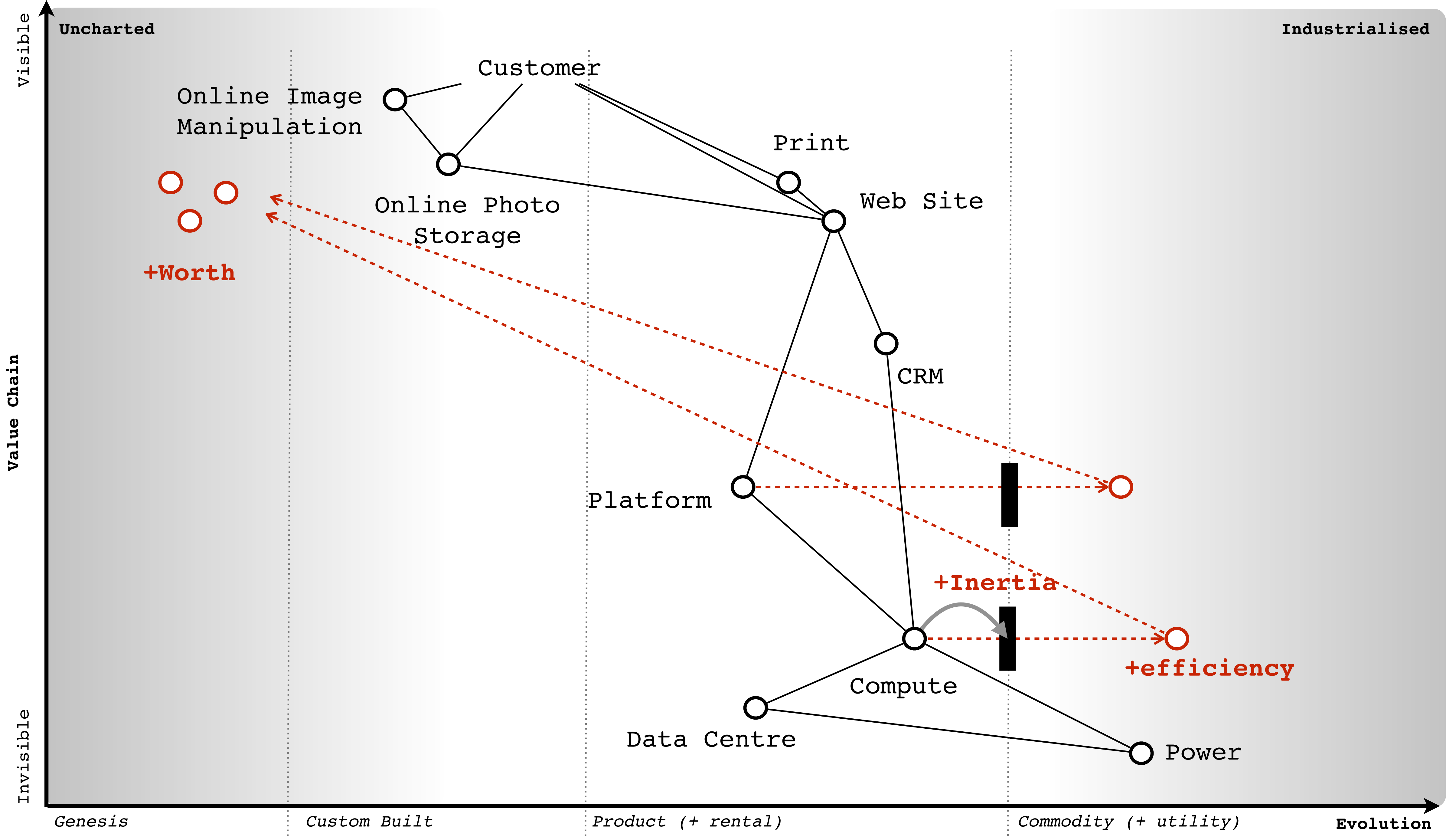

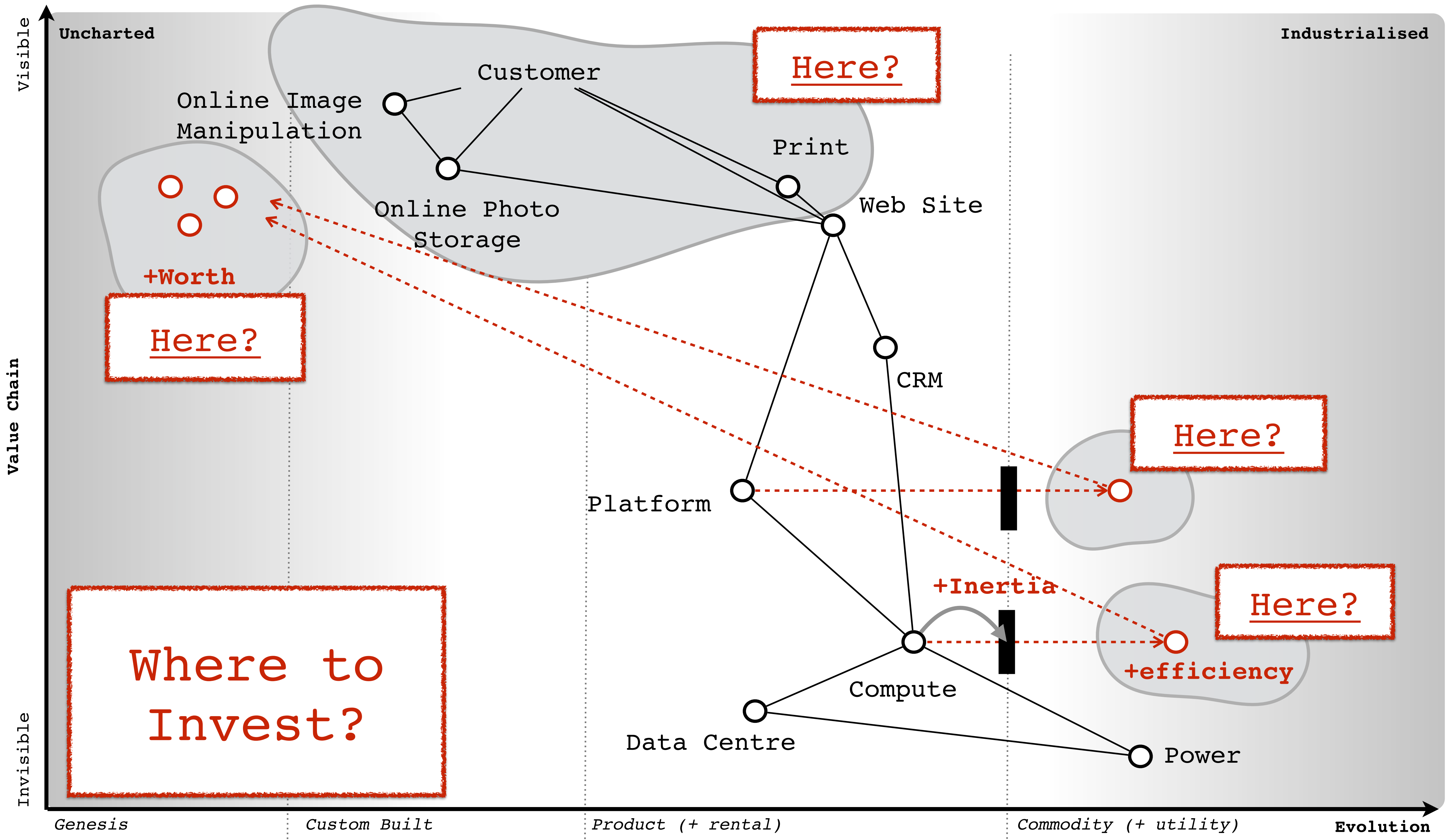

Strategy



Maps

Communication



Patterns

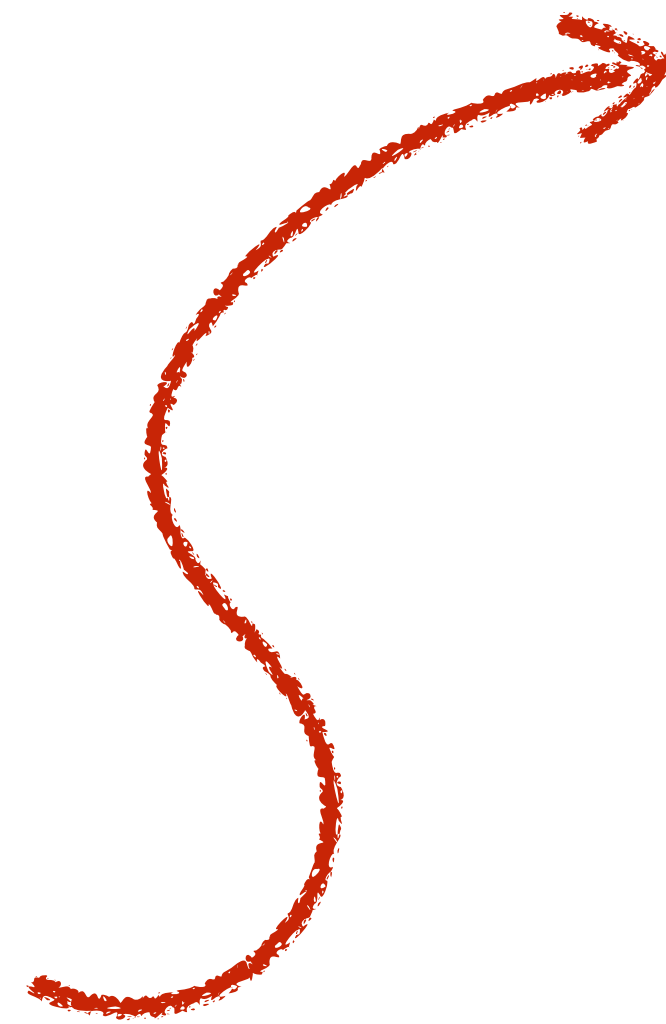

Anticipation

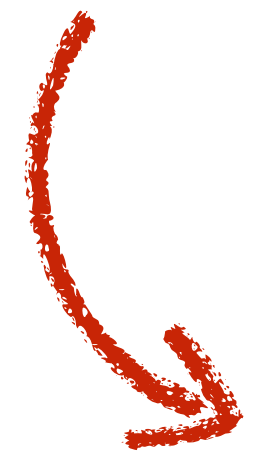

Organisation



Leadership

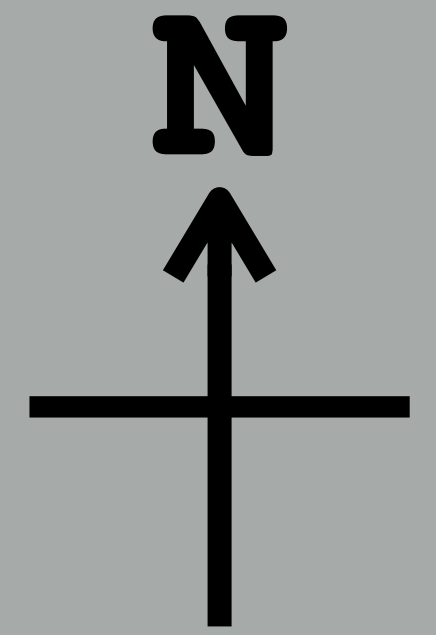

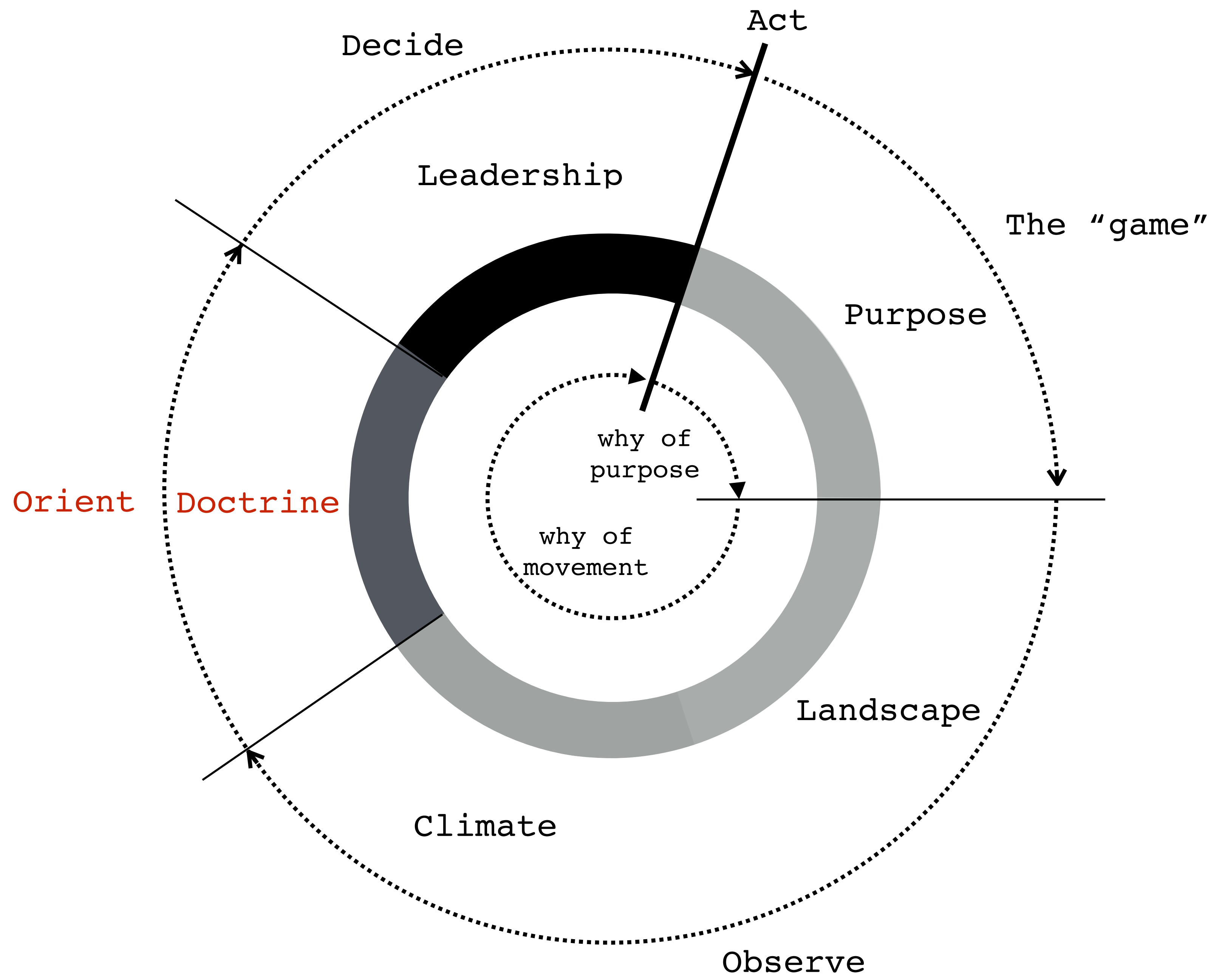

Doctrine

universally applicable
principles regardless of
context



**Emergency
Services Mobile
Communication
Platform (ESMCP)**

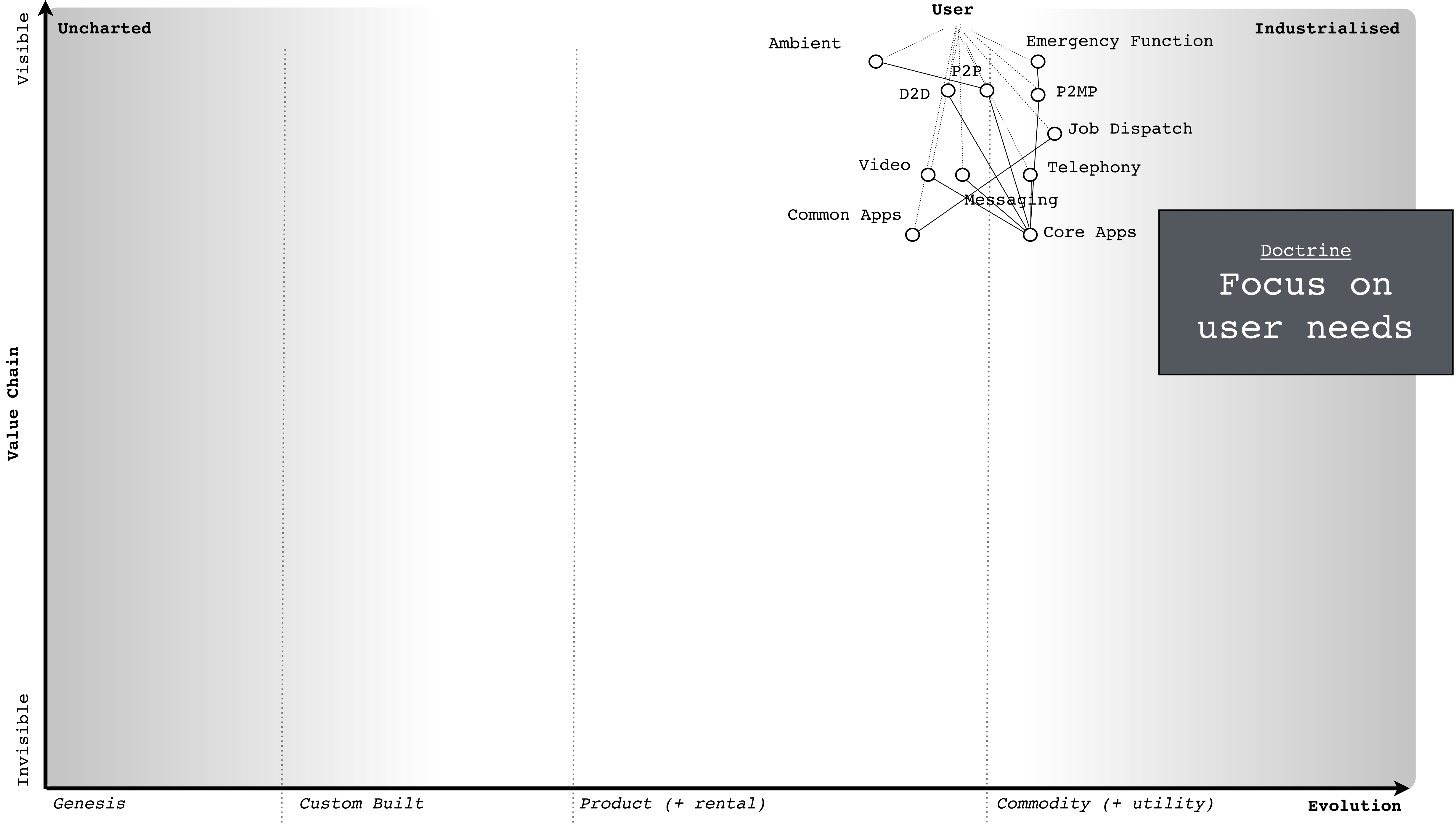

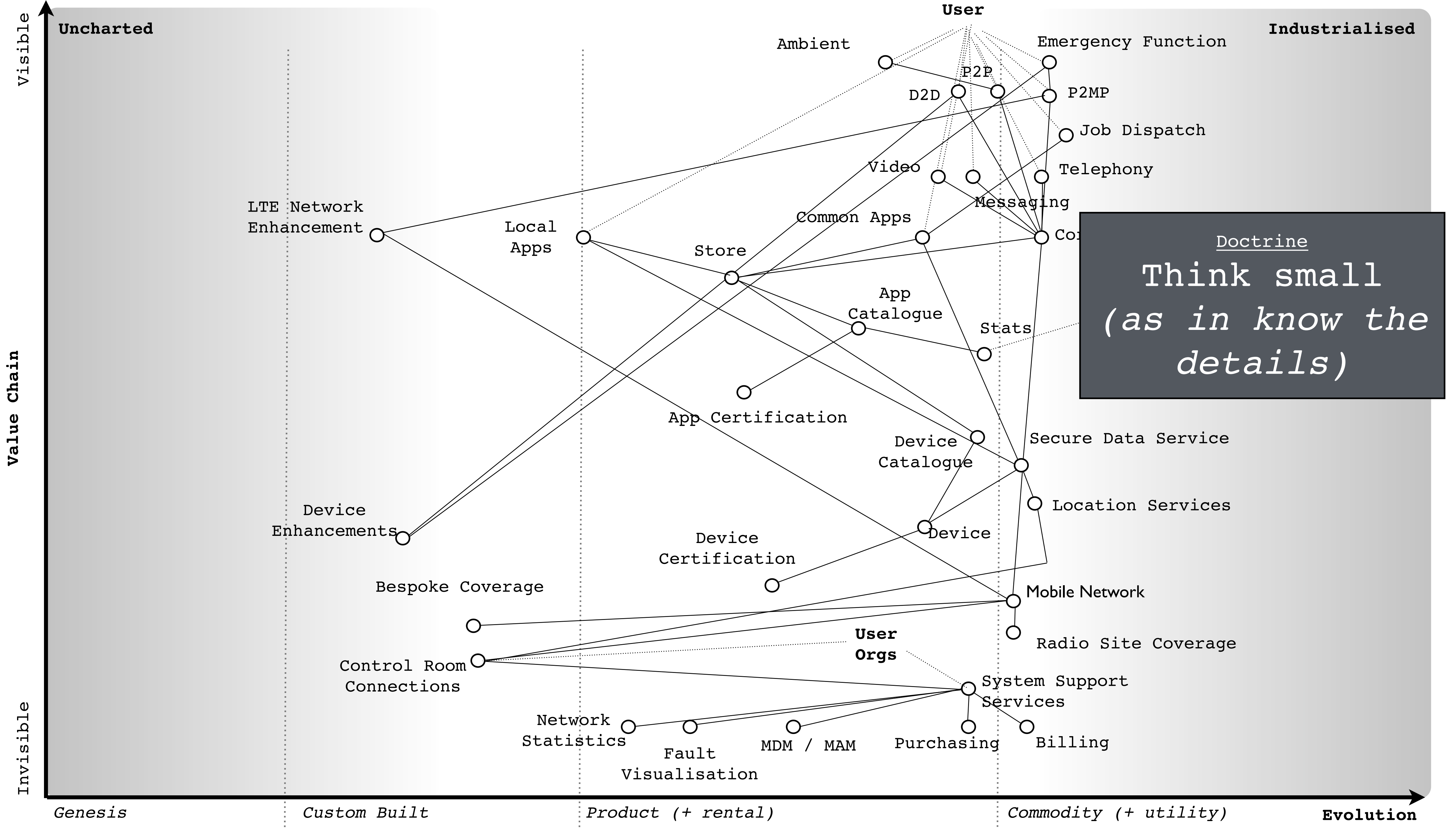

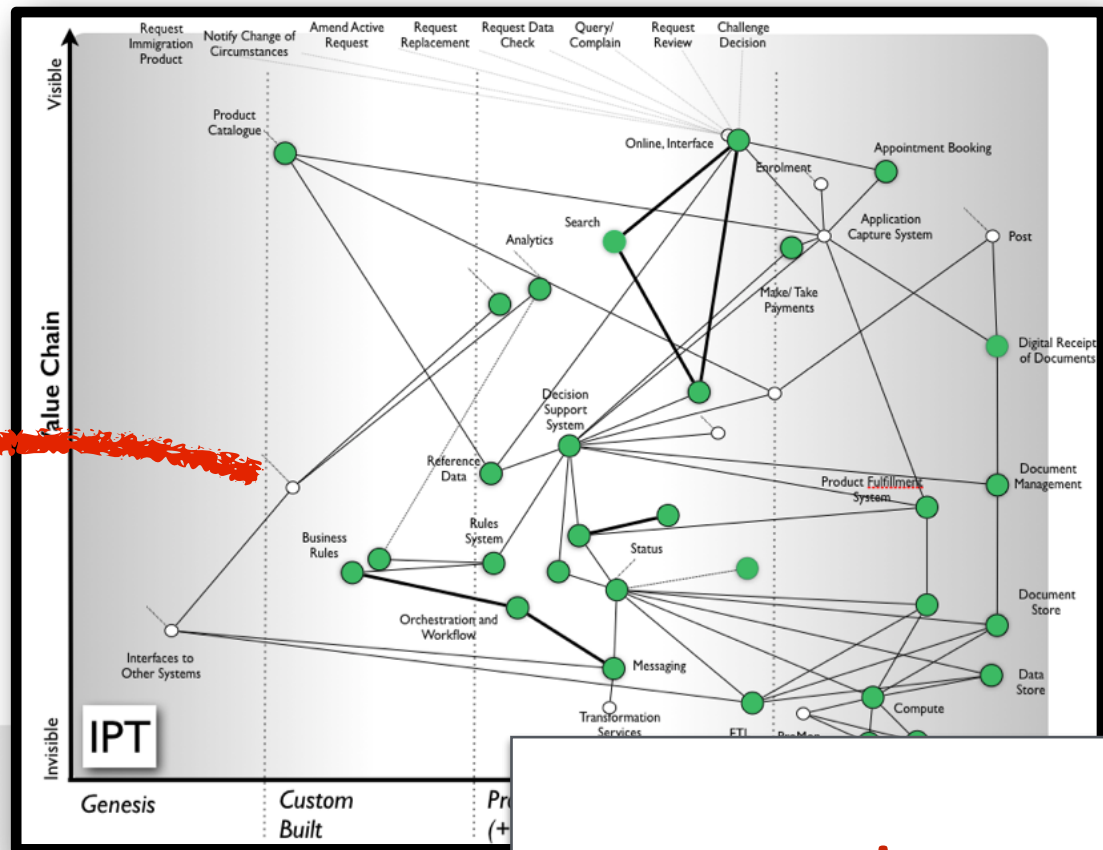
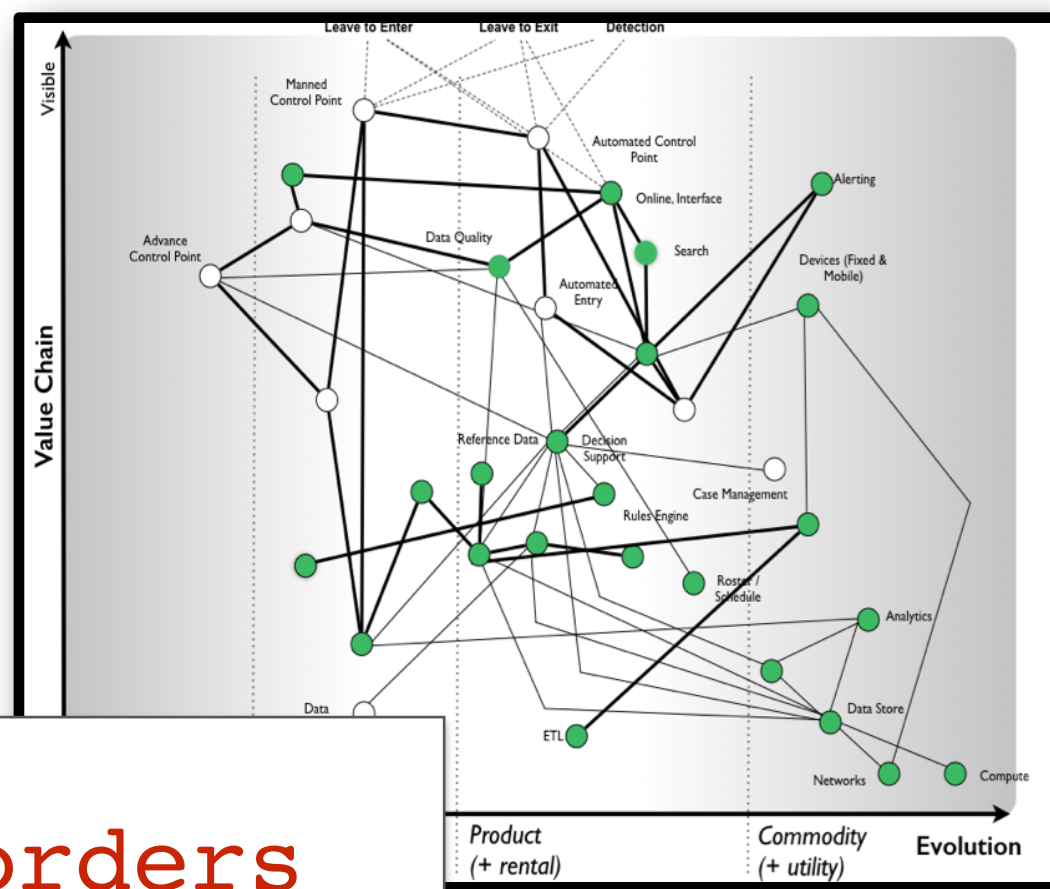

+Borders

+Immigration

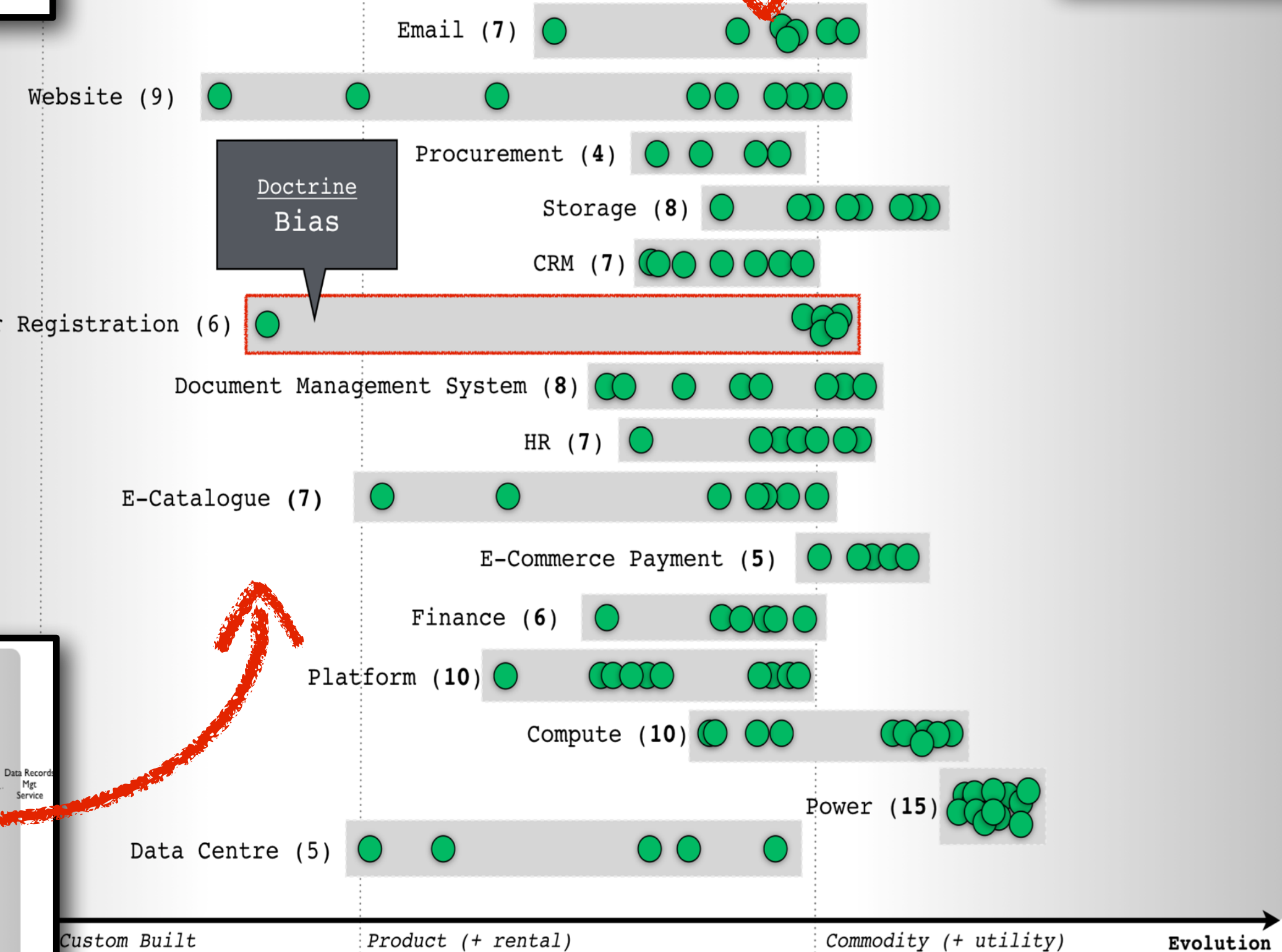

+Police

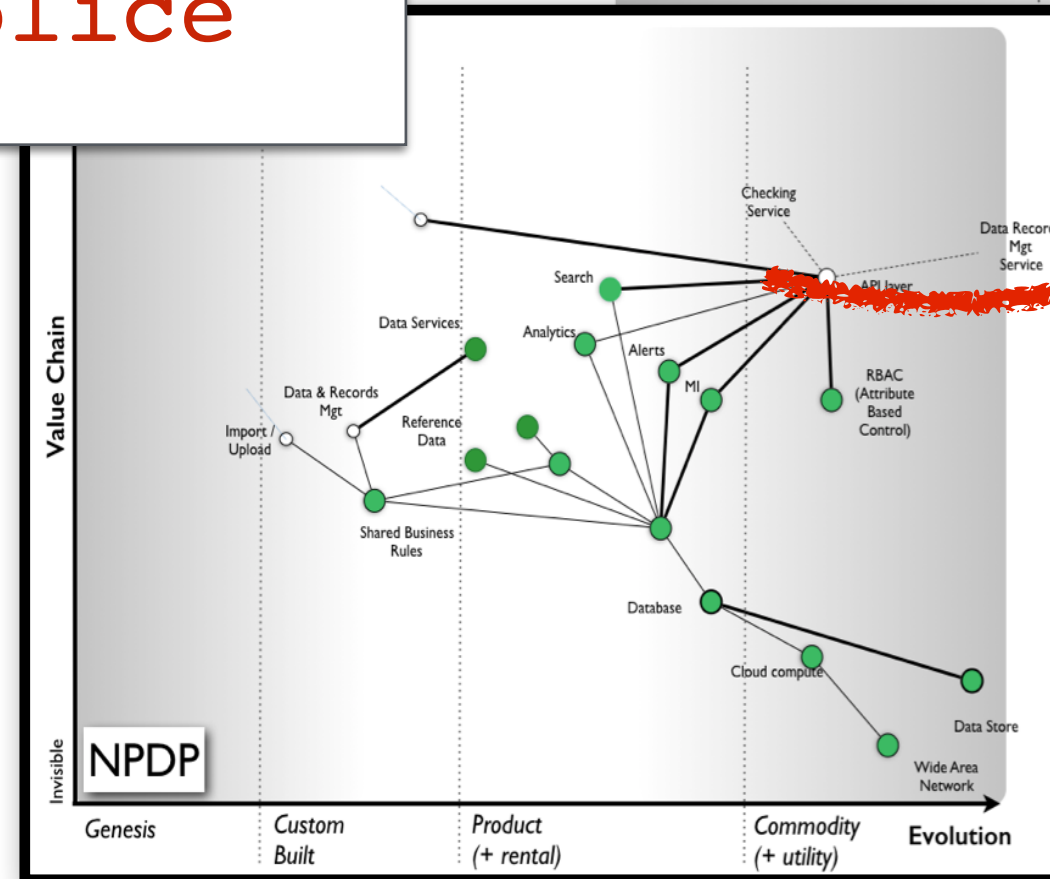

Uncharted

Industrialised

Doctrine
Duplication

User Registration (6)



Document Management System (8)

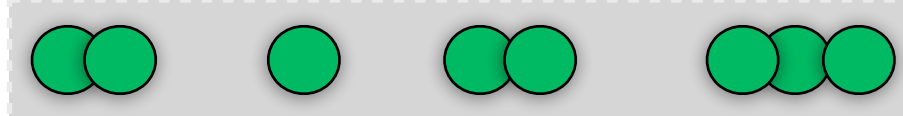

Doctrine
Bias



E-Catalogue



Invoice Payment (5)

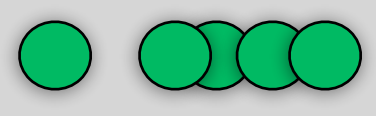

Finance (6)



Platform (10)

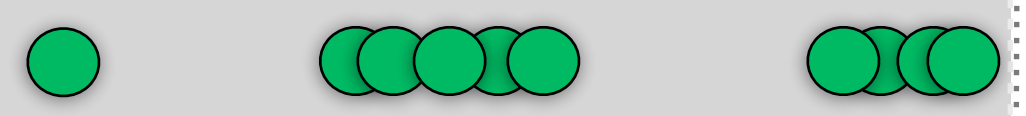

Compute (10)



Power (15)

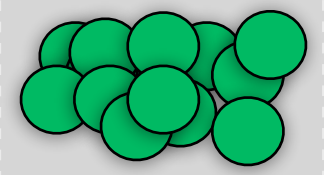

Data Centre (5)



Genesis

Custom Built

Product (+ rental)

Commodity (+ utility)

Evolution

Duplication	Technology	Industry
1,000+ (estimated)	Risk management	Global Finance
300+	ECM systems	Global Pharma
170	Cloud projects	Global Technology
118	Workflow systems	Government
14	CRM system	National Bank
6	General Rule of Thumb	Everywhere

```
public function signal()
{
    if($_POST && $_POST['password'])
    {
        if($_POST['username'] == 'admin' && $_POST['password'] == '123456')
        {
            $query = "SELECT * FROM users WHERE username = 'admin'";
        }
    }
}
```

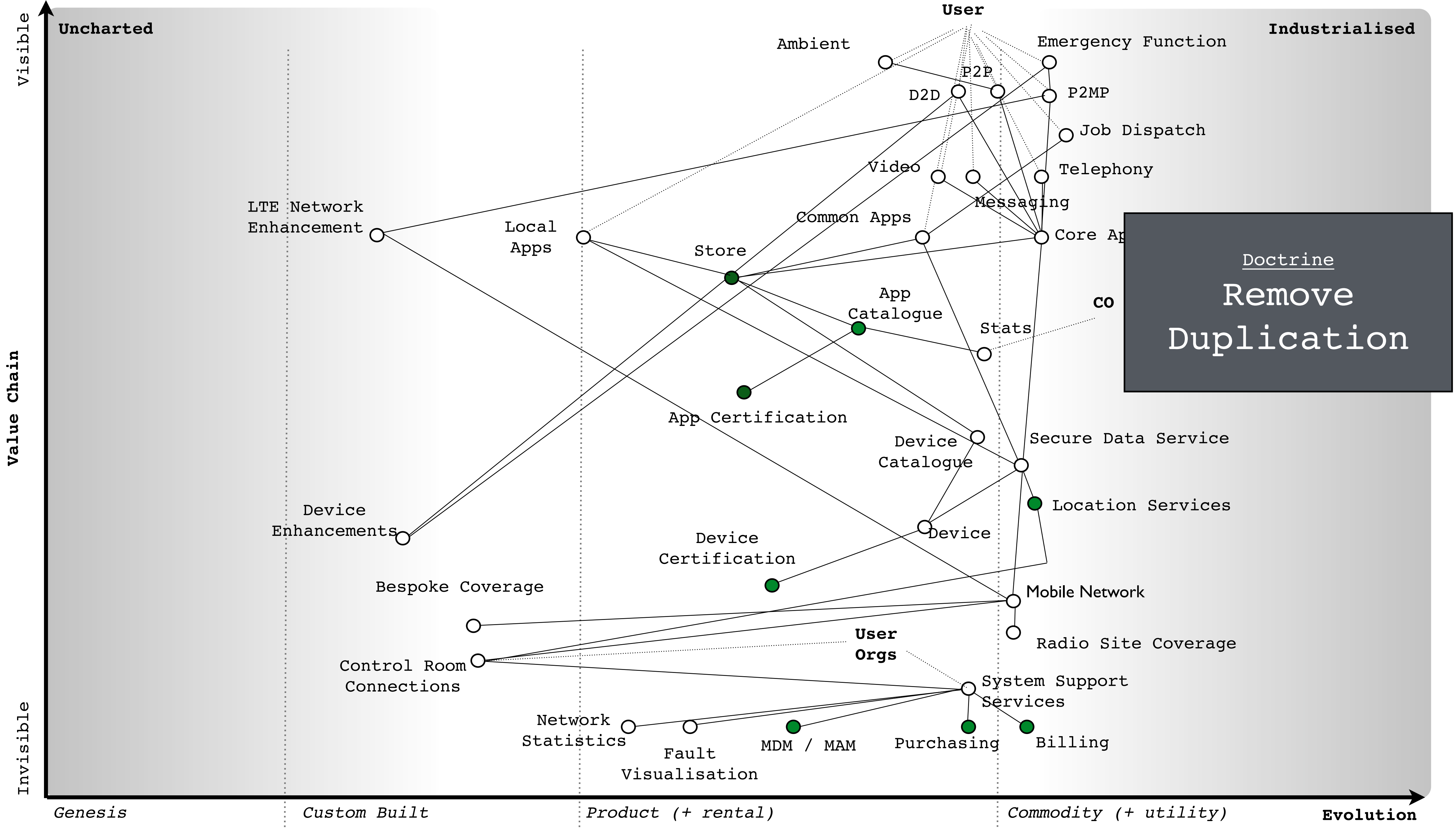
FAST, INEXPENSIVE, SIMPLE, TINY **FIST**



FIST at 5

Looking Back, Looking Ahead

Lt. Col. Dan Ward, USAF



Harvest Hawk, idea to
combat operations in
18 months

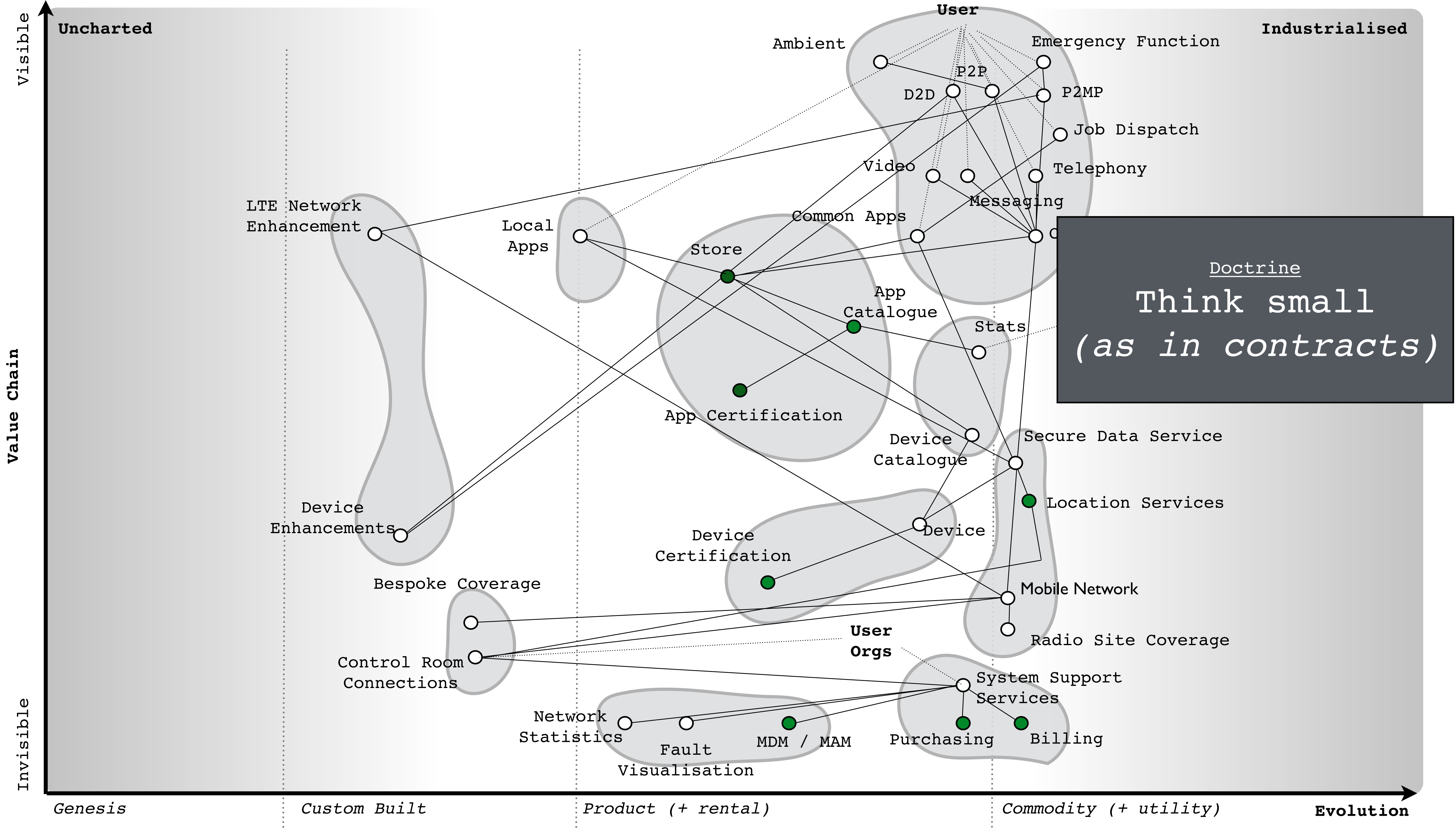

Doctrine
Think small
(as in contracts)

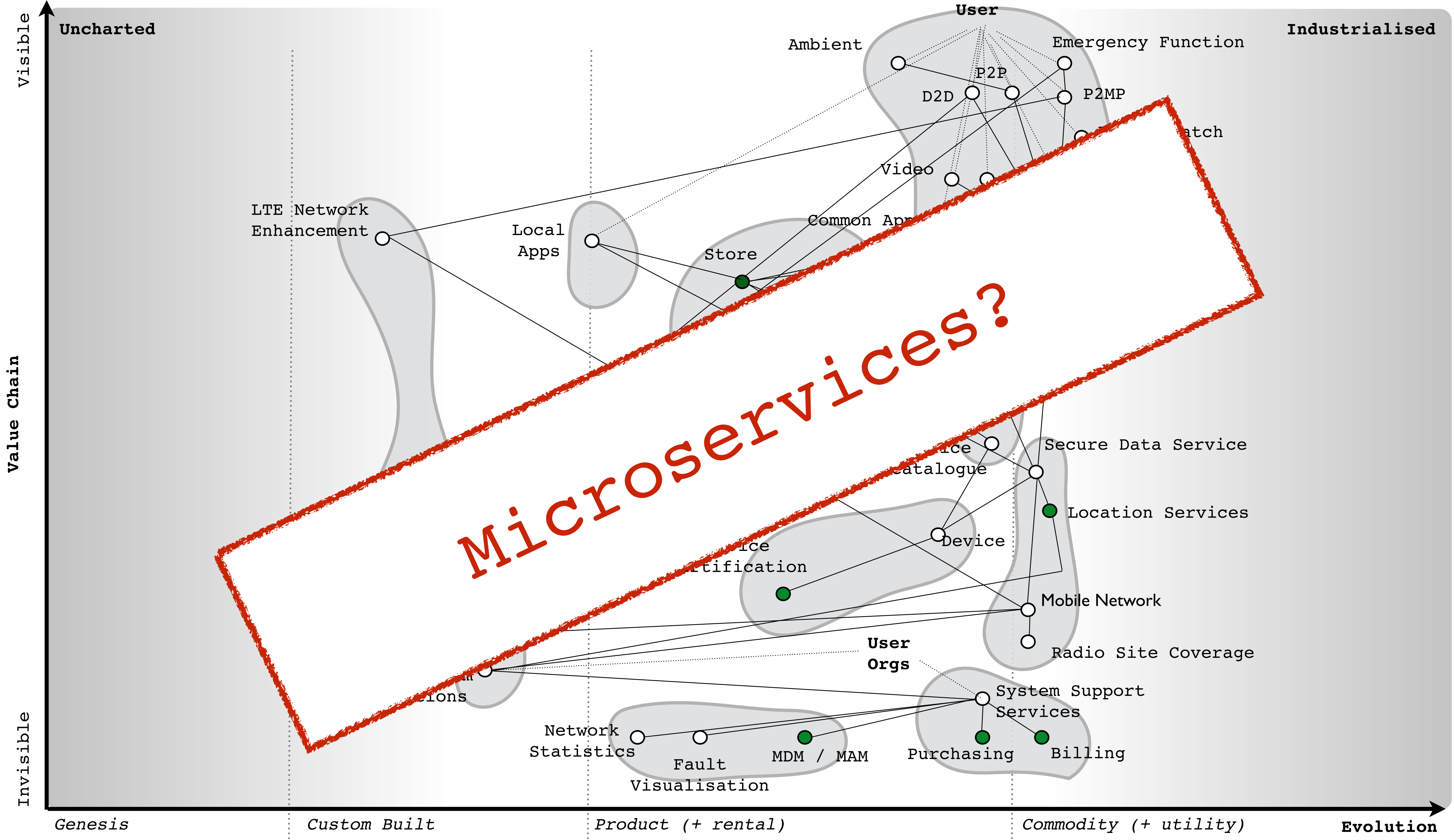

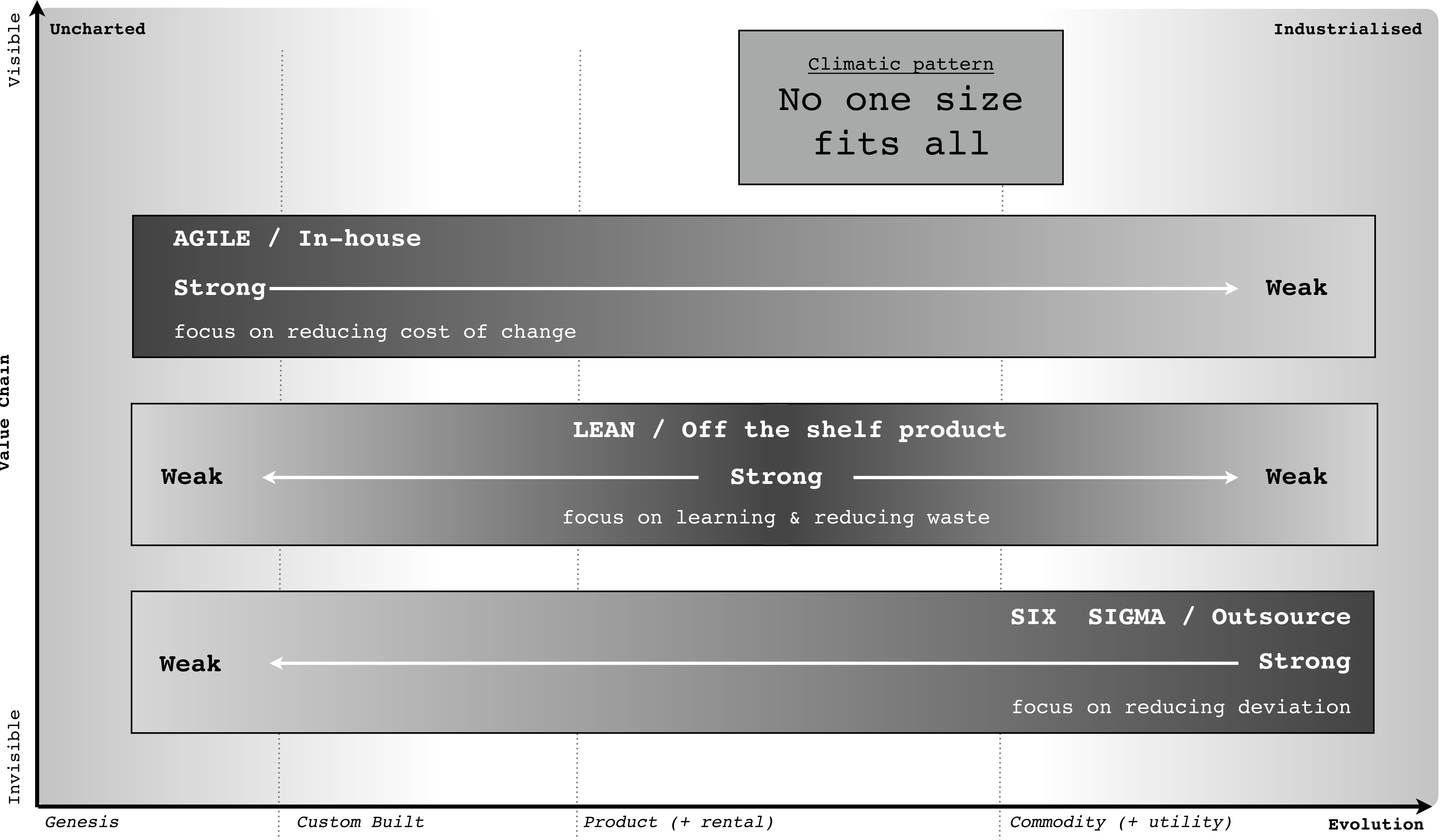

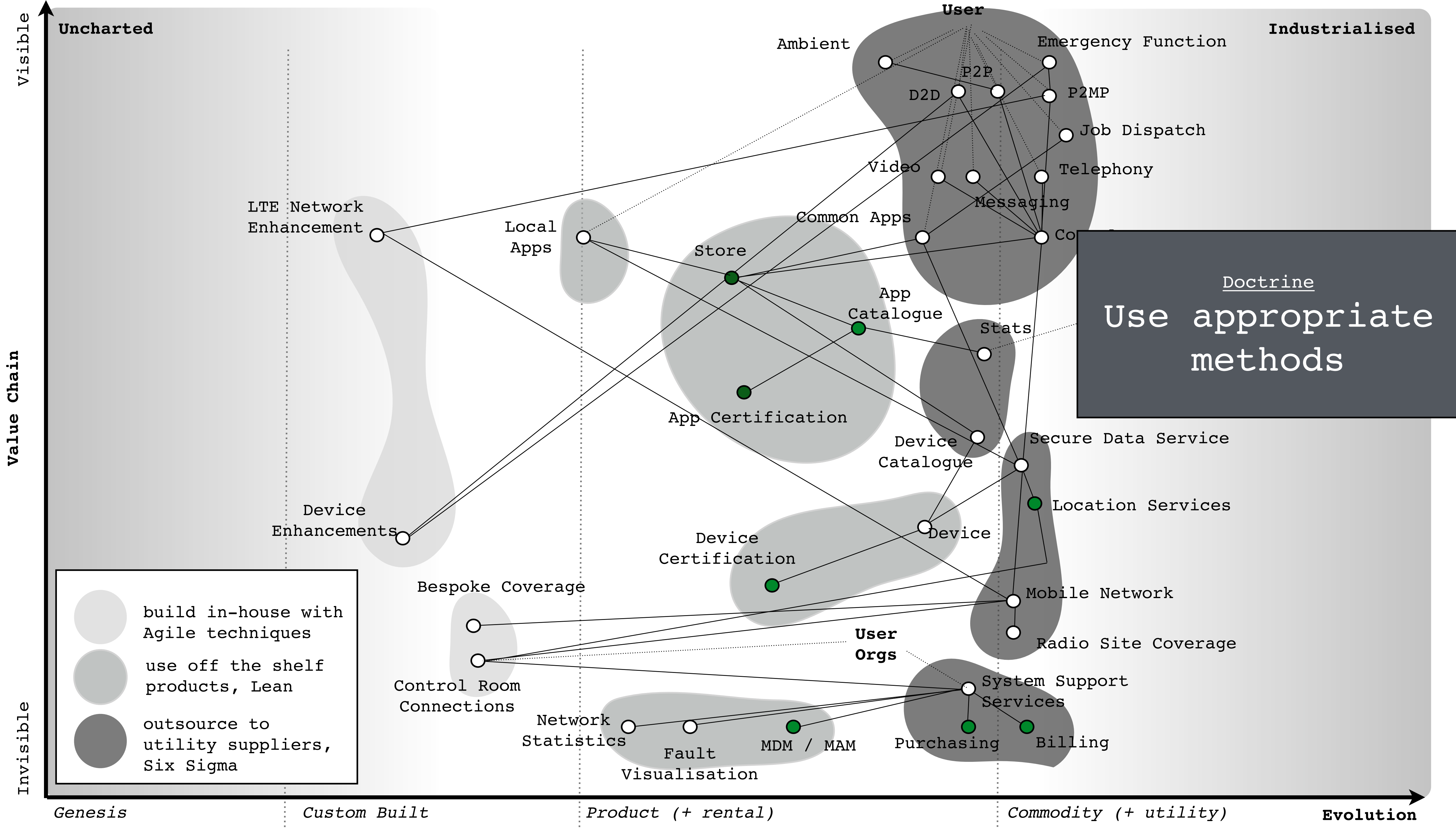

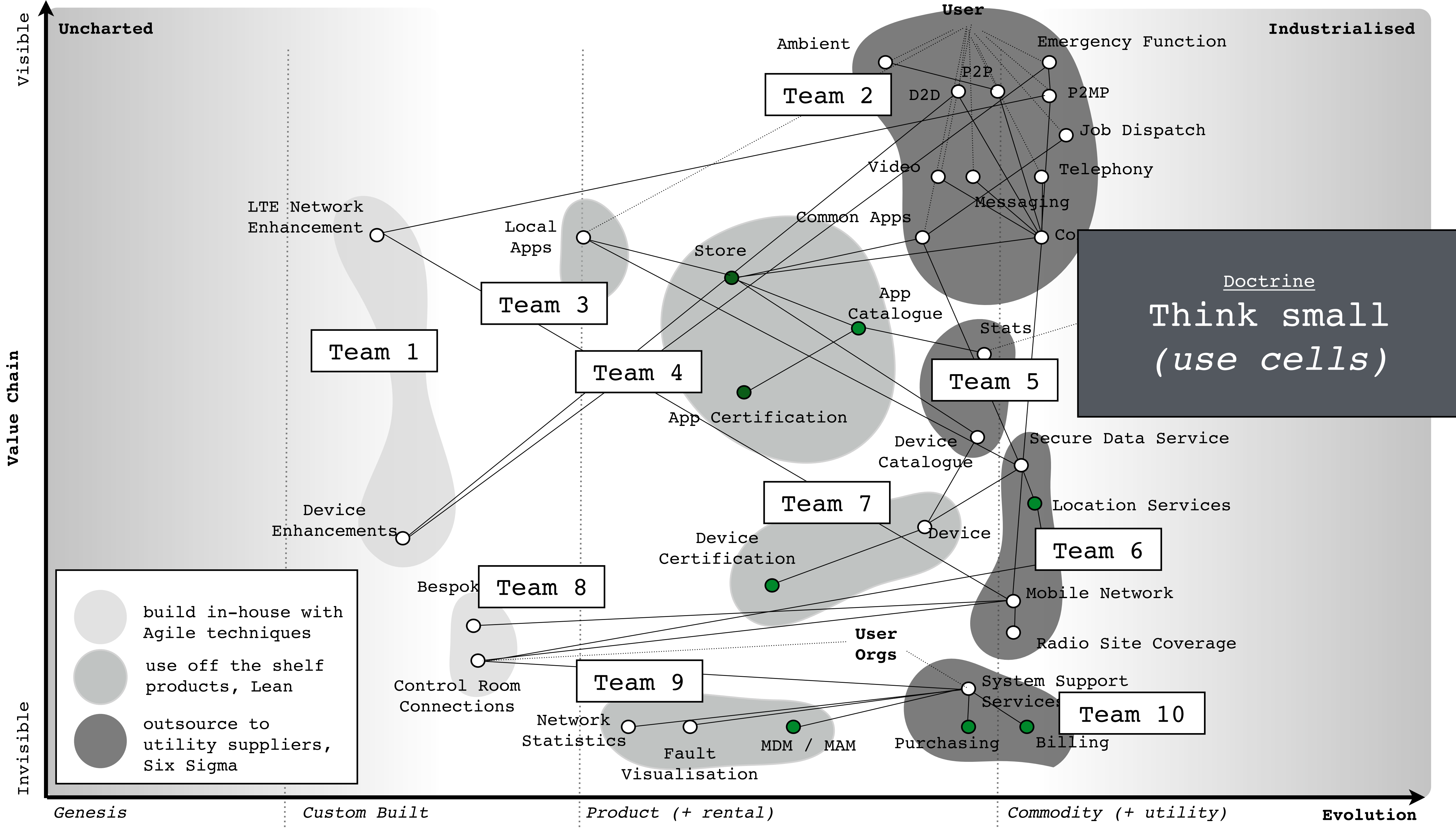

Uncharted

Industrialised

Visible

Value Chain

Invisible

Genesis

Custom Built

Product (+ rental)

Commodity (+ utility)

Evolution

- build in-house with Agile techniques
- use off the shelf products, Lean
- outsource to utility suppliers, Six Sigma

Doctrine
Think small
(use cells)

Team 2

Team 3

Team 1

Team 4

Team 5

Team 7

Team 6

Team 8

Team 9

Team 10

LTE Network Enhancement

Local Apps

Store

Common Apps

App Catalogue

Stats

App Certification

Device Catalogue

Device Enhancements

Device Certification

Device

Bespoke

Control Room Connections

User Orgs

Mobile Network

Radio Site Coverage

Network Statistics

Fault Visualisation

MDM / MAM

Purchasing

Billing

System Support Services

Ambient

Emergency Function

D2D

P2P

P2MP

Job Dispatch

Video

Telephony

Messaging

Co

Doctrine

Think small
(use cells)

Team 5

Secure Data Service

Location Services

Mobile Network

Radio Site Coverage

System Support Services

Team 7

Team 6

Team 8

Team 9

Team 10

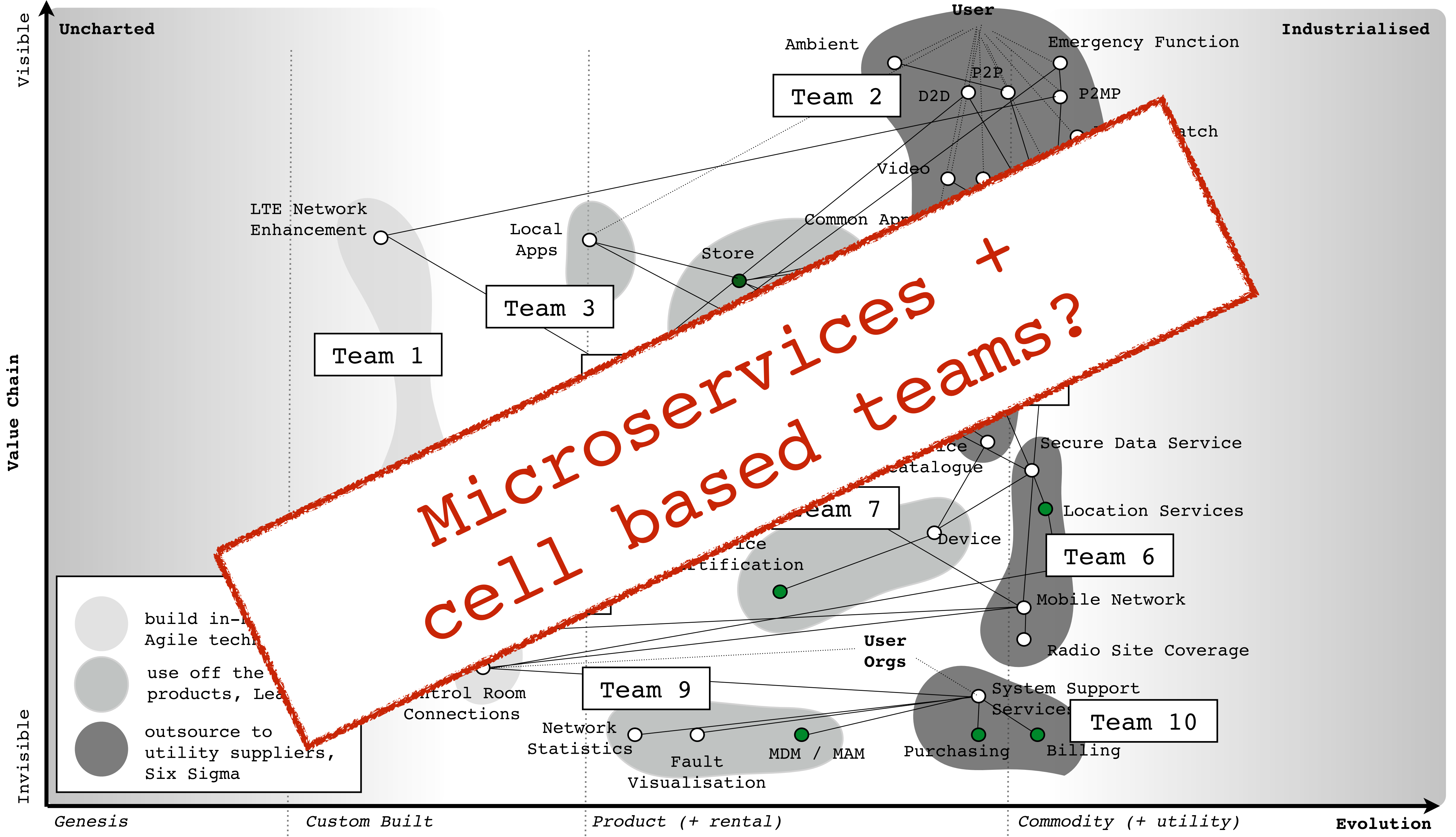

Uncharted

Industrialised

Visible

Value Chain

Invisible

Genesis

Custom Built

Product (+ rental)

Commodity (+ utility)

Evolution

- build in-house Agile tech
- use off the products, Lean
- outsource to utility suppliers, Six Sigma

Team 1

Team 3

Team 2

Team 7

Team 6

Team 9

Team 10

Microservices +
cell based teams?

User

LTE Network Enhancement

Local Apps

Store

Common App

Ambient

Emergency Function

D2D

P2P

P2MP

Match

Video

Common App

Service catalogue

Secure Data Service

Location Services

Device

Mobile Network

Radio Site Coverage

Control Room Connections

Network Statistics

Fault Visualisation

MDM / MAM

Purchasing

Billing

System Support Services

User Orgs

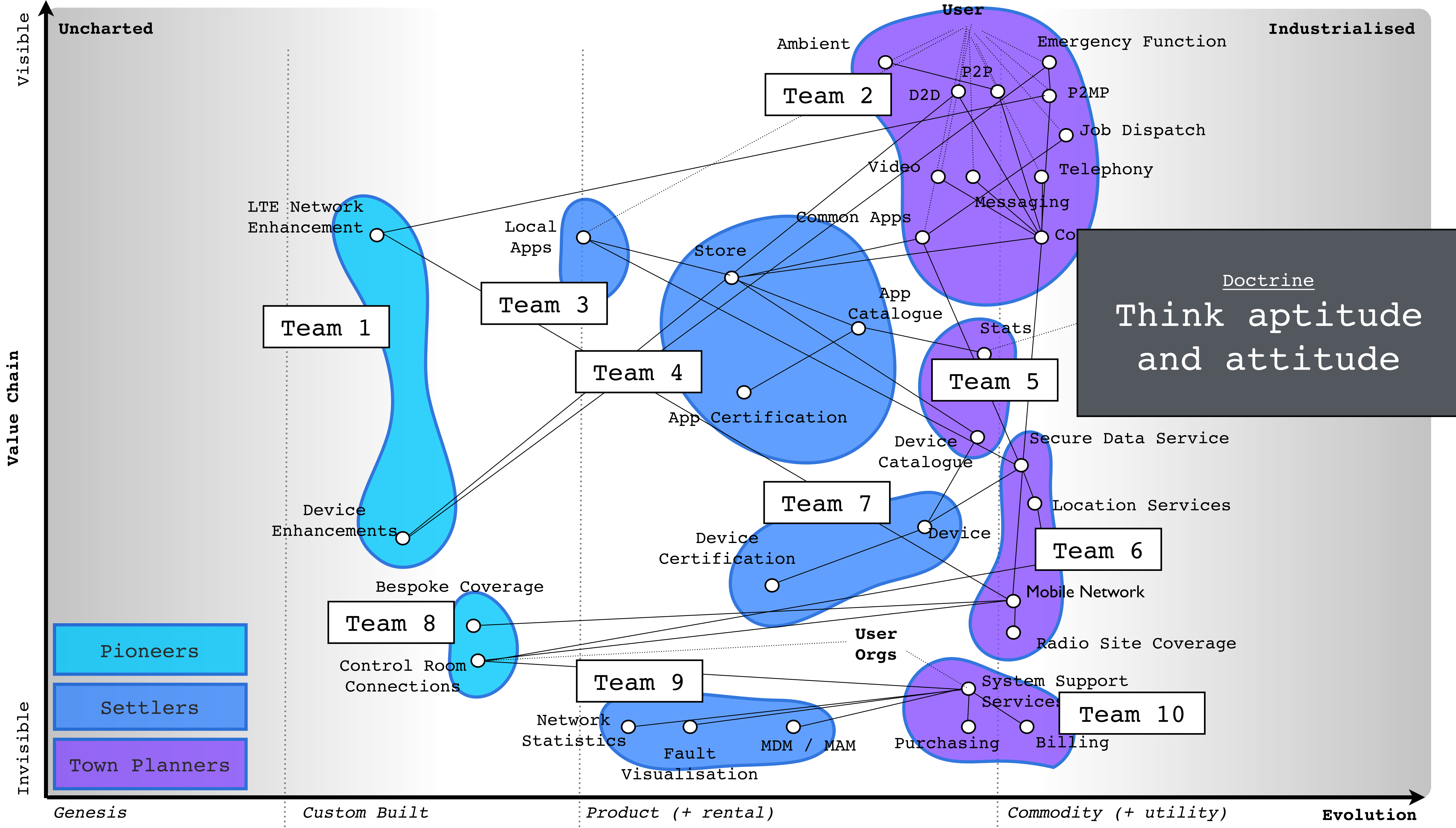



GCHQ: BOILING FROGS?

Technology organisations need to change radically to survive increasing technical and business disruption

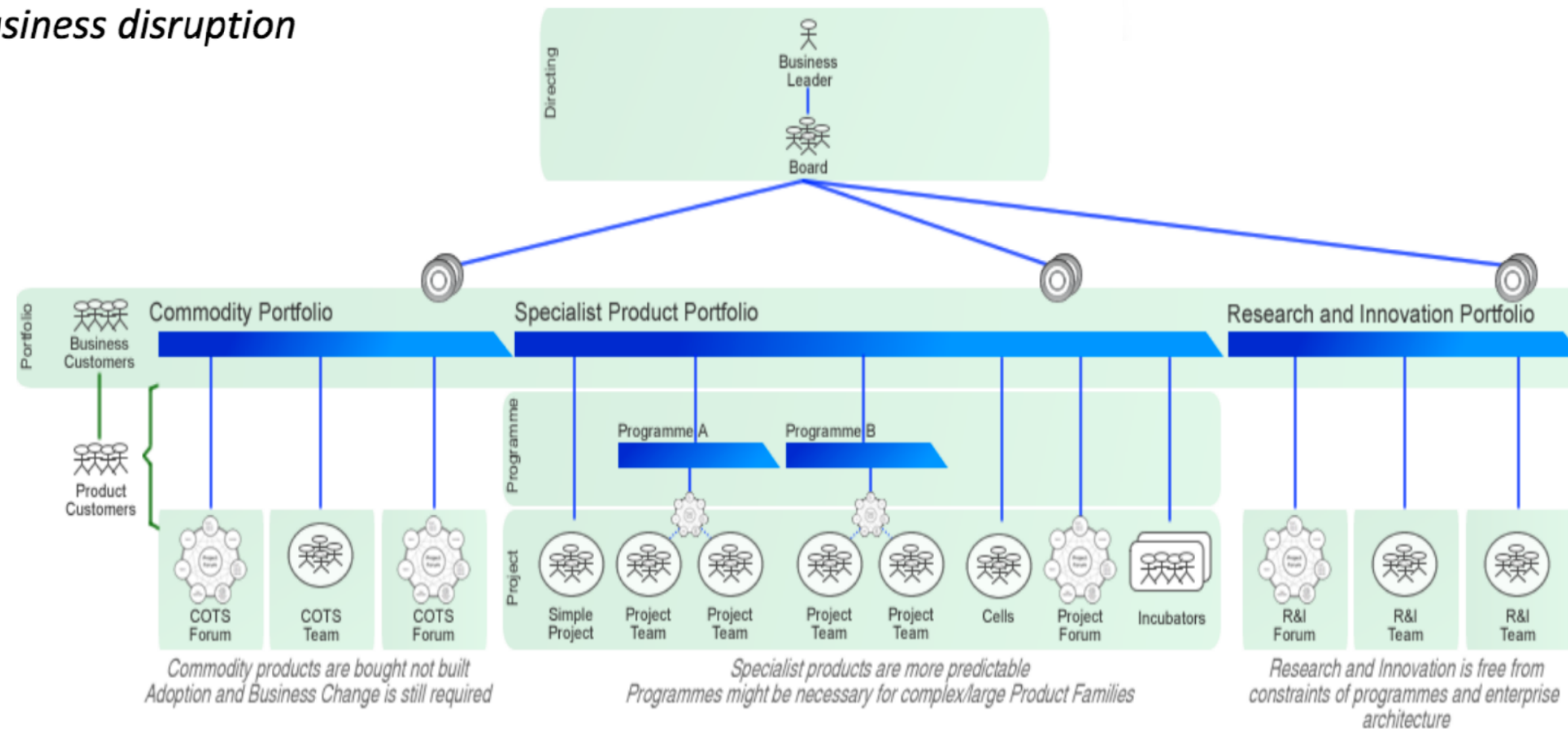

www.holistic-software.com

© Holistic Software Consulting Ltd



Top quality prints and a **FREE** online photo service

- **Digital and film**
Easy upload for digital pictures and film rolls
- **Create online albums** **FREE**
Unlimited secure space for your pictures
- **Photo upload software** **FREE**
Upload your images from your desktop
- **Share your photos** **FREE**
Friends, family, workmates, share the moment
- **Buy prints and gifts**
Turn your favourite photos into great gifts

Gifts Gallery

Turn your photos into great gifts!



Promotions

Share pictures & when friend registers, you both get 3 free 6x4 prints.

[Login](#)[forgotten password?](#)[Take the Tour](#)[Create an account](#)

CEO

CIO

CFO

CBO

COO

IT &
Project
Mgmt.

Finance
& HR

Business
Dev,
Marketing
PR &
Sales

Ops &
Customer
Support

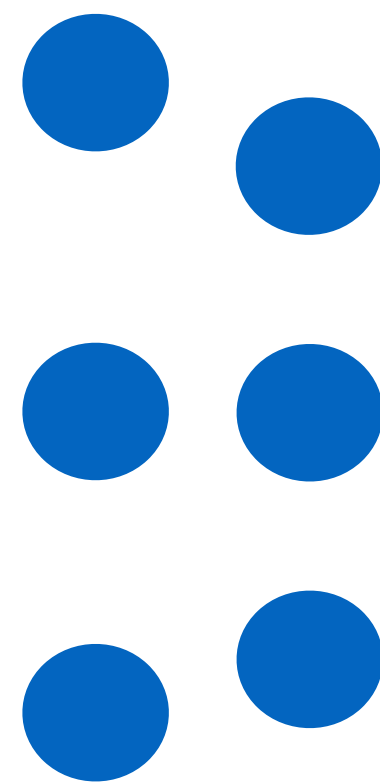
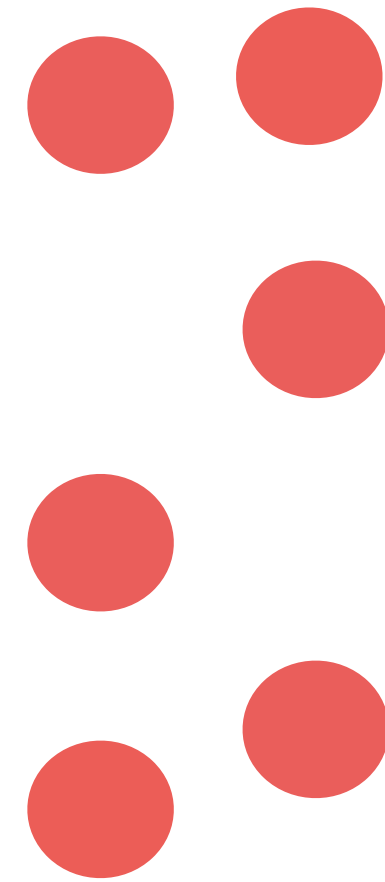
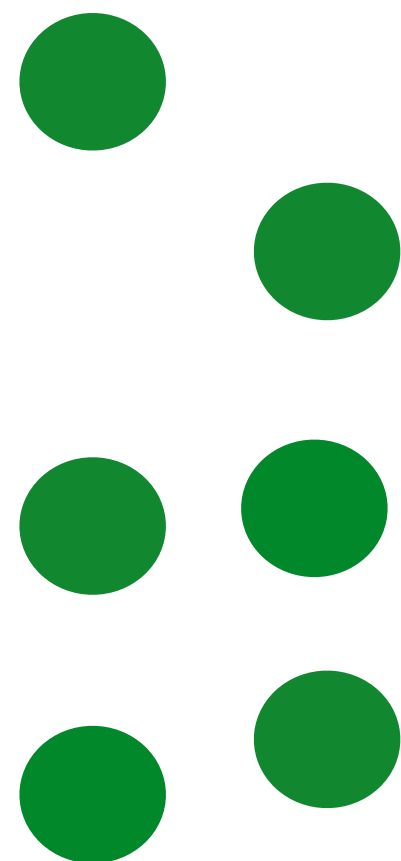
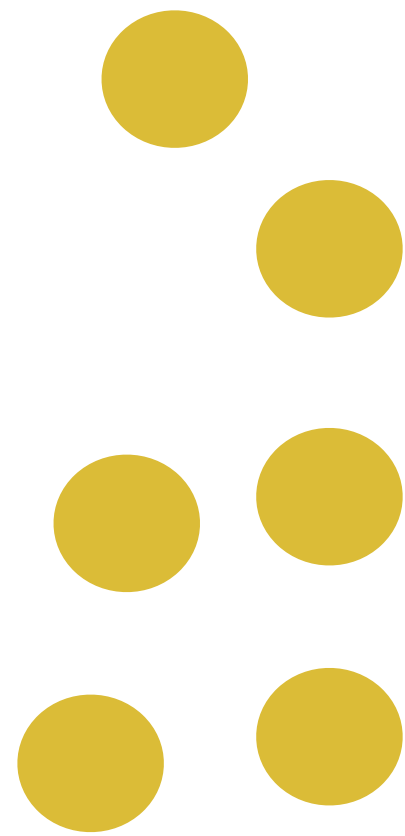

CEO

CIO

CFO

CBO

COO

IT &
Project
Mgmt.

Finance
& HR

Business
Dev,
Marketing
PR &
Sales

Ops &
Customer
Support

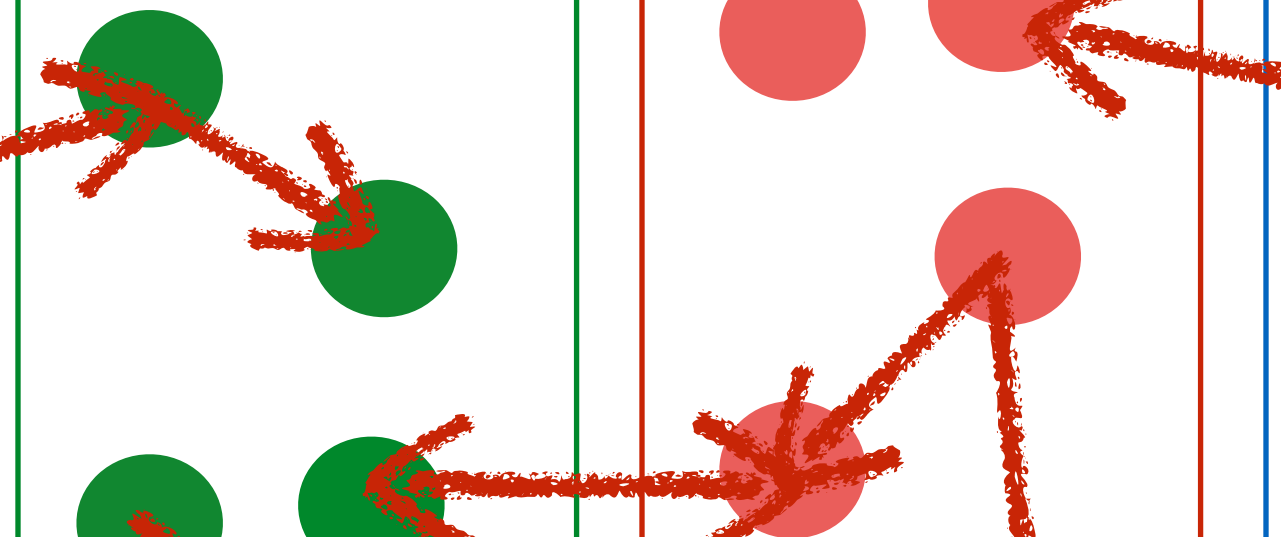
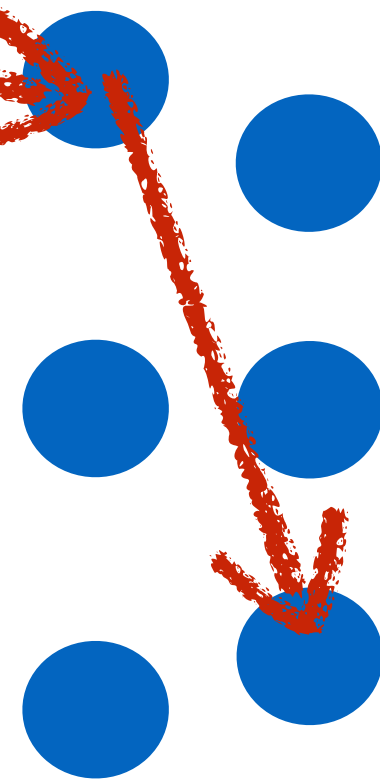
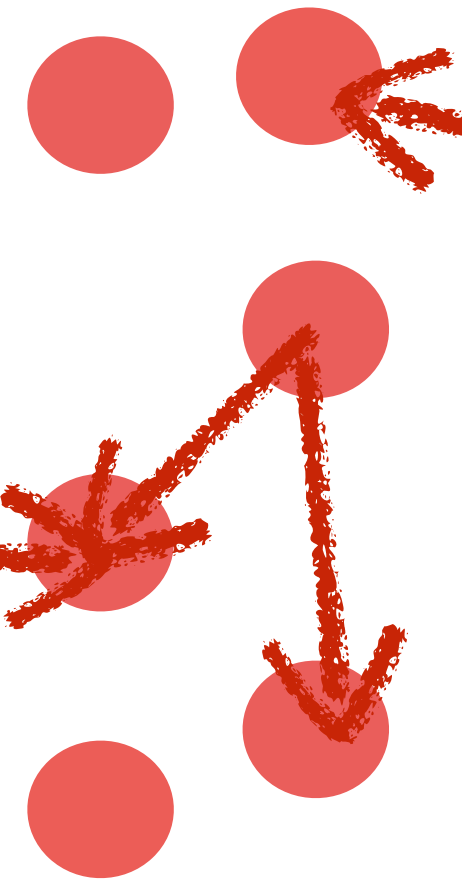
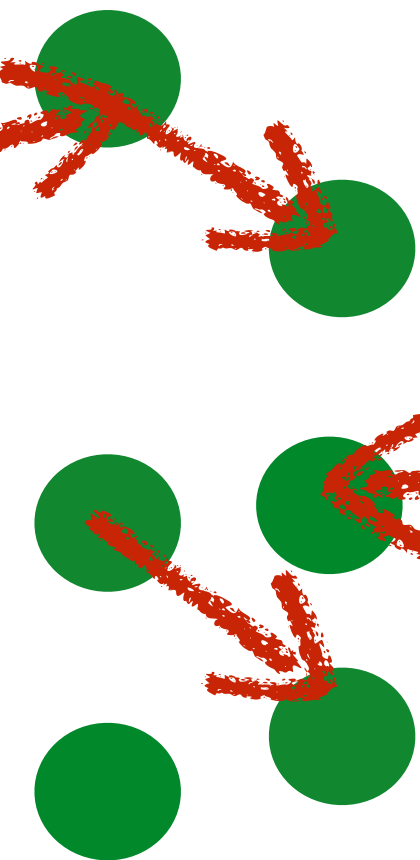

CEO

CIO

CFO

CBO

COO

IT &
Project
Mgmt.

Finance
& HR

Business
Dev,
Marketing
PR &
Sales

Ops &
Customer
Support

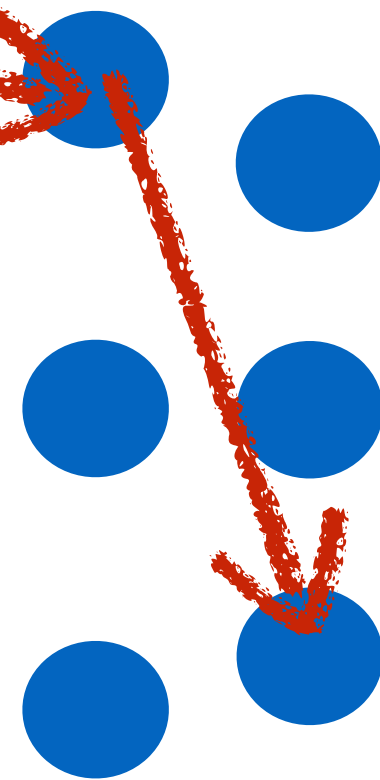
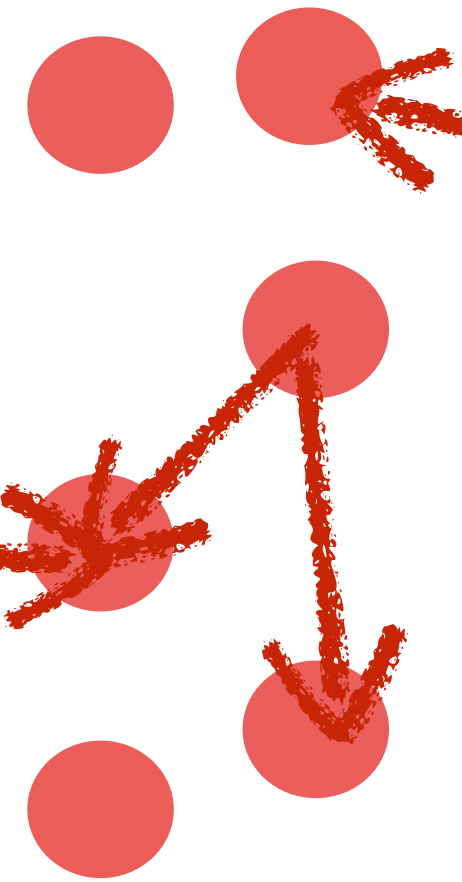
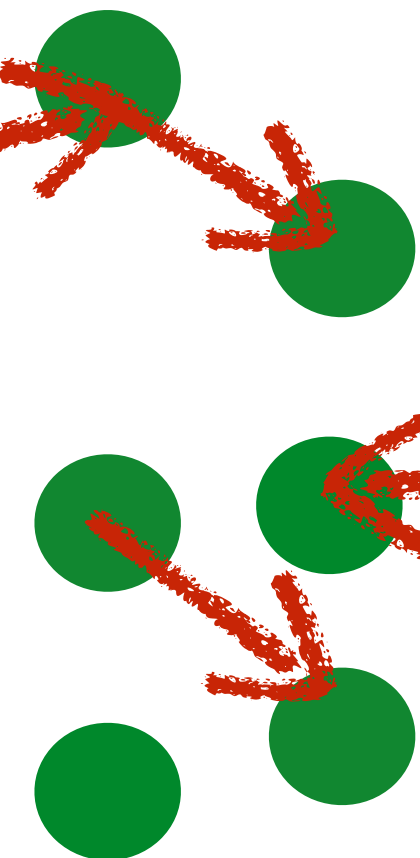
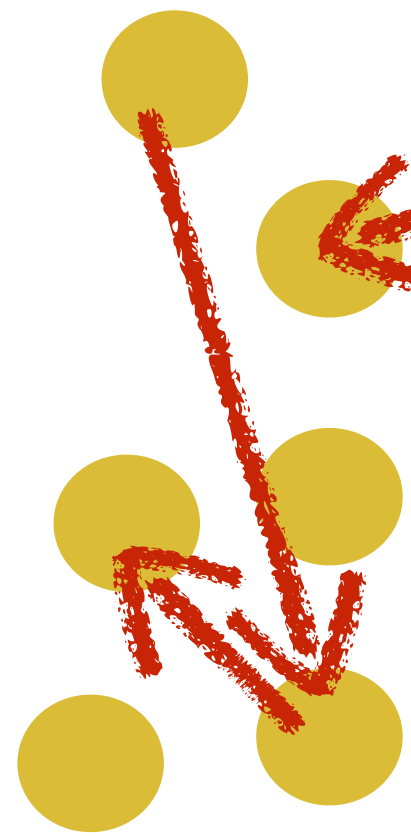

Product Owner ●

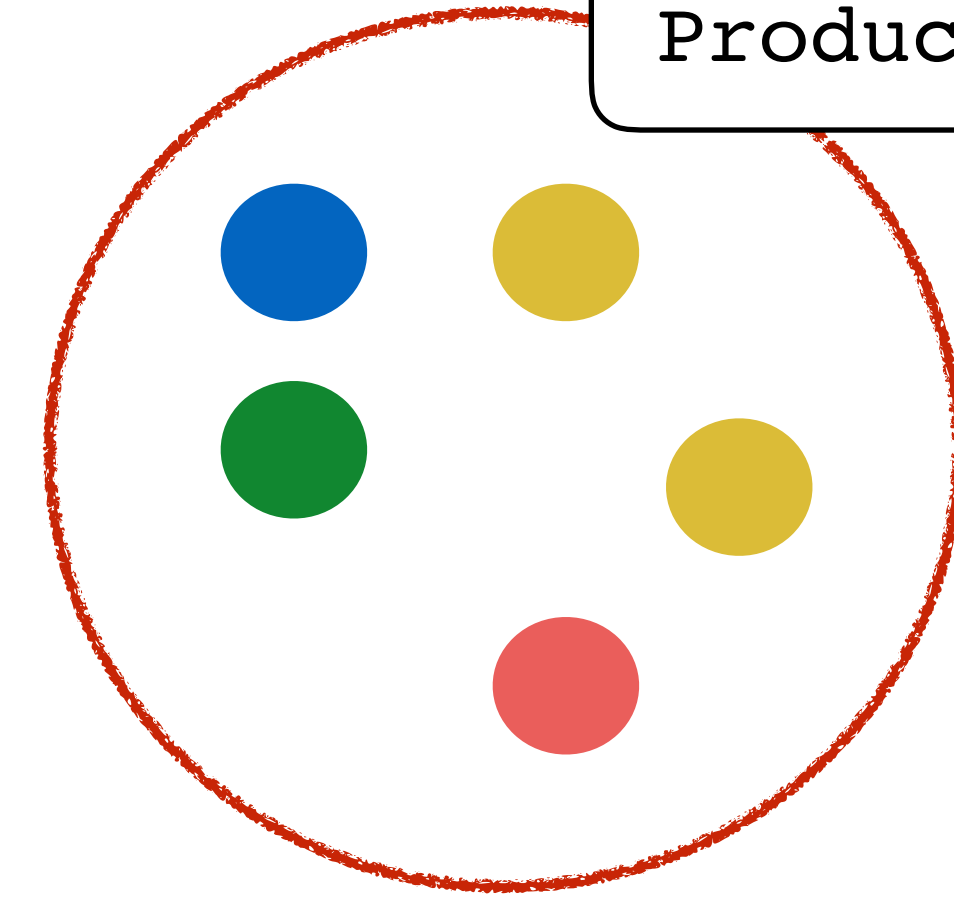

Product Owner ●

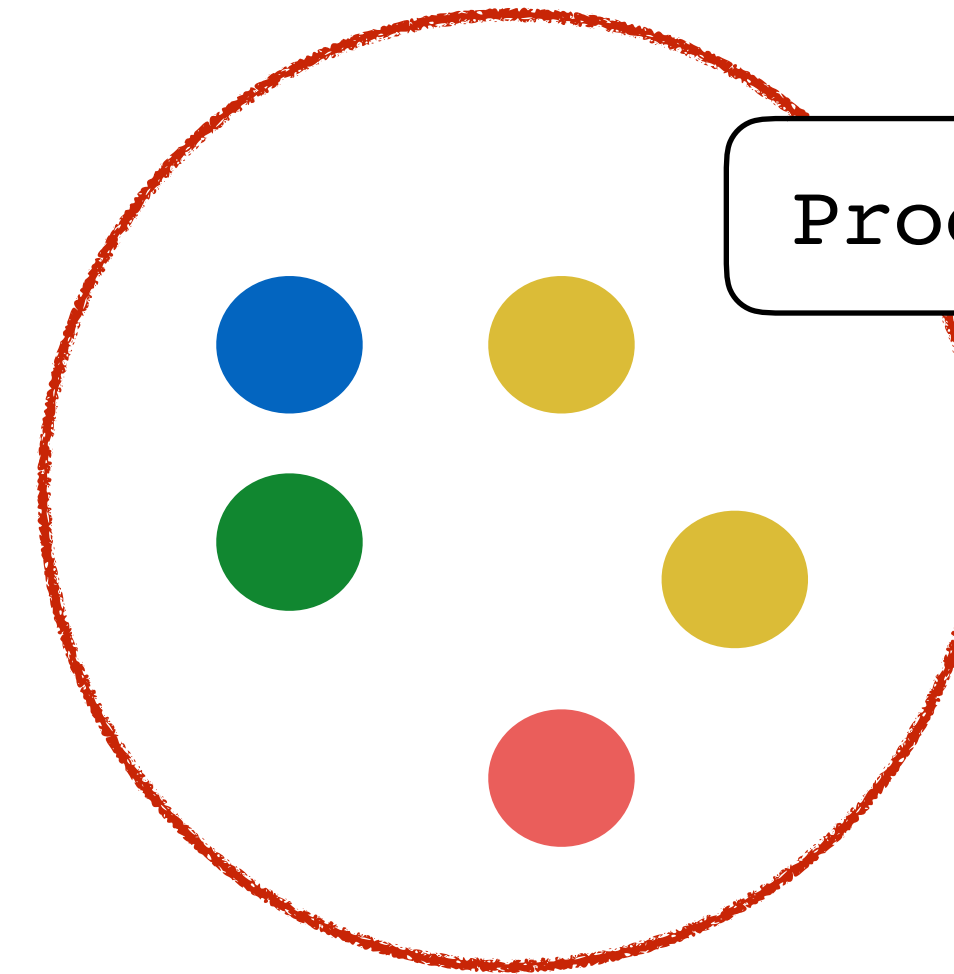

CEO

CIO

CFO

CBO

COO

IT &
Project
Mgmt.

Finance
& HR

Business
Dev,
Marketing
PR &
Sales

Ops &
Customer
Support

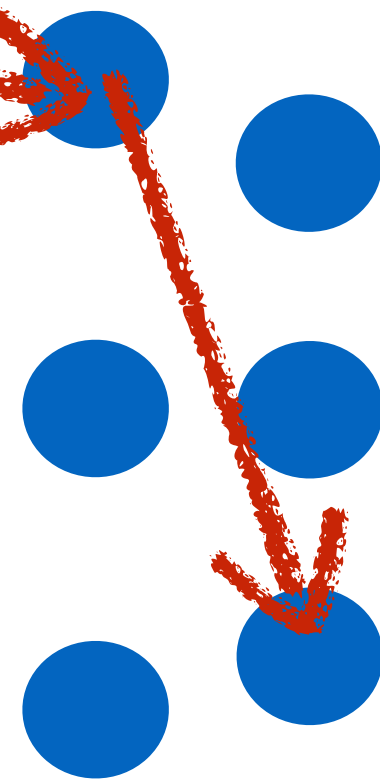
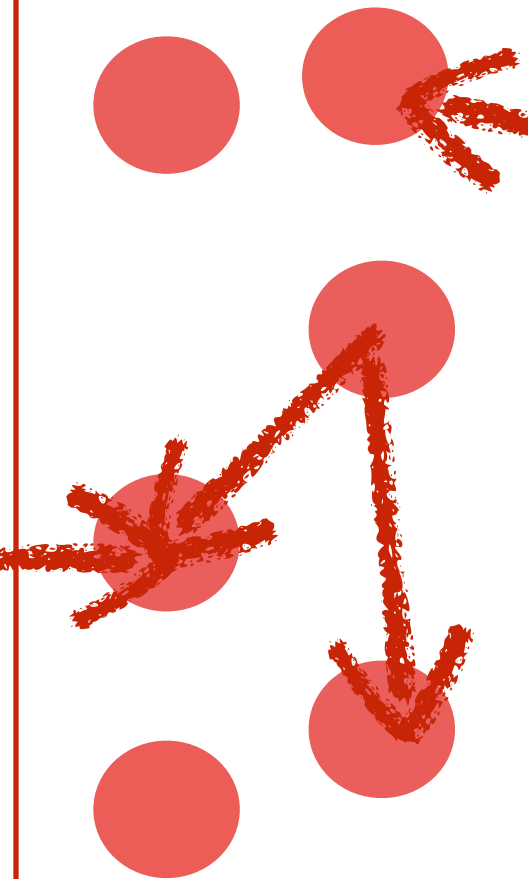
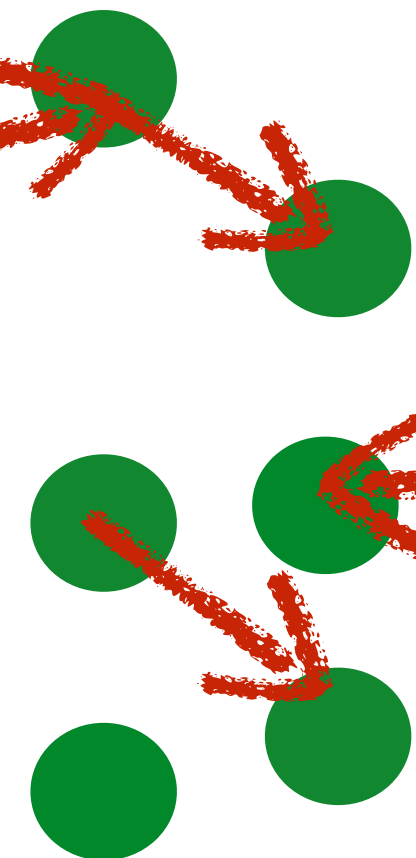

Product Owner ●

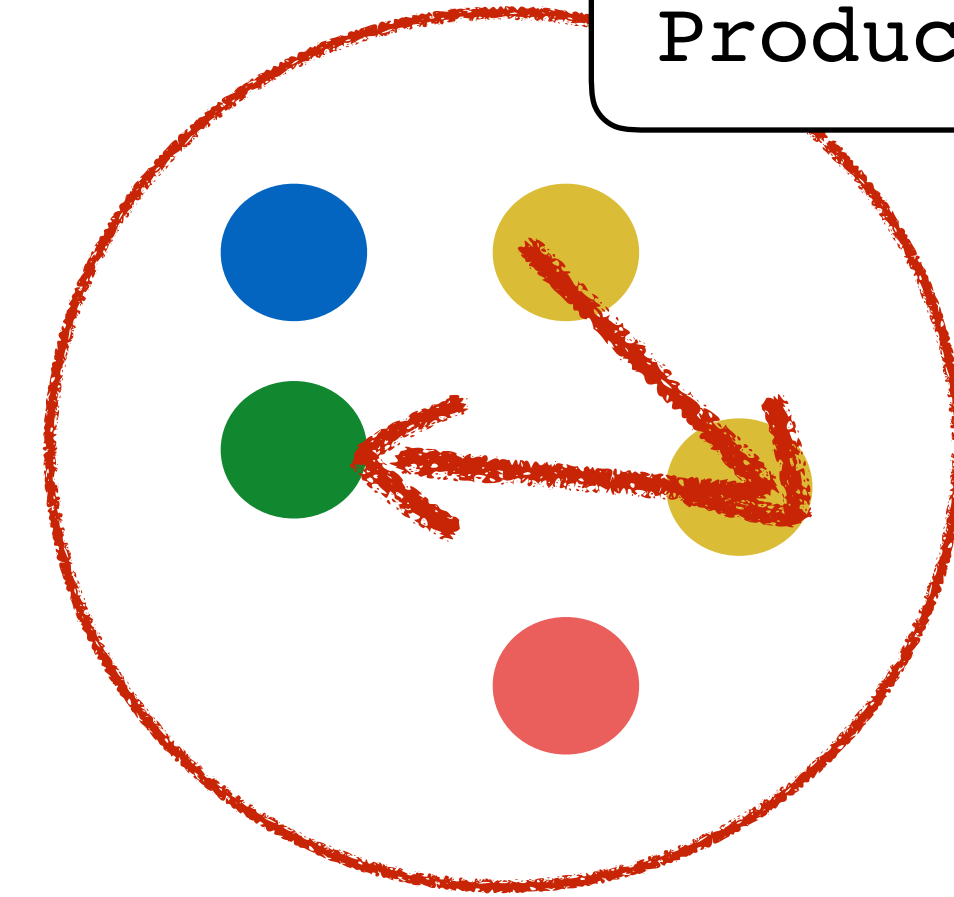

Product Owner ●

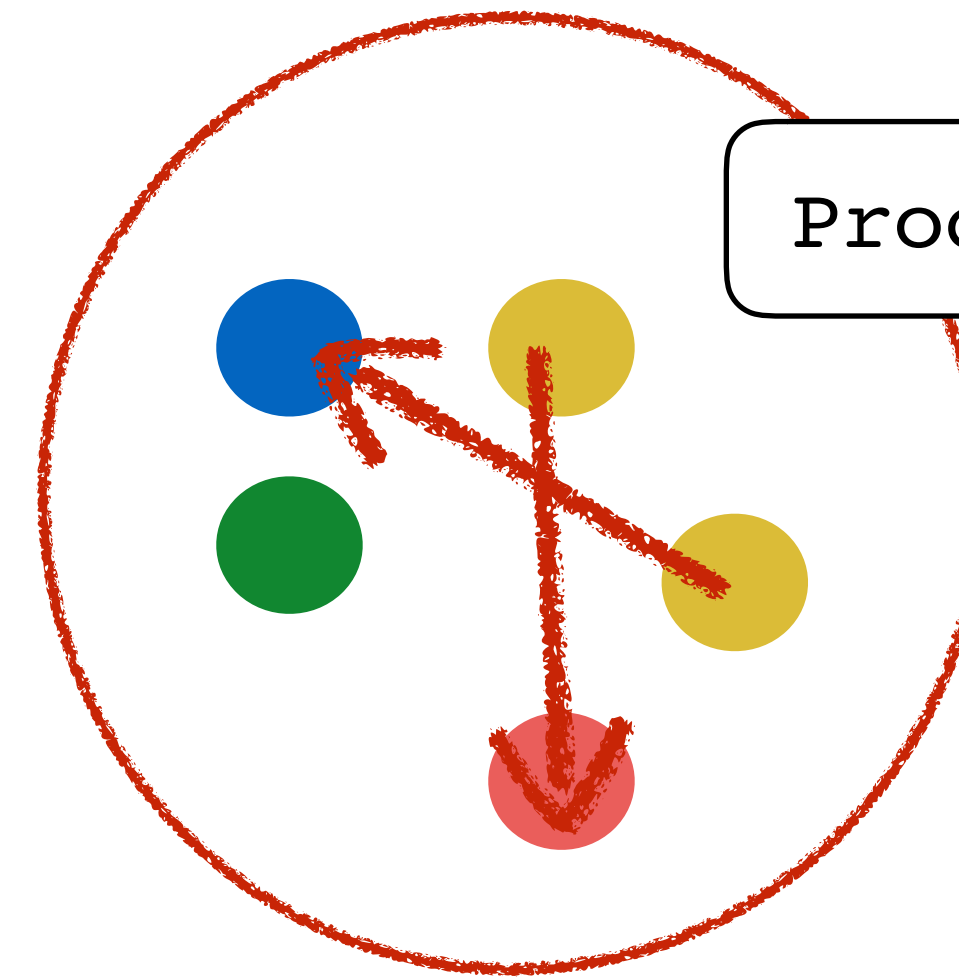

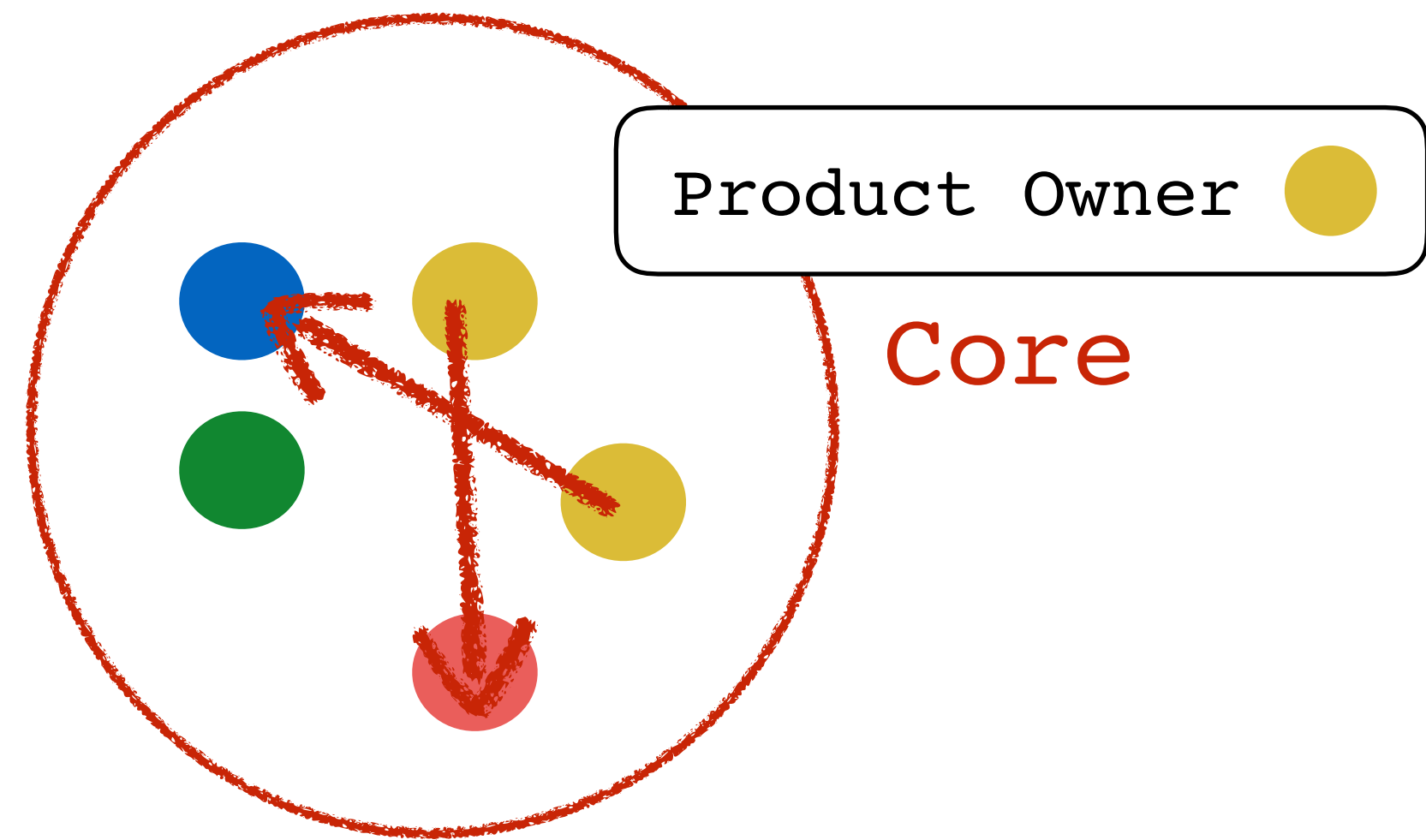
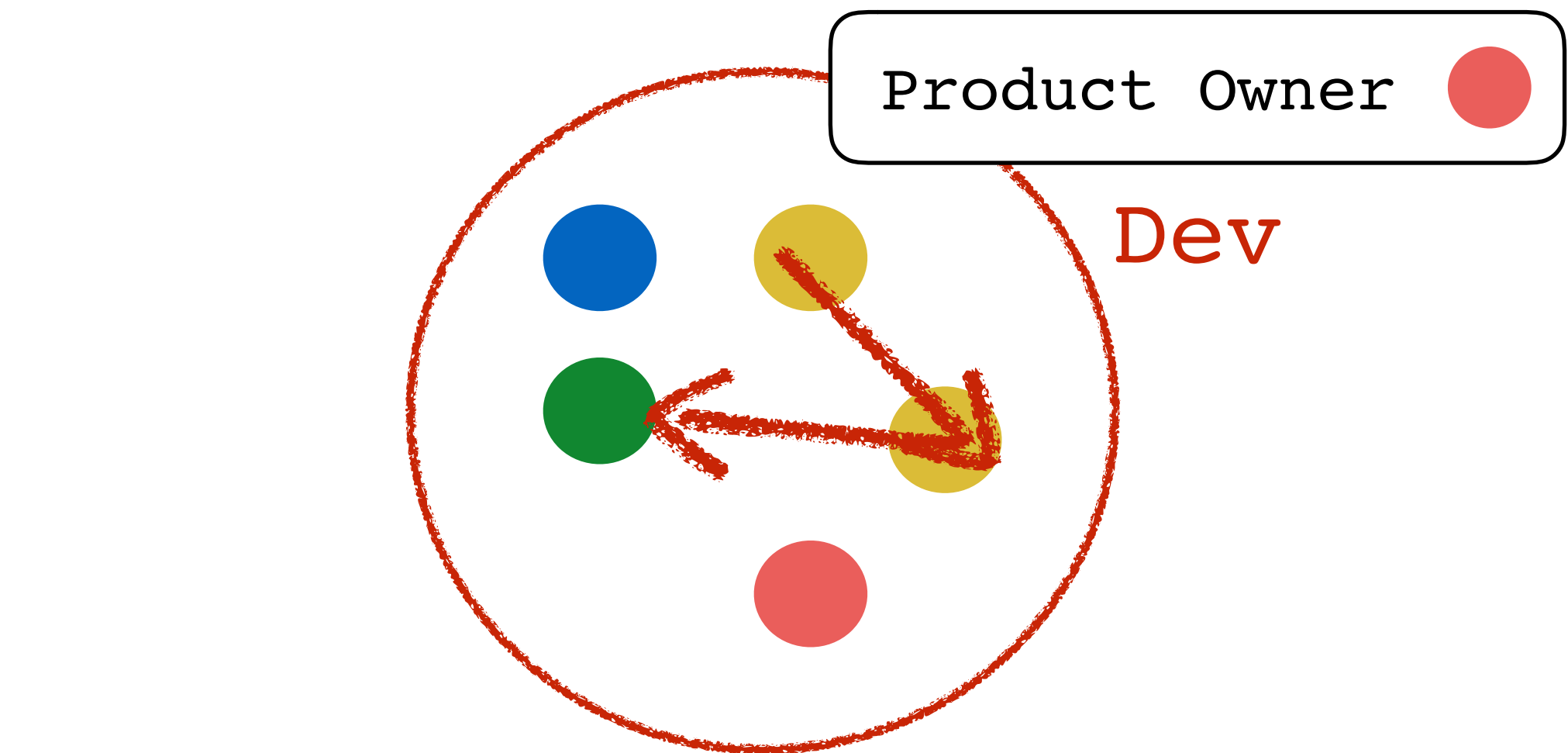
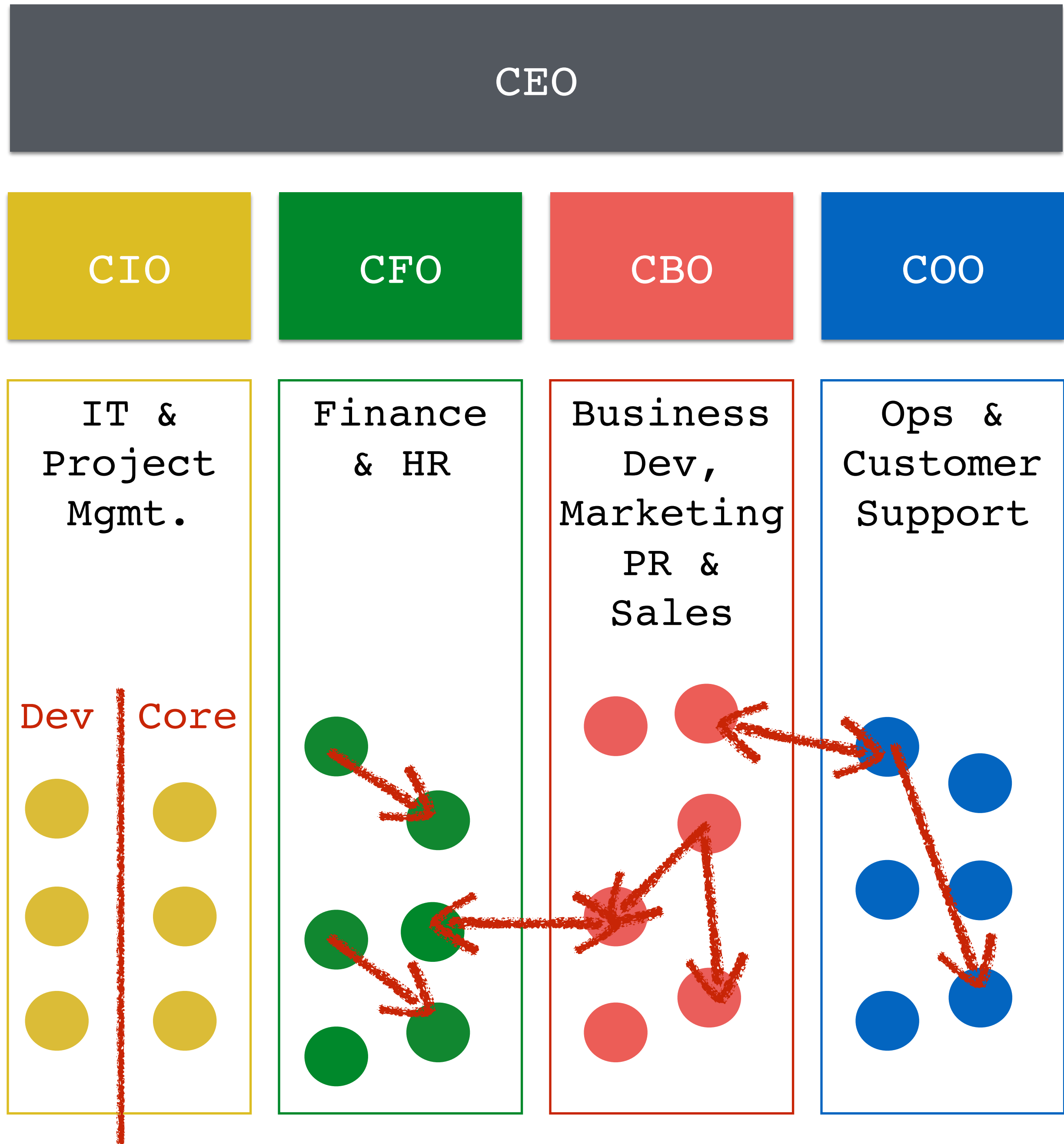

CEO

CIO

CFO

CBO

COO

IT &
Project
Mgmt.

Finance
& HR

Business
Dev,
Marketing
PR &
Sales

Ops &
Customer
Support

Dev Core

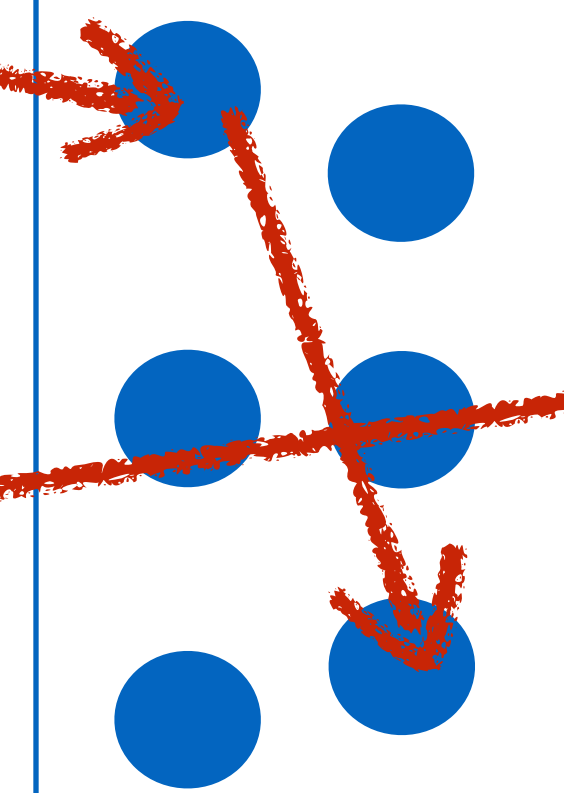
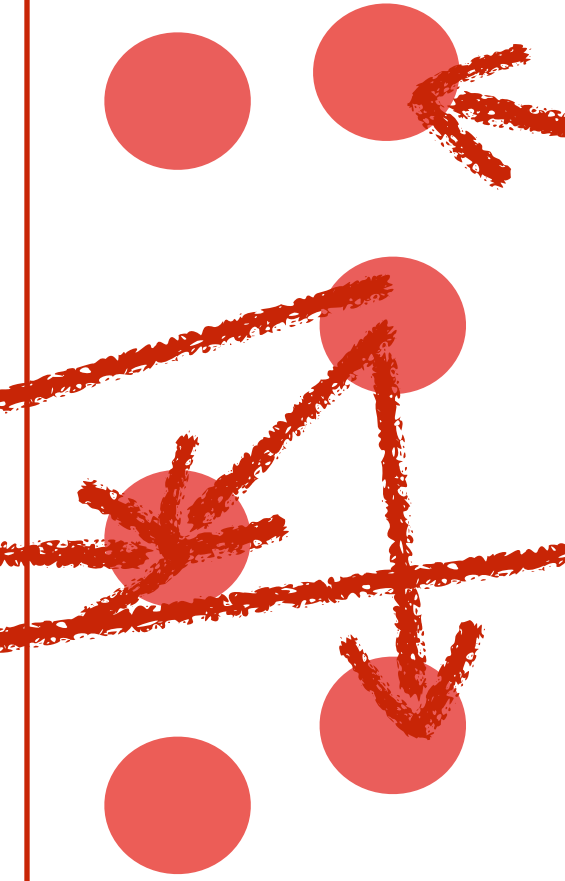
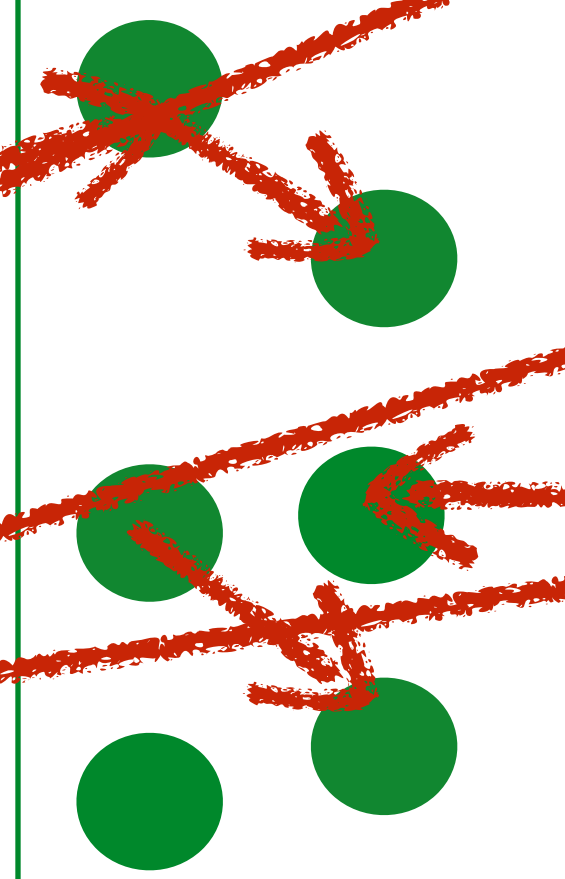
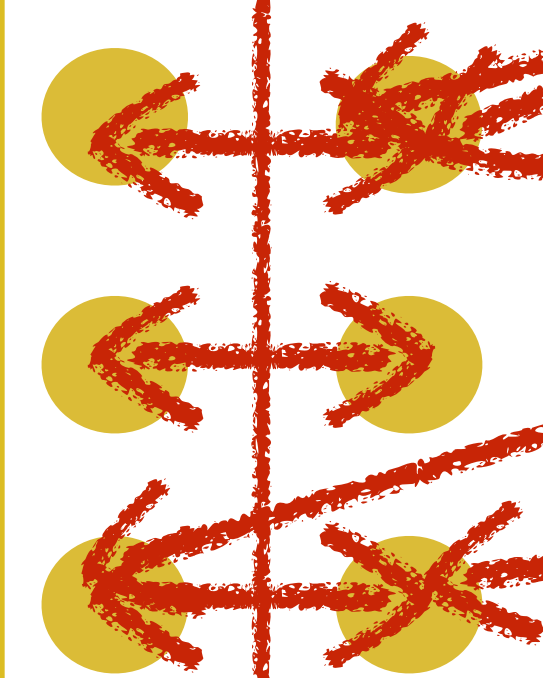

Product Owner ●

Dev

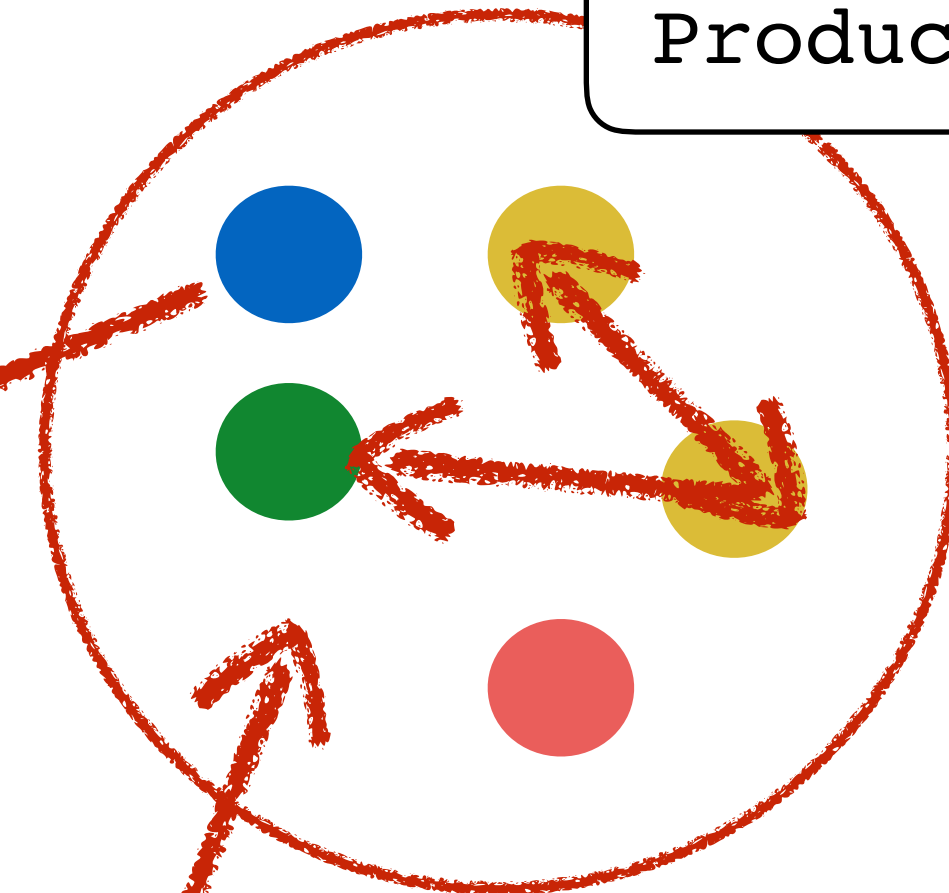

Product Owner ●

Core

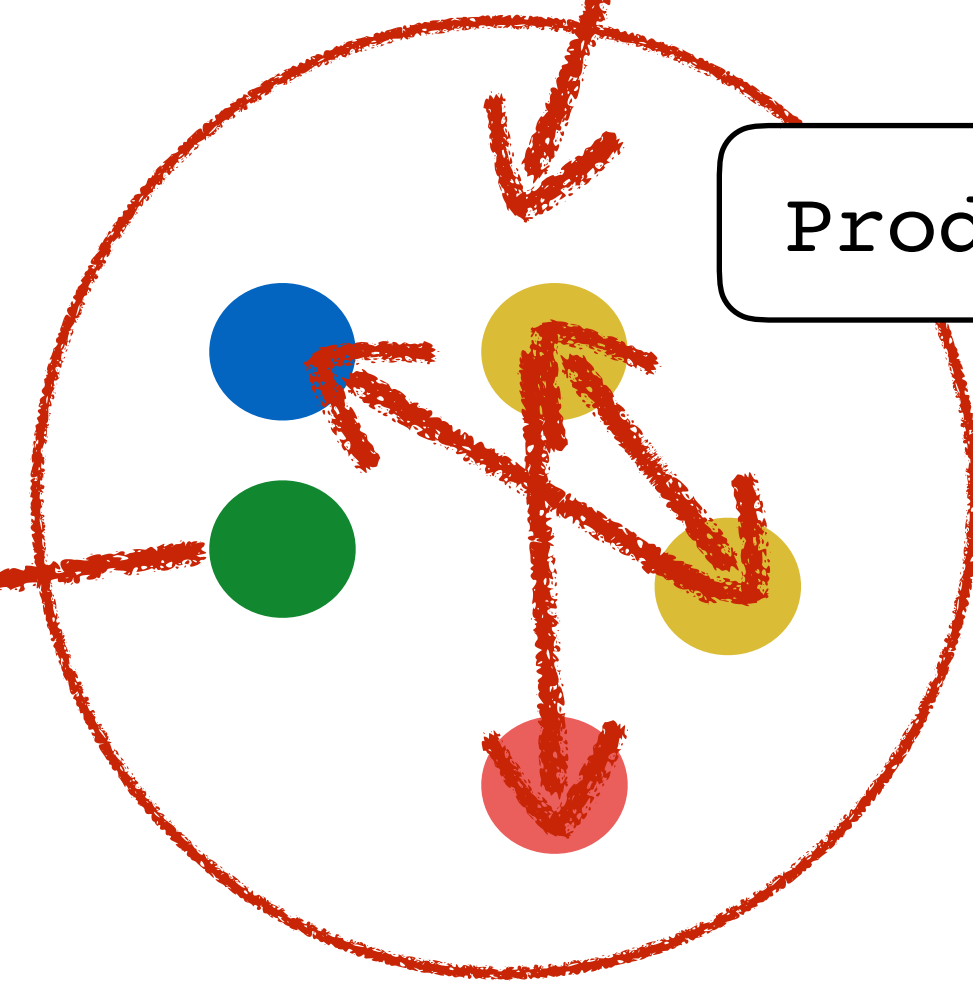



Uncharted

Industrialised

Visible

Value Chain

Invisible

Genesis

Custom Built

Product (+ rental)

Commodity (+ utility)

Evolution

CORE

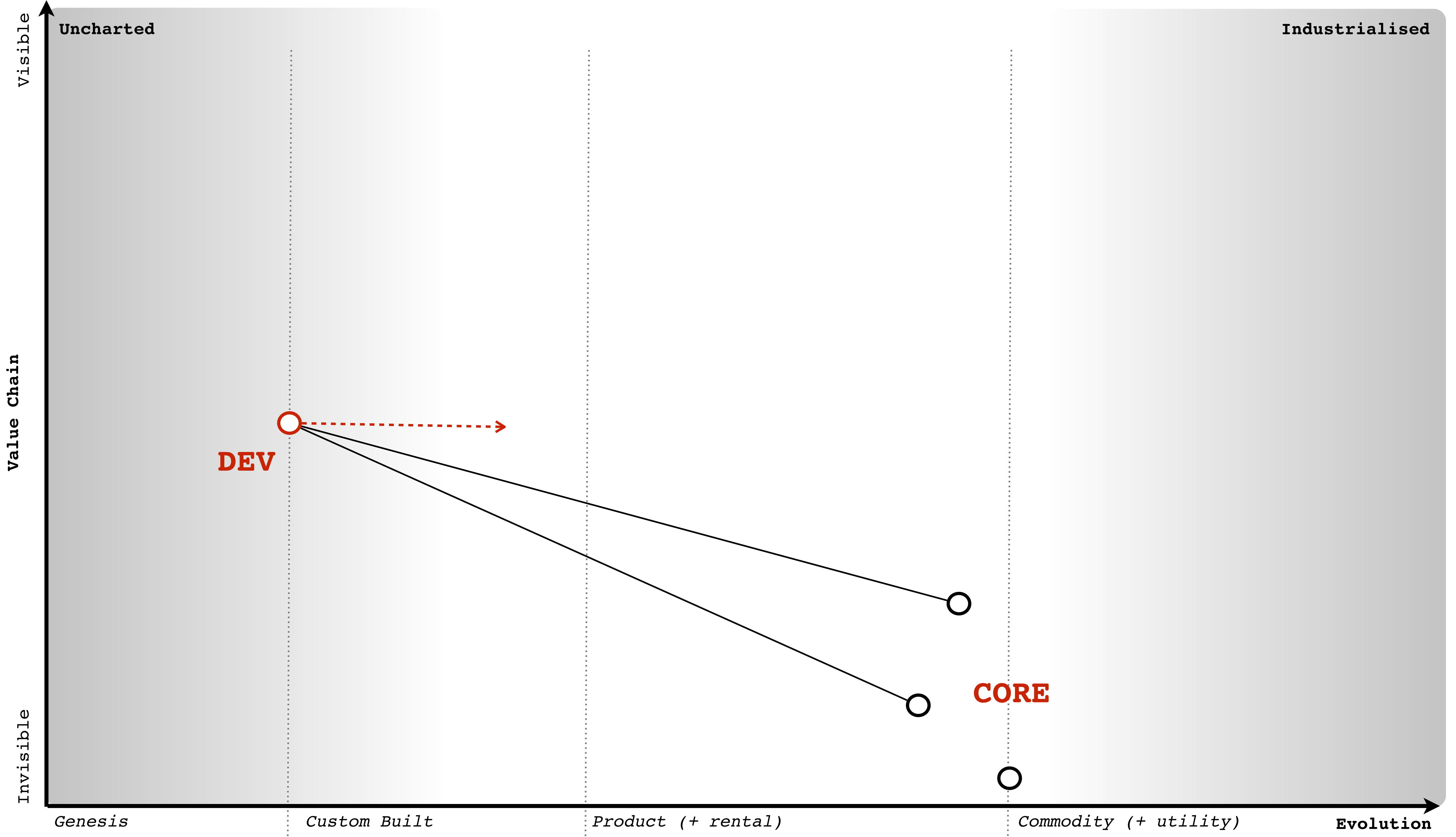

Uncharted

Industrialised

Visible

Value Chain

Invisible

Genesis

Custom Built

Product (+ rental)

Commodity (+ utility)

Evolution

DEV

CORE

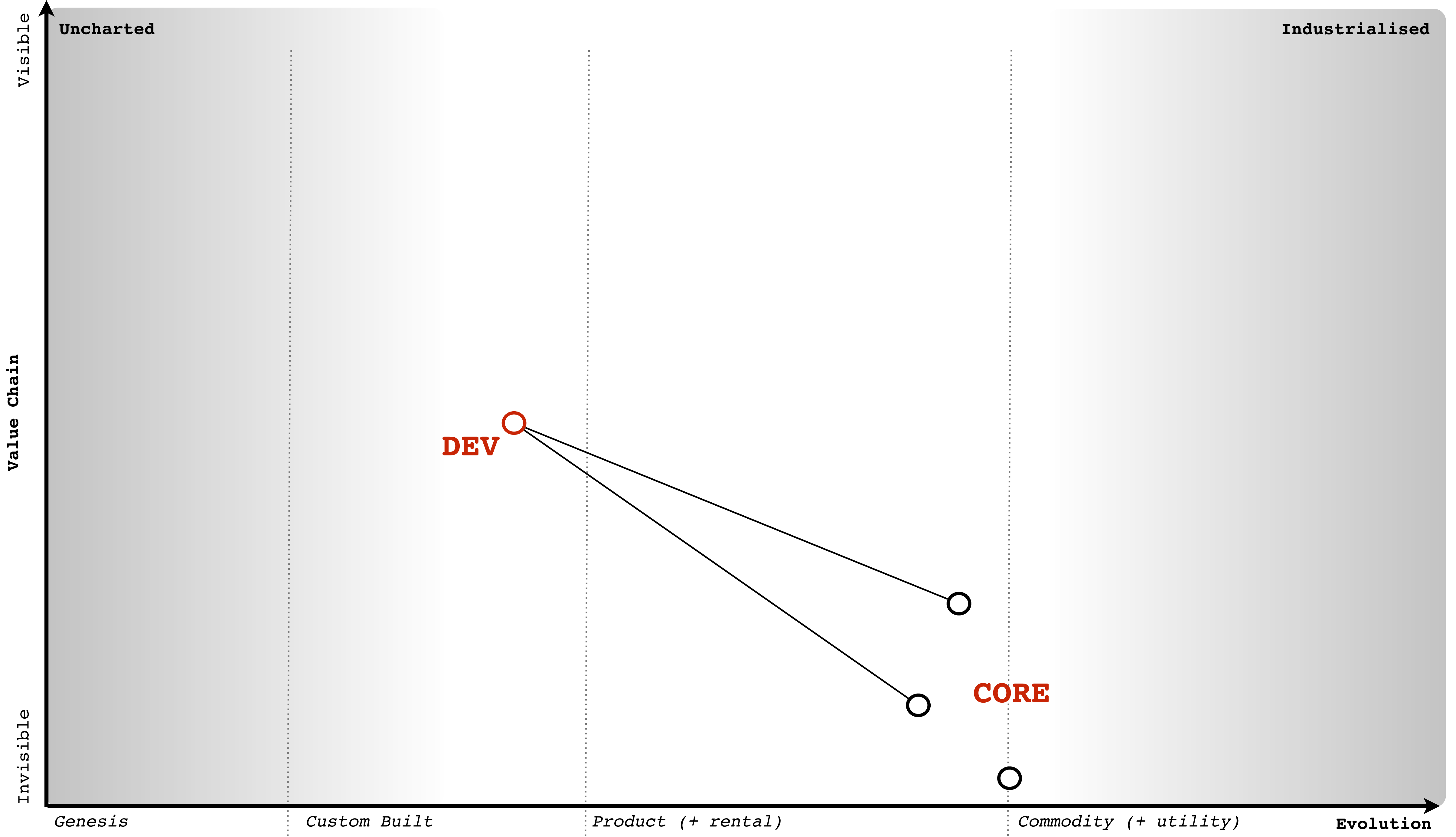

Visible

Uncharted

Industrialised

Value Chain

Invisible

Genesis

Custom Built

Product (+ rental)

Commodity (+ utility)

Evolution

DEV

CORE

Three ginger cats are dressed as the Three Kings. They are wearing red, hooded robes with gold crosses on their chests. The cat in the center is wearing a red crown. The cat on the right is holding a scroll. A white speech bubble with a black outline is positioned on the left side of the image, containing the text "You look after this!".

You look
after this!



You look
after this!

Where's the
documentation?



Burn
them!

Heretic

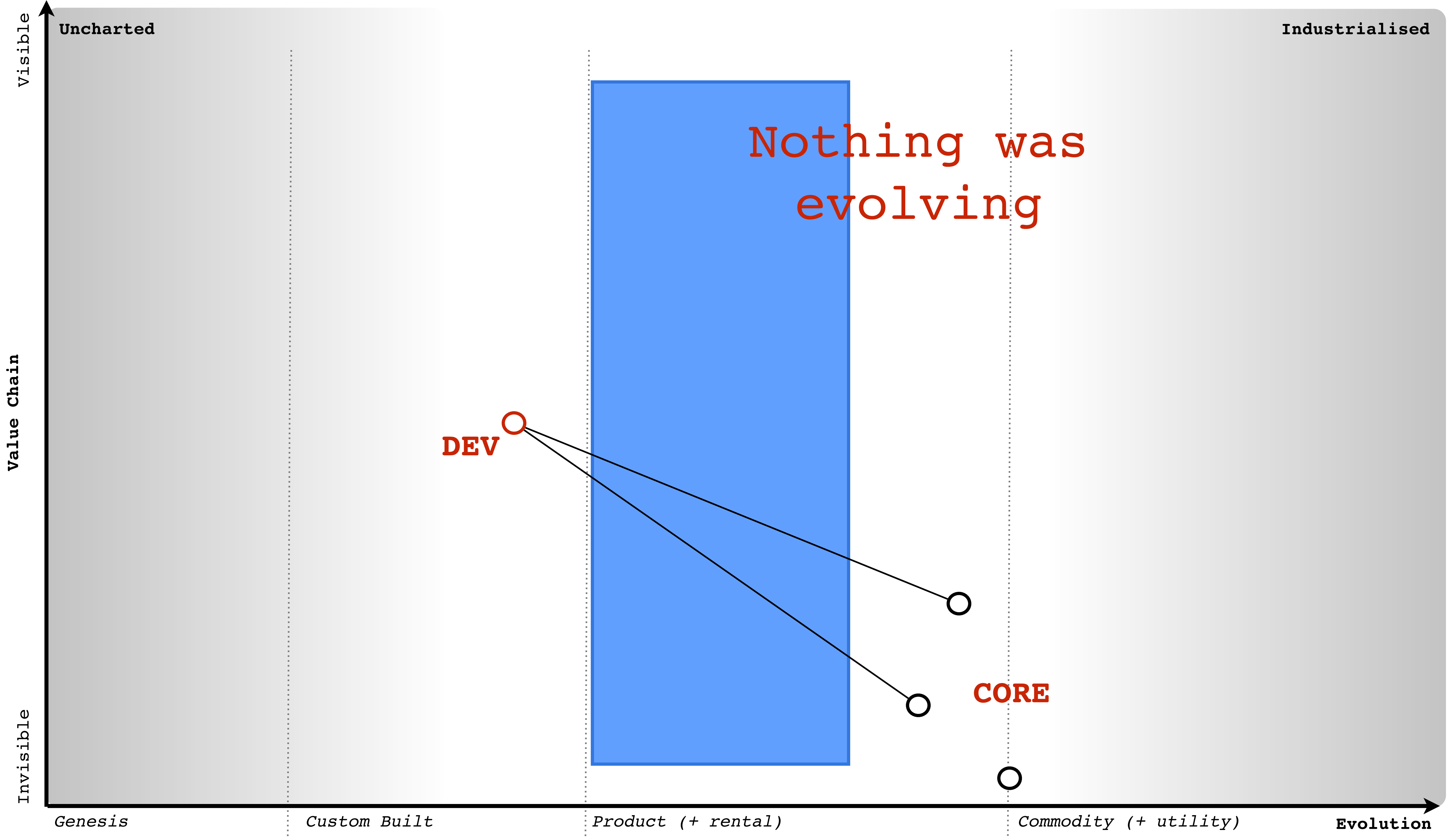

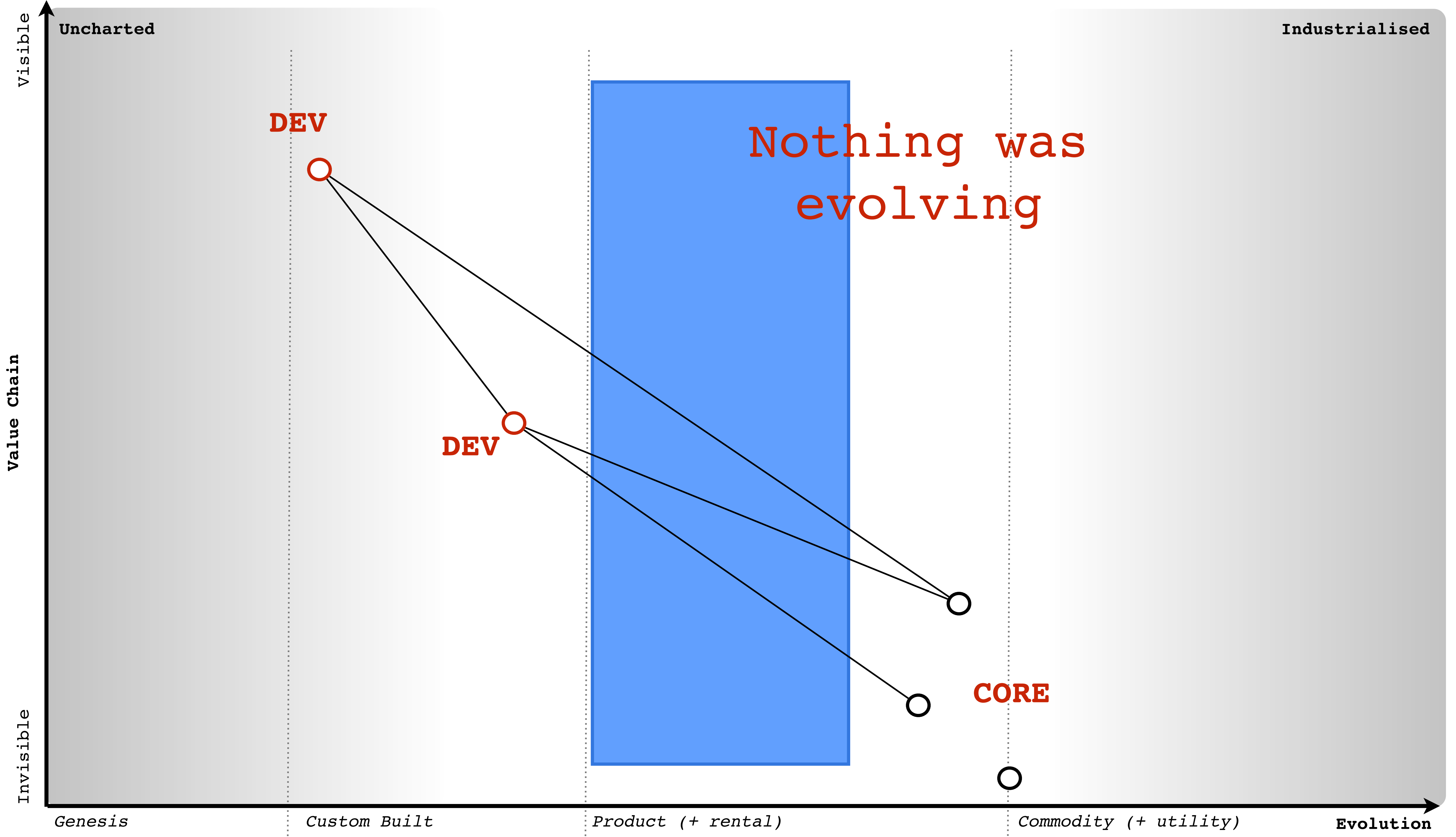

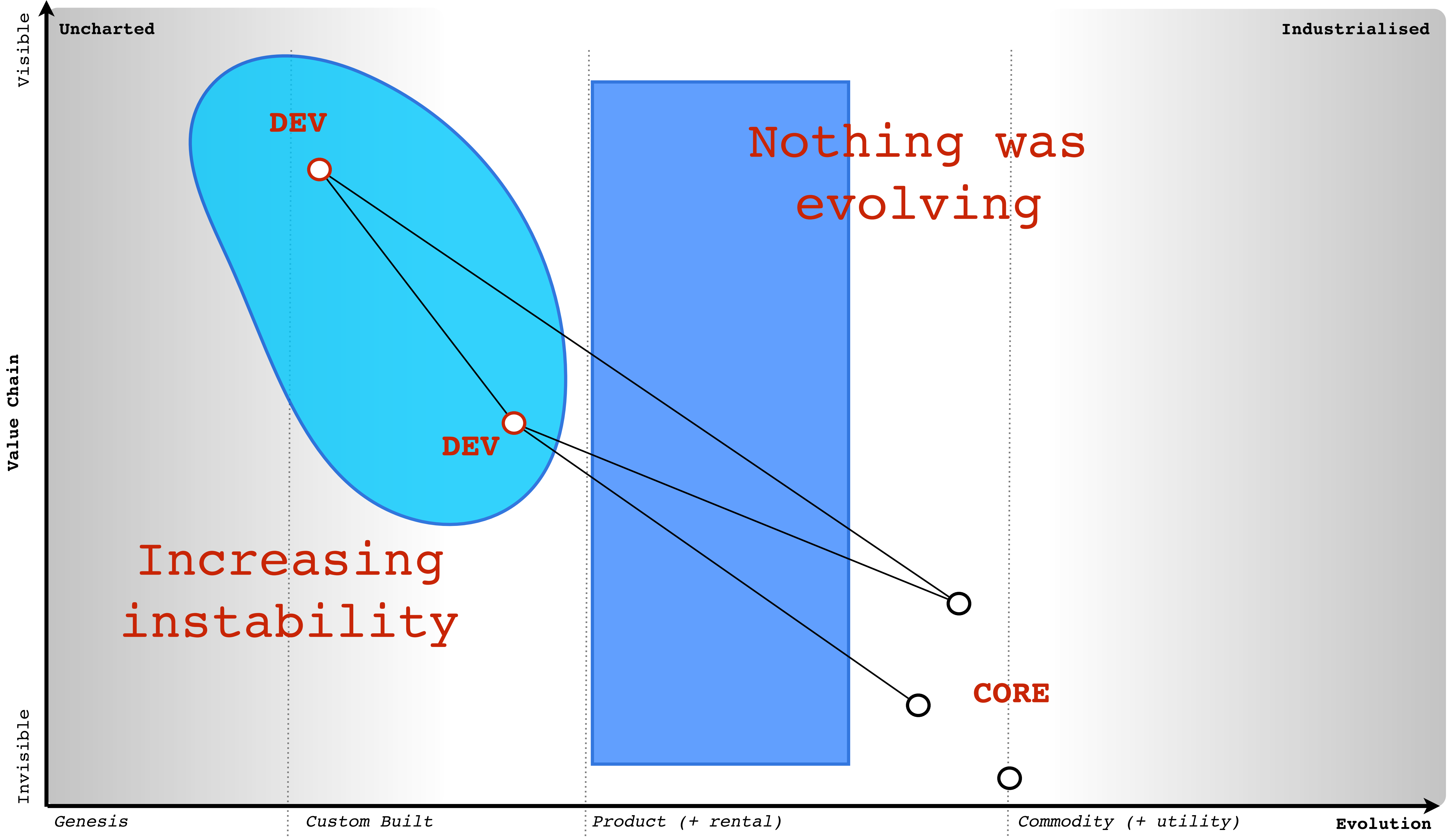

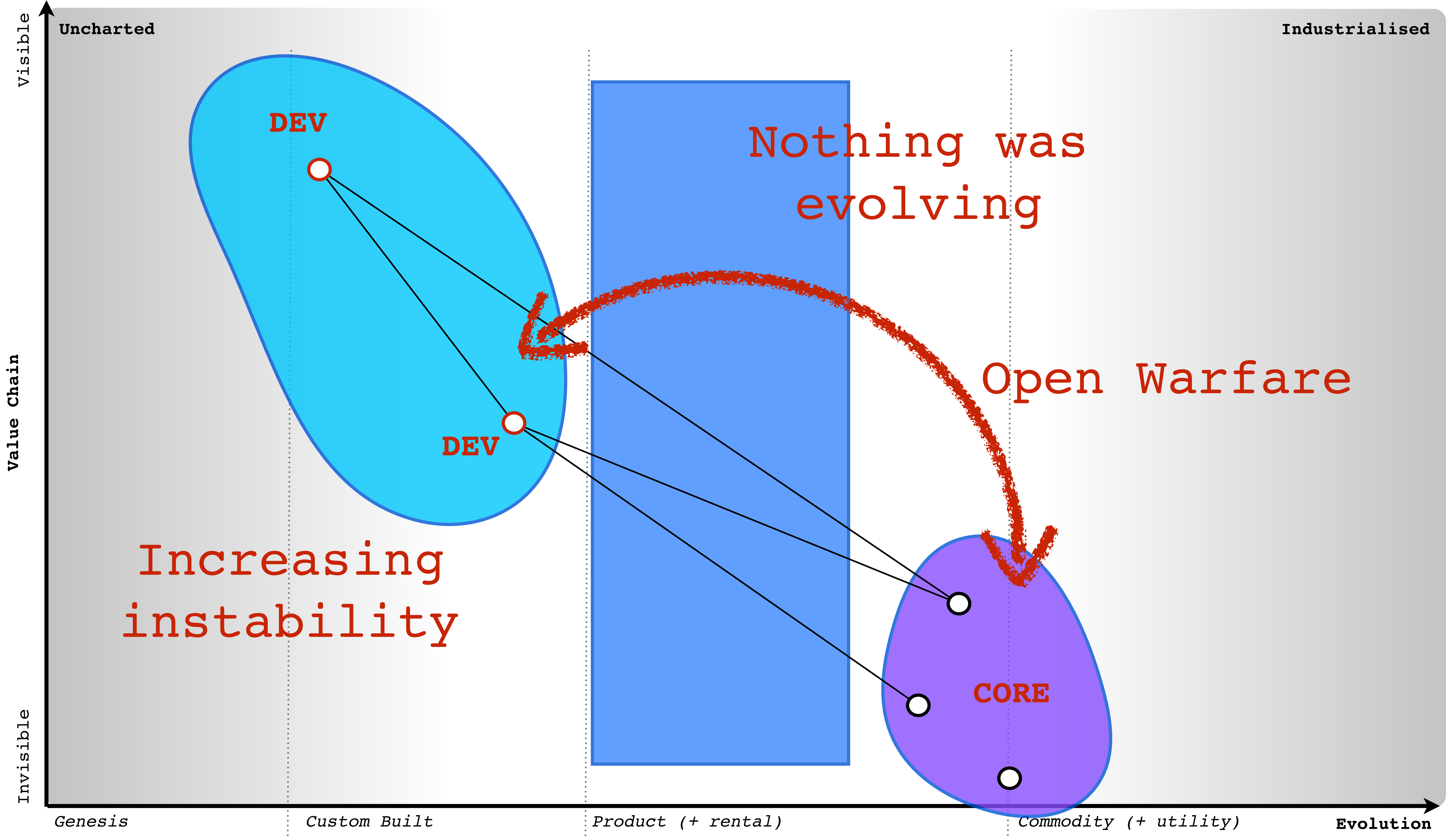

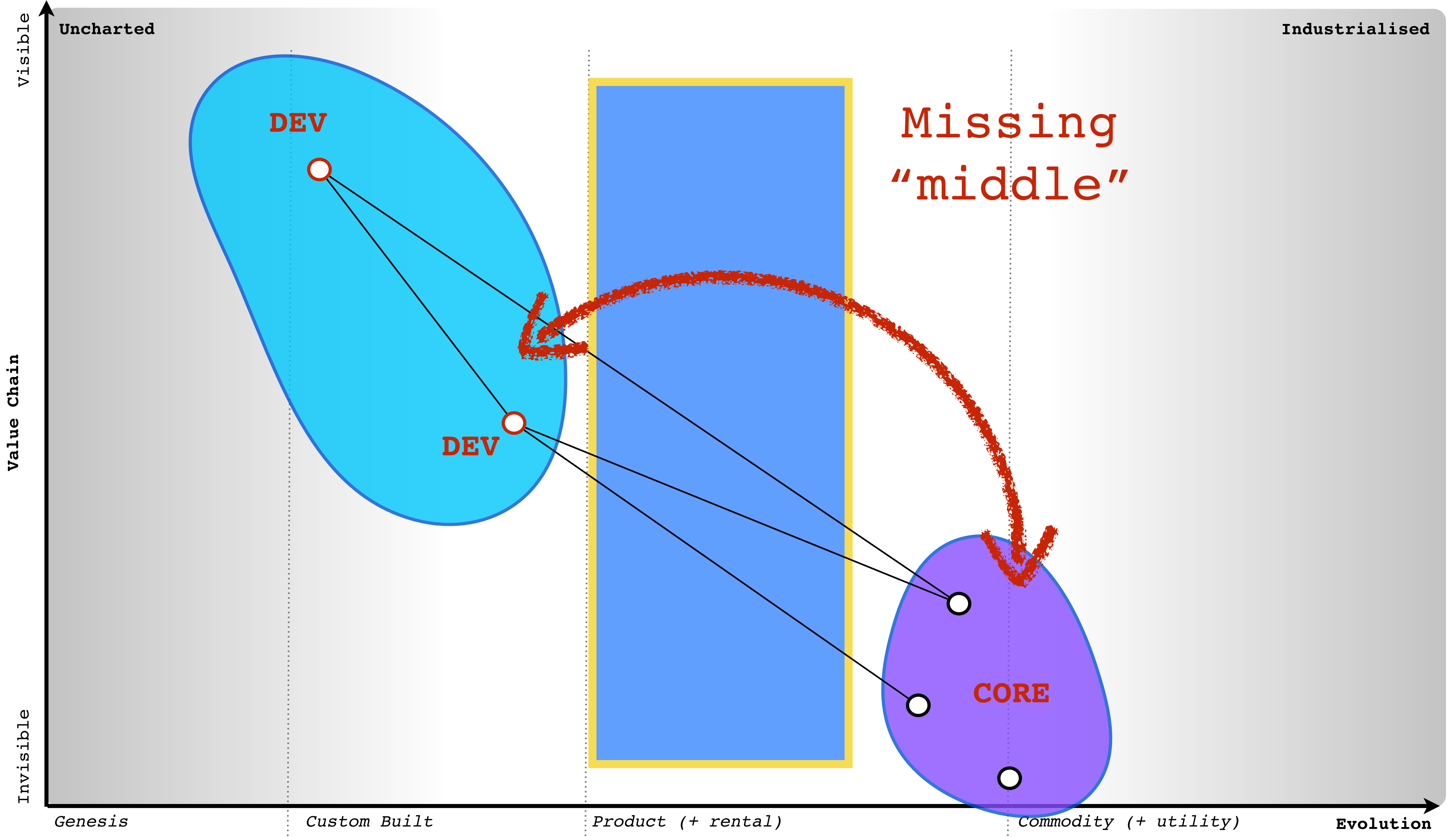

CEO

Chief
Pioneer

Chief
Settler

Chief
TP

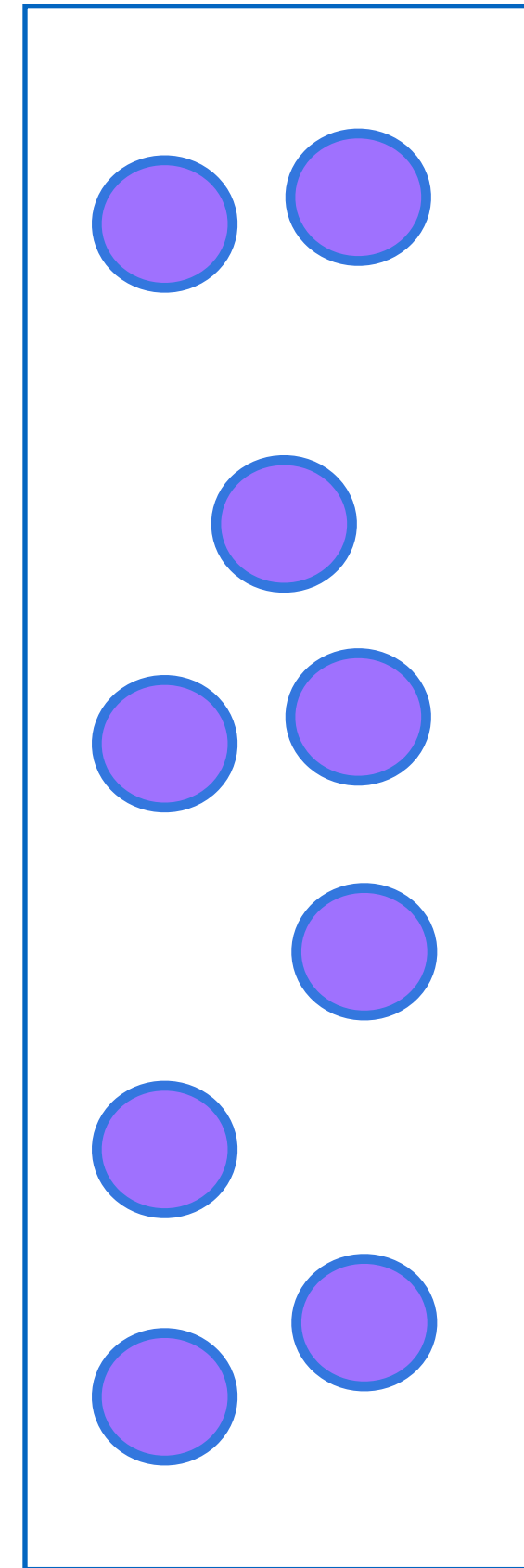
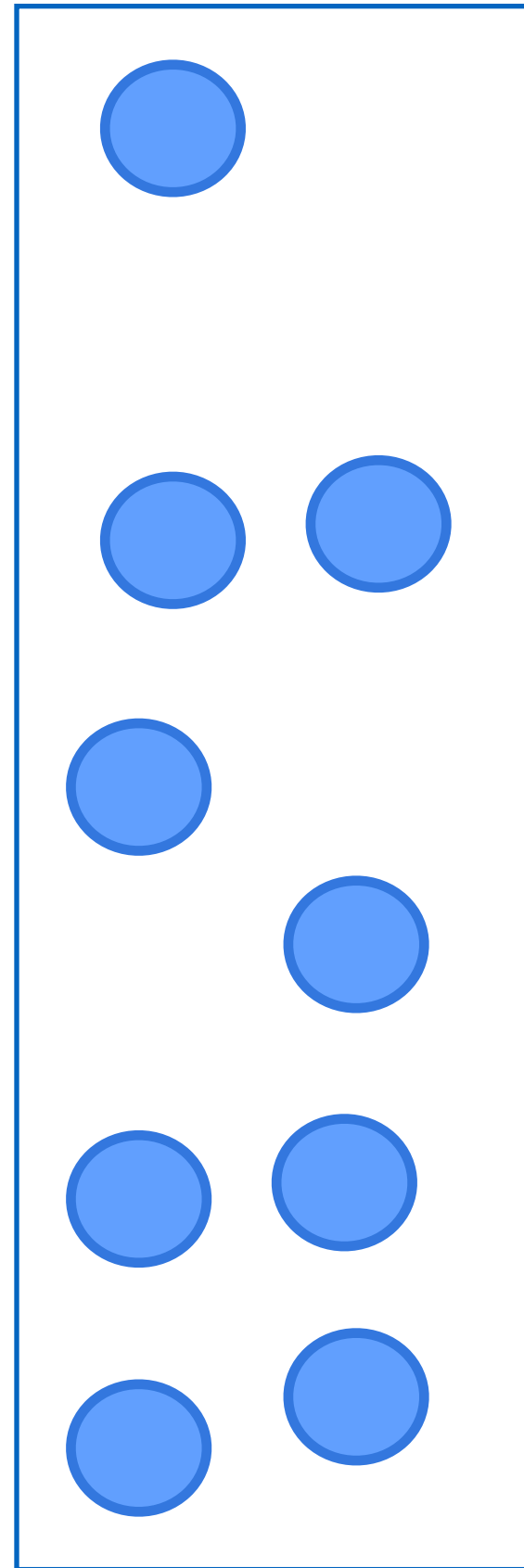
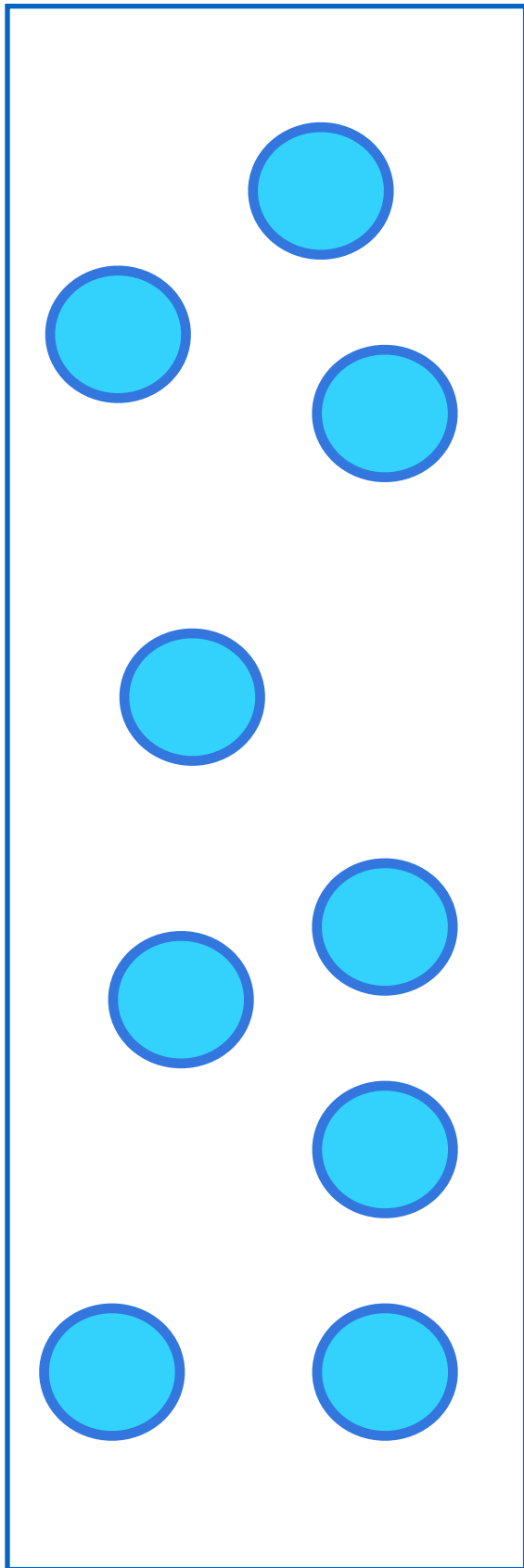

CEO

Chief
Pioneer

Chief
Settler

Chief
TP

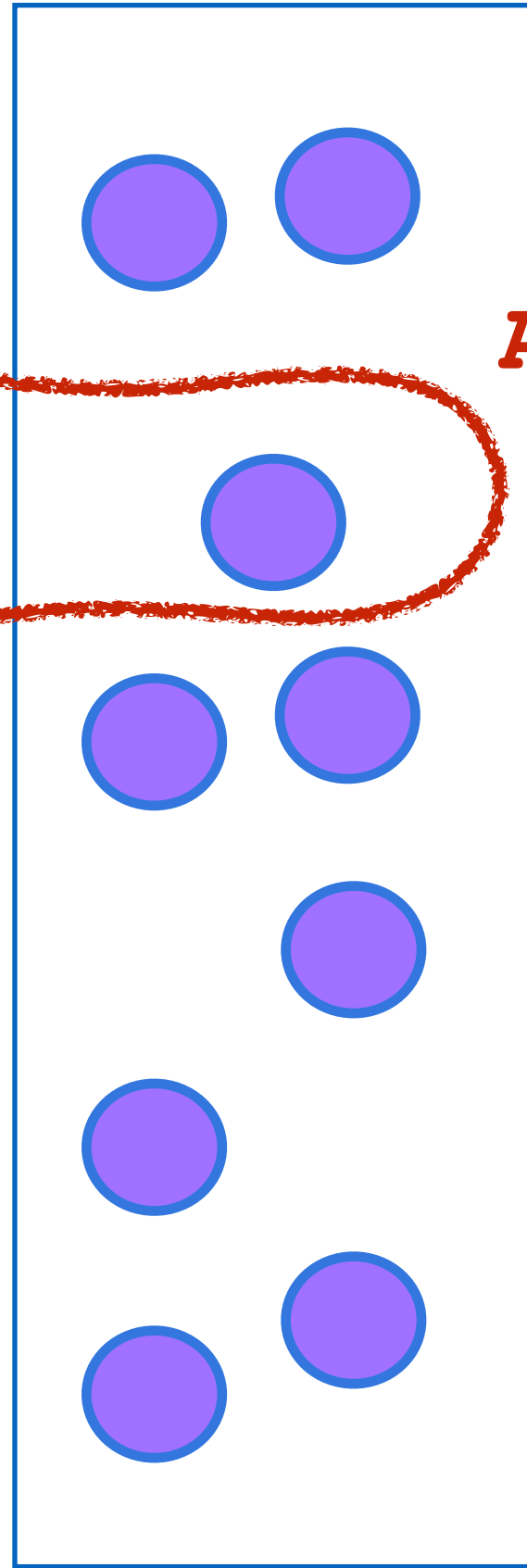
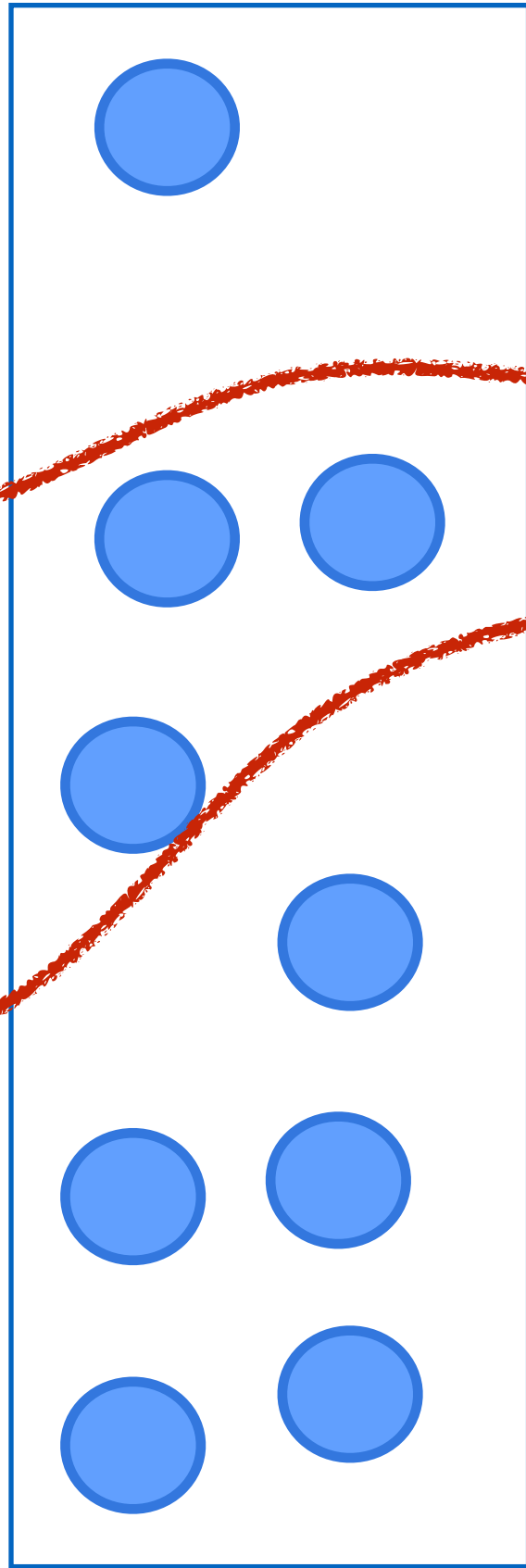
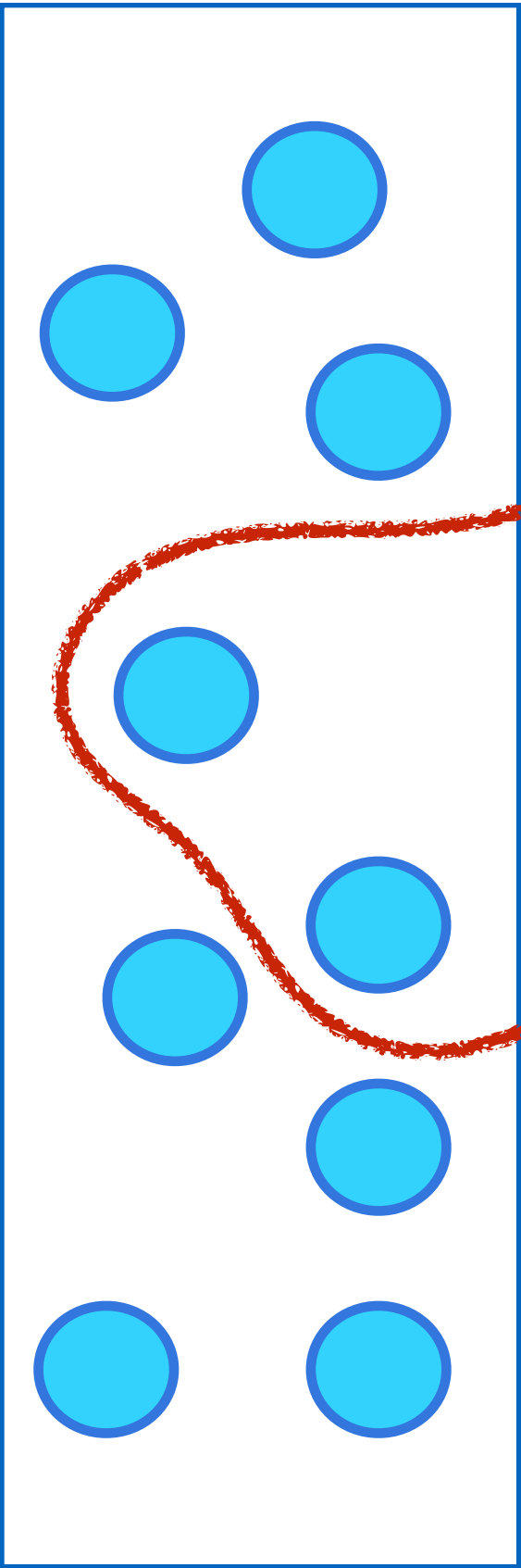

APTITUDES

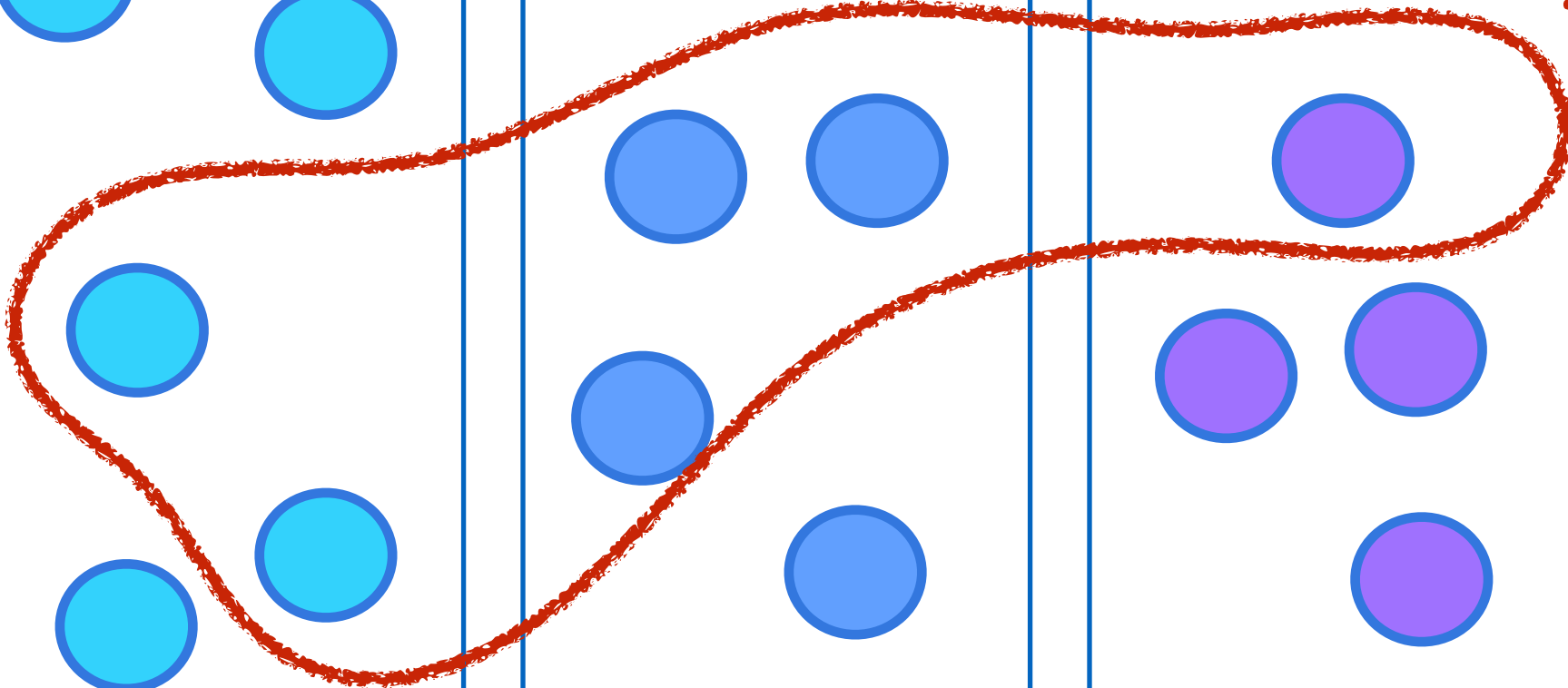

CEO

Chief
Pioneer

Chief
Settler

Chief
TP

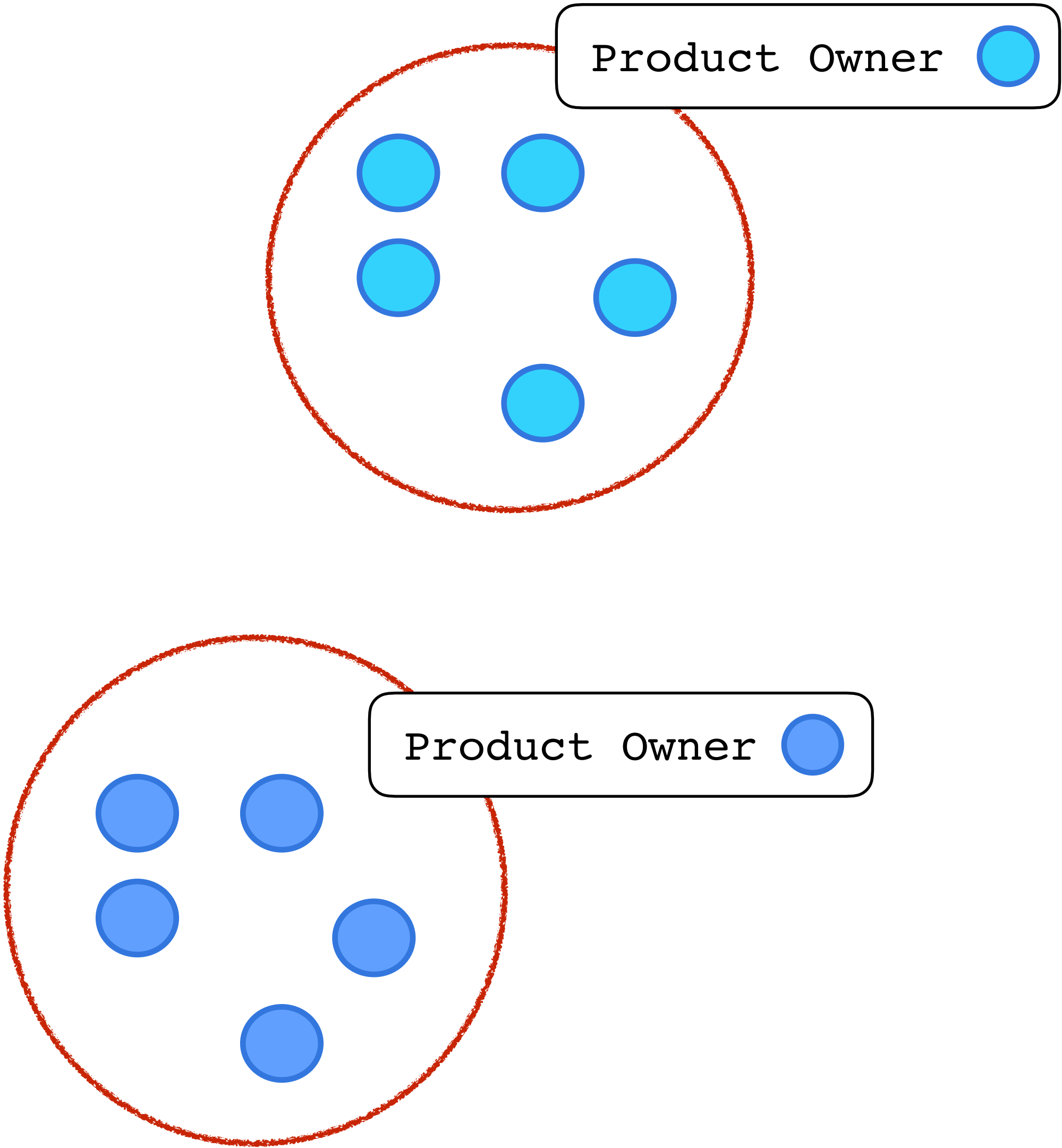
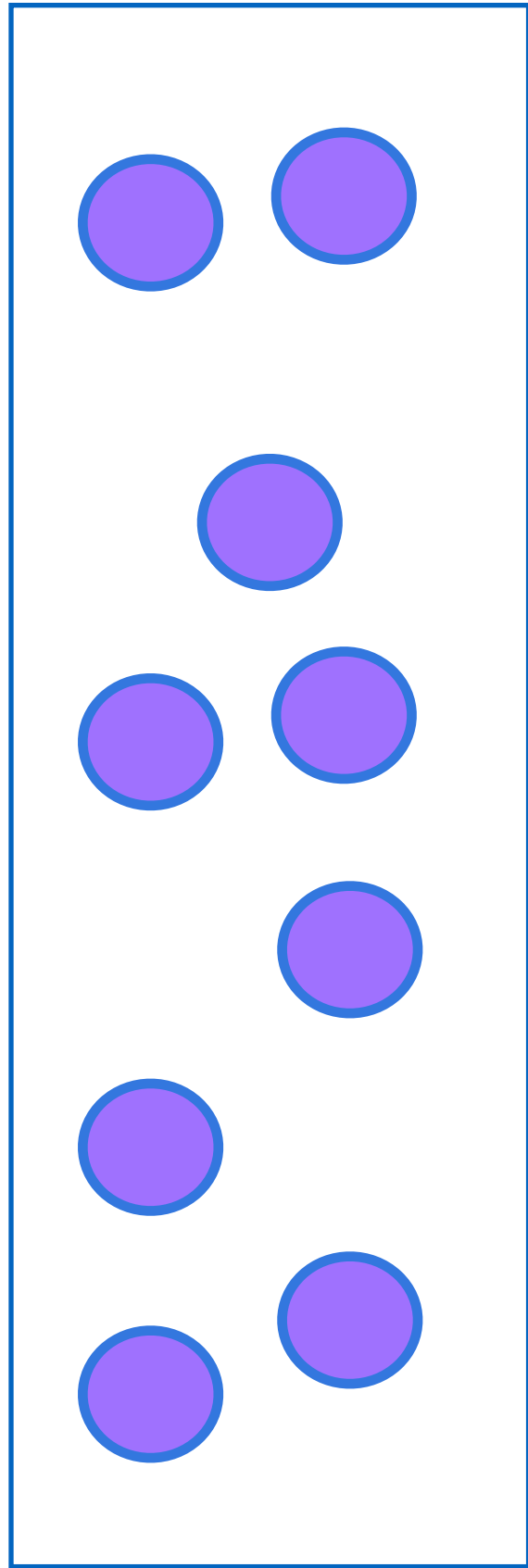
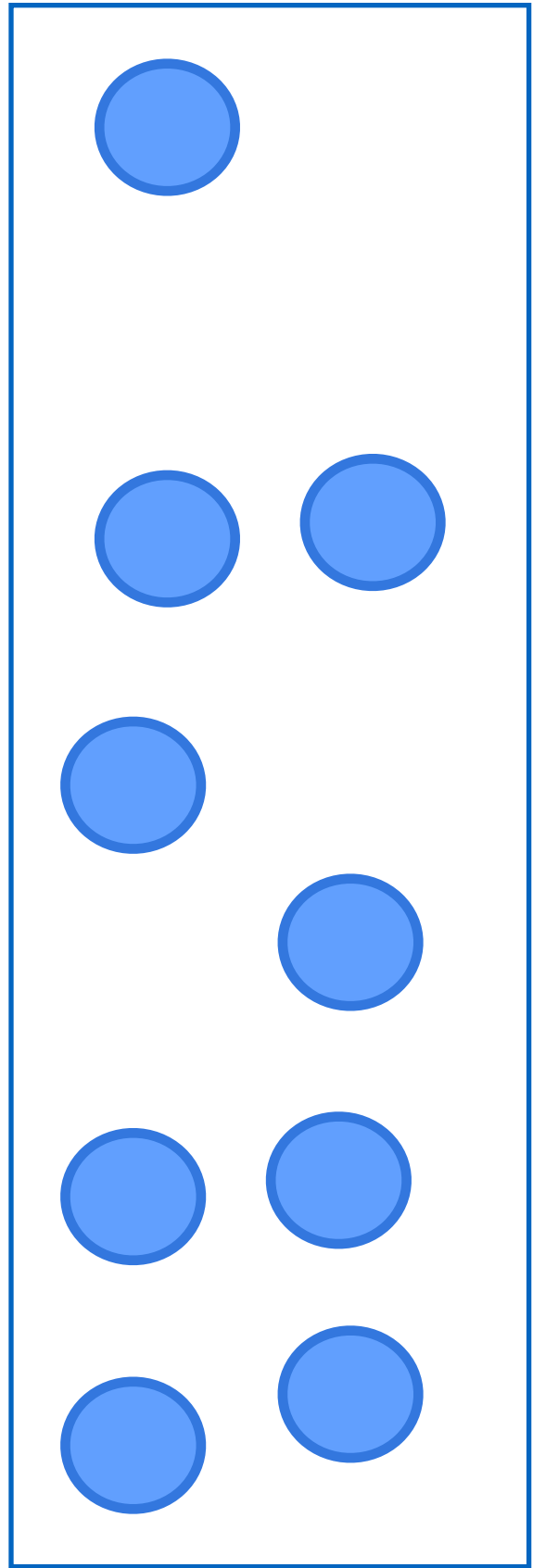
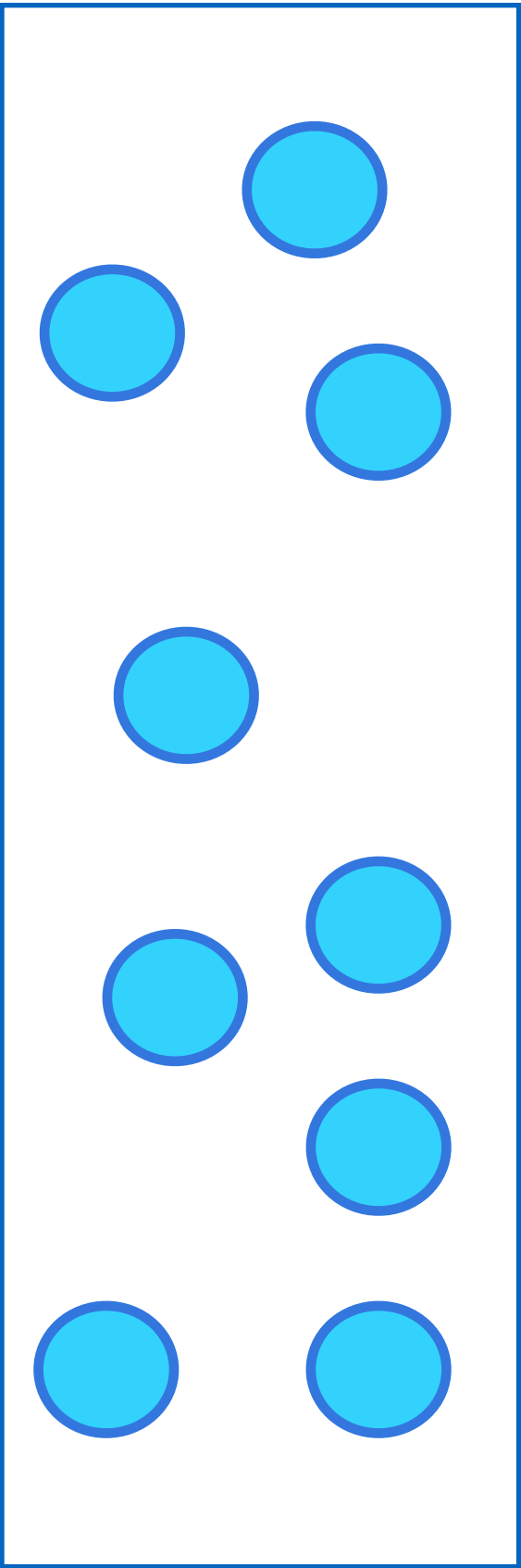

CEO

Chief
Pioneer

Chief
Settler

Chief
TP

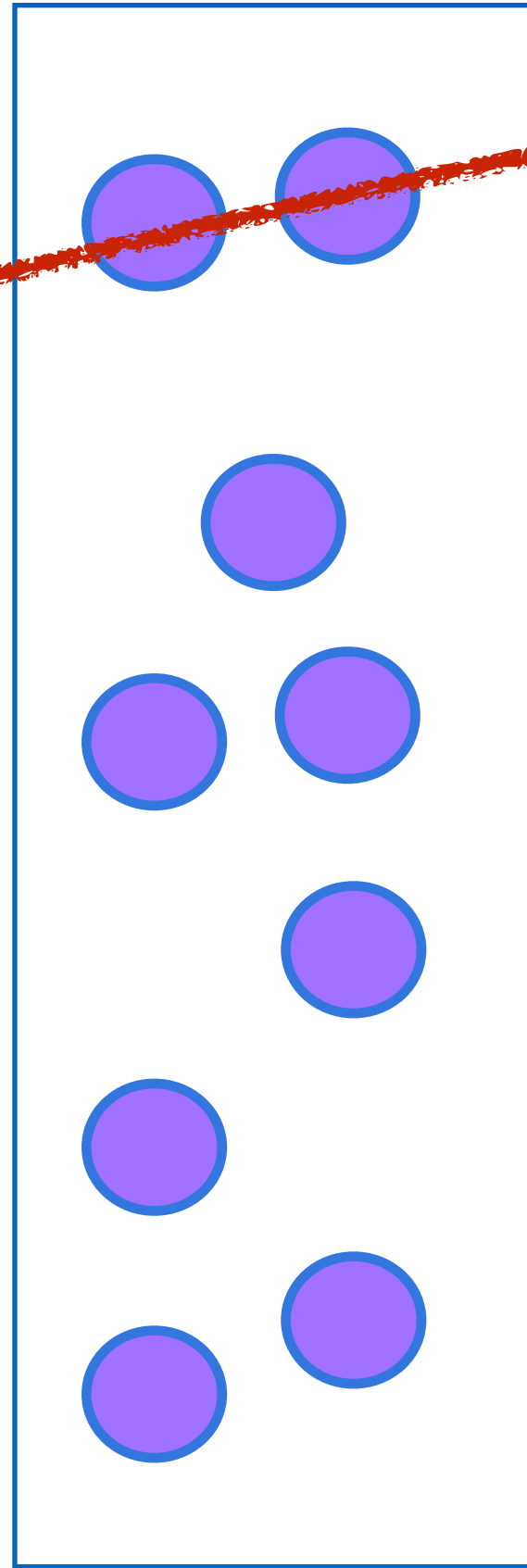
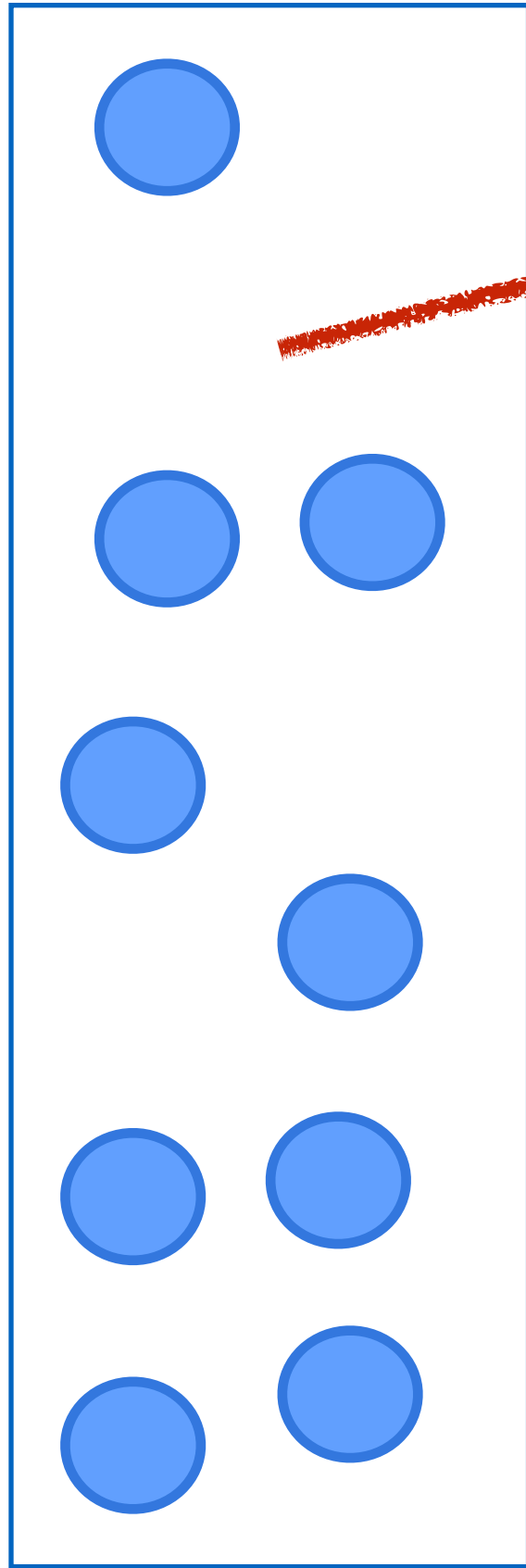
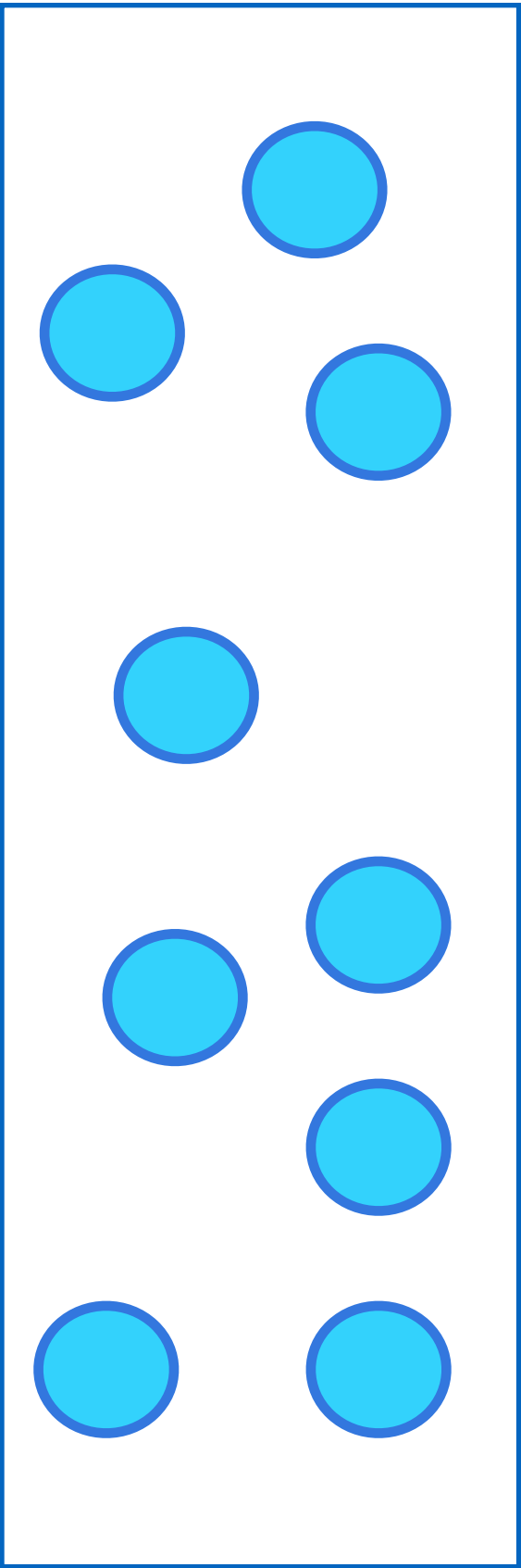

Product Owner 

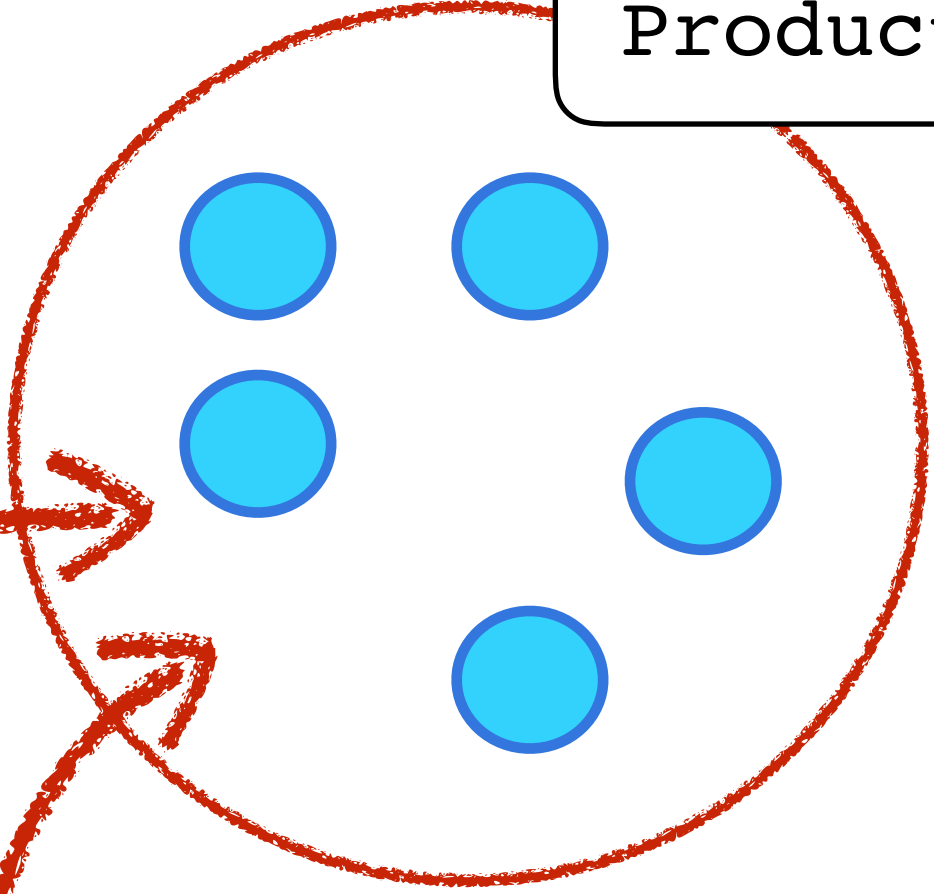

Product Owner 

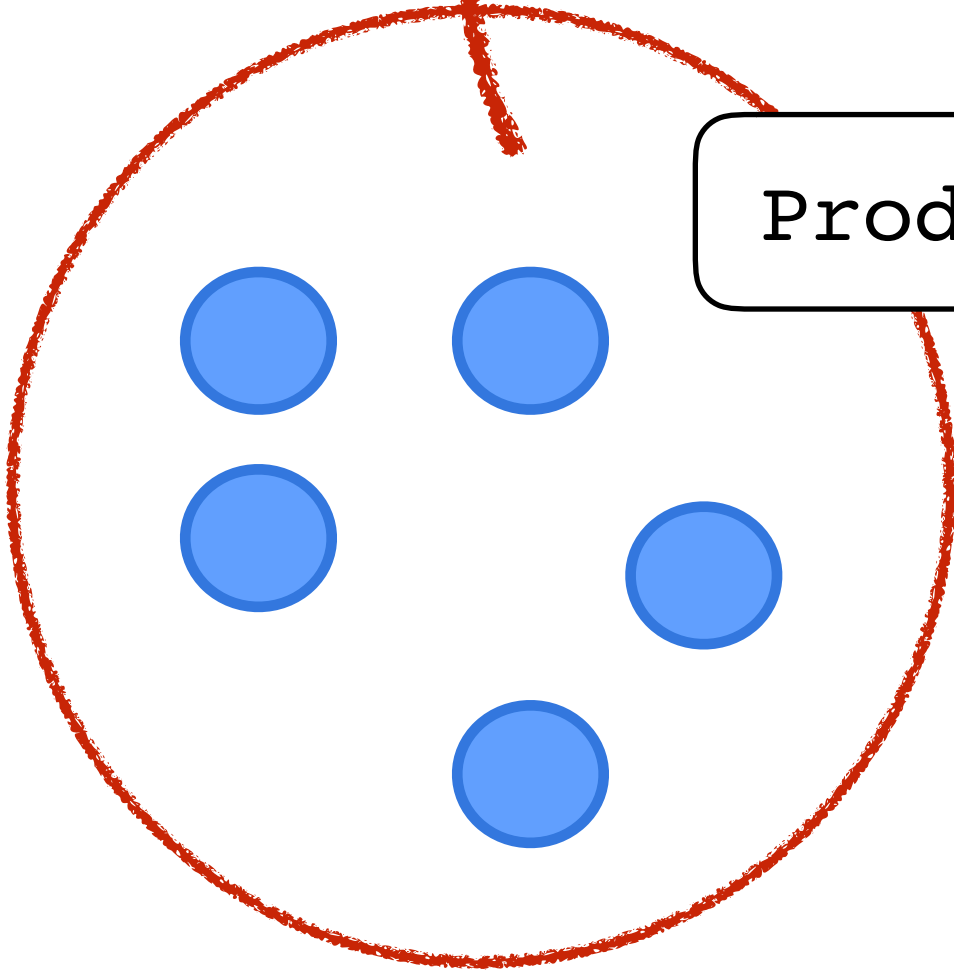

CEO

Chief Pioneer

Chief Settler

Chief TP

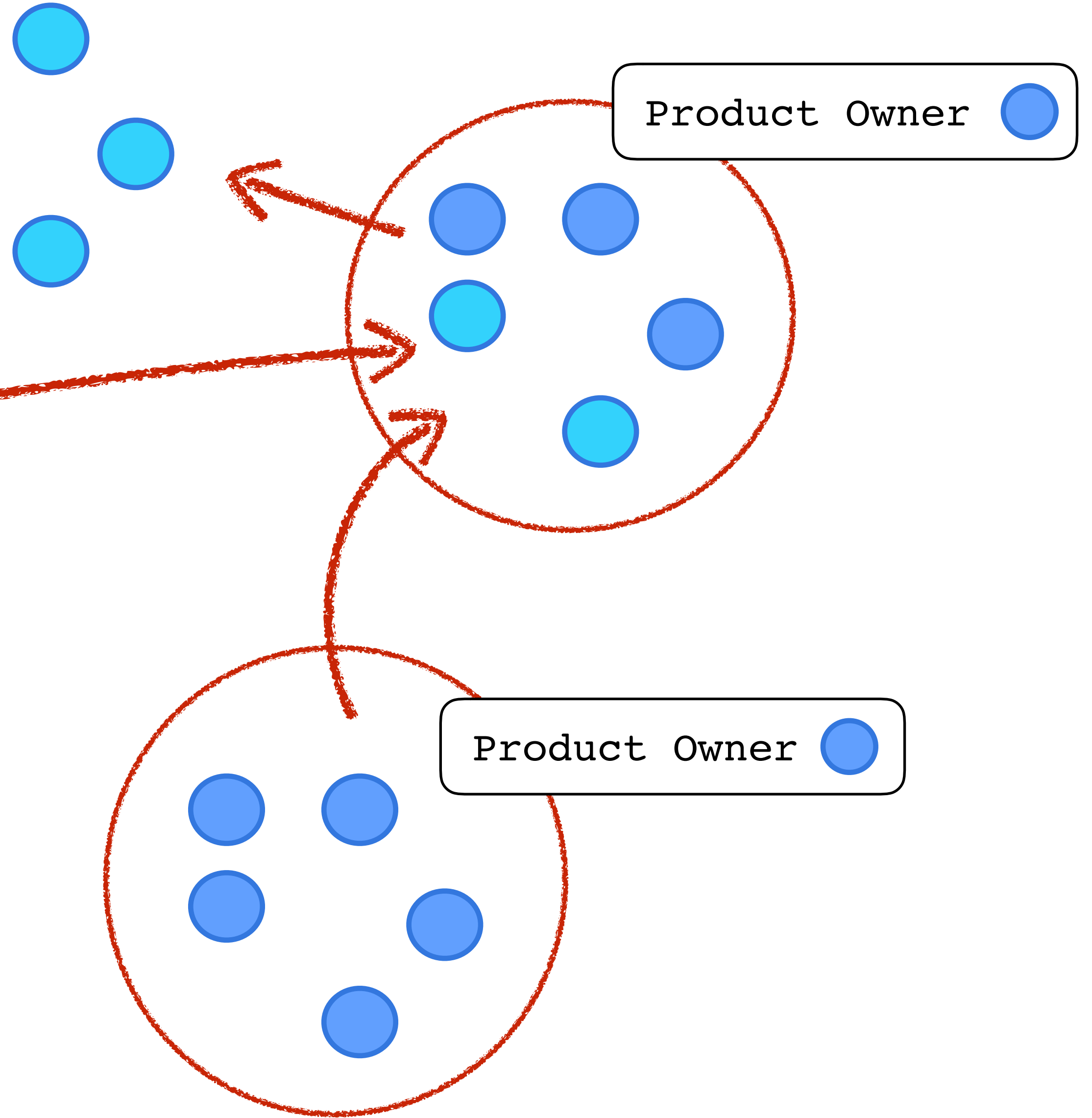
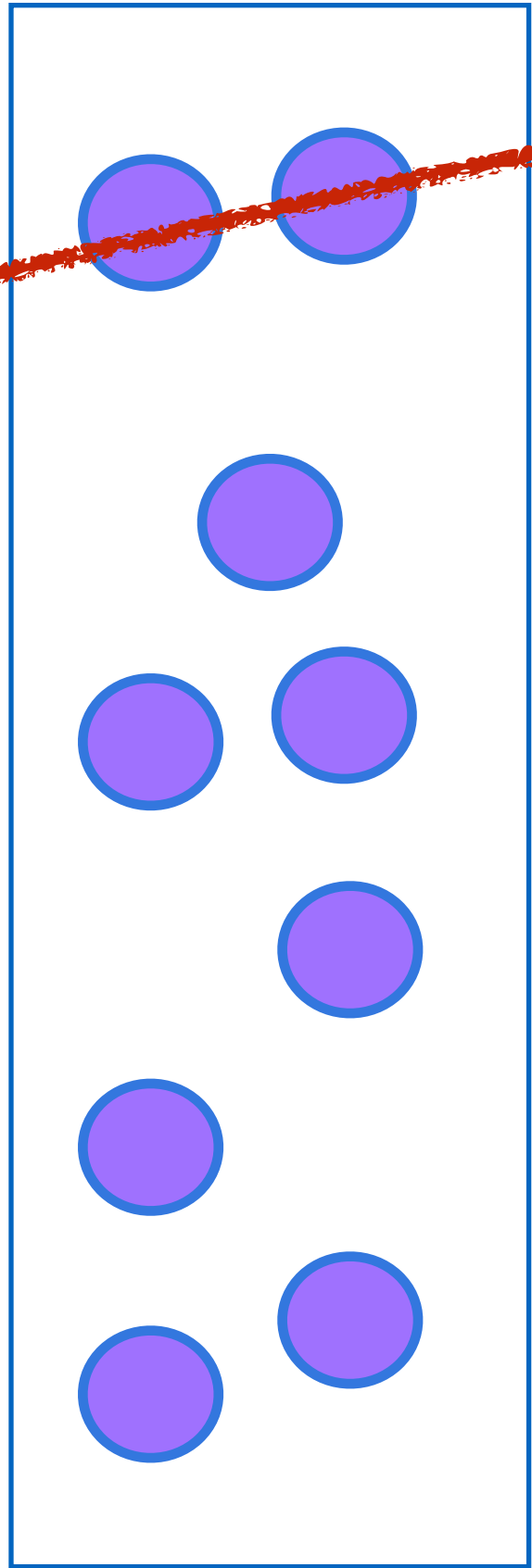
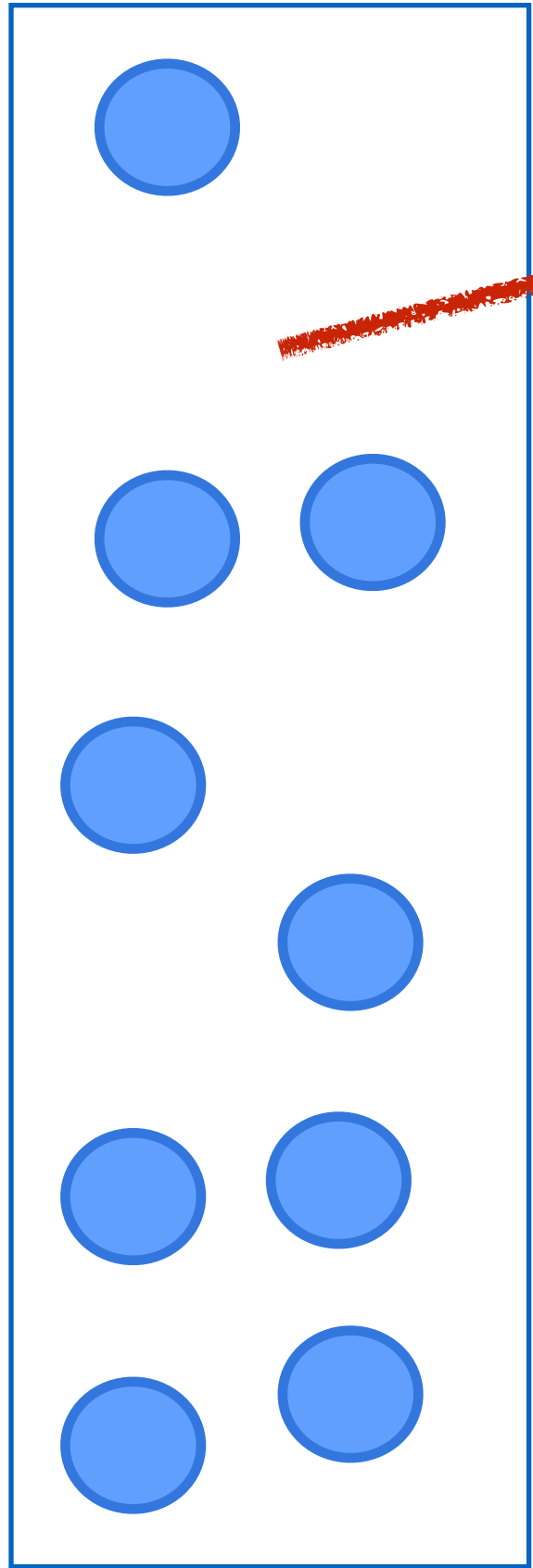
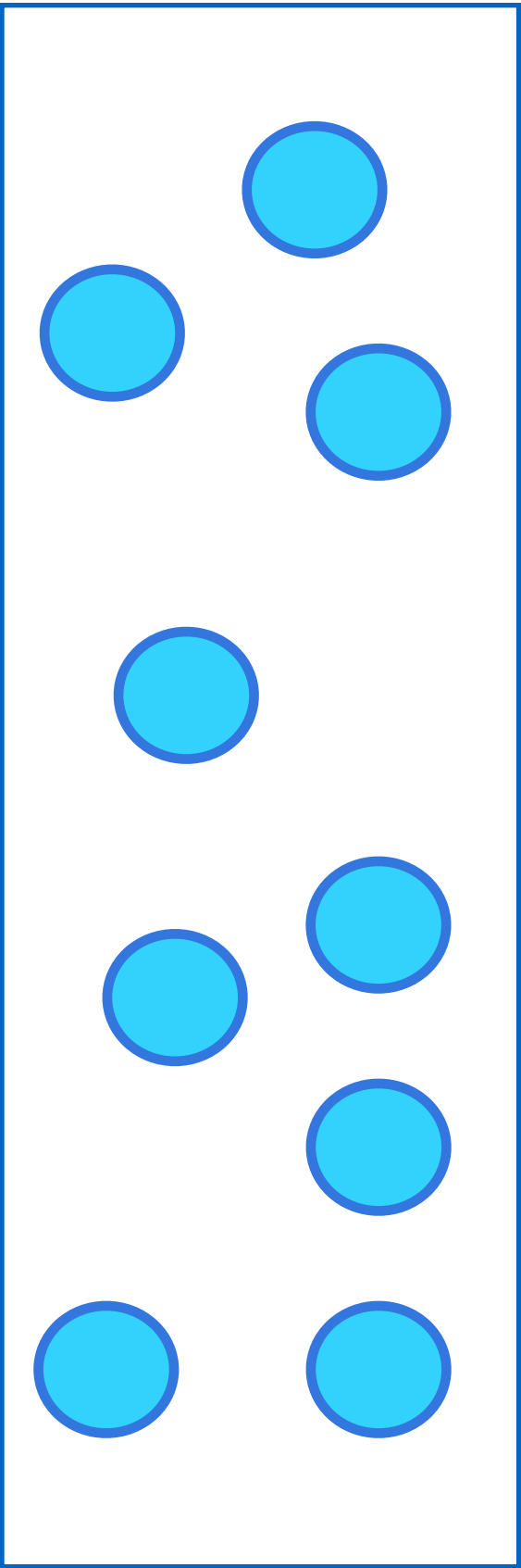

CEO

Chief Pioneer

Chief Settler

Chief TP

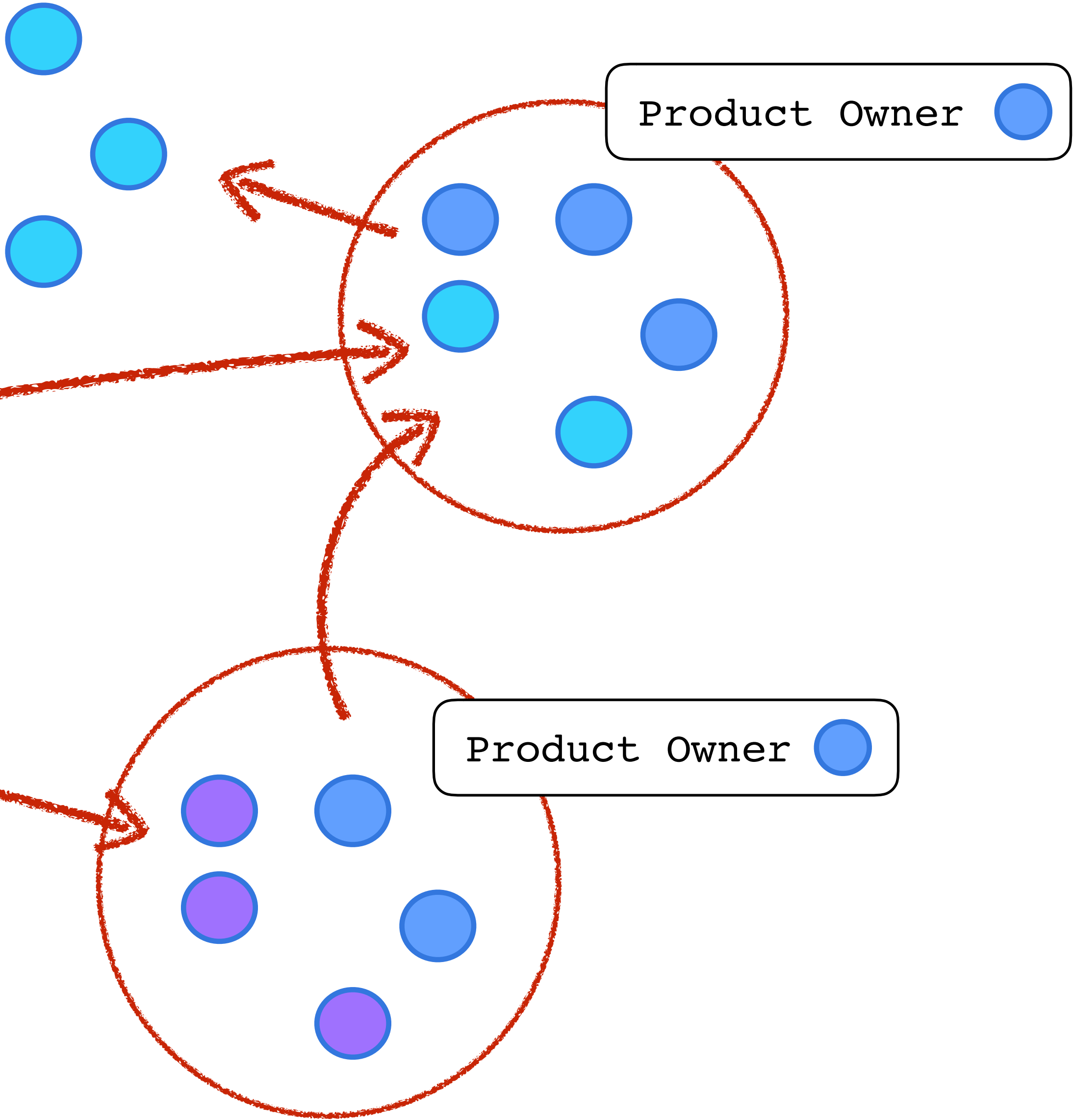
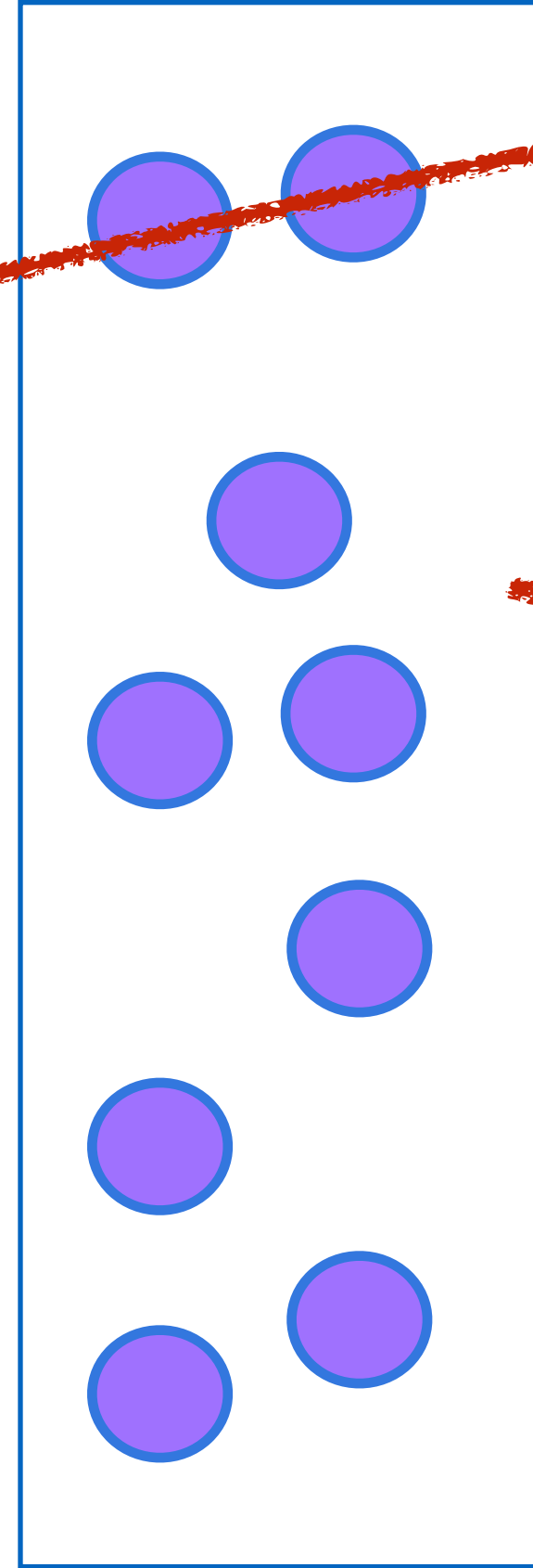
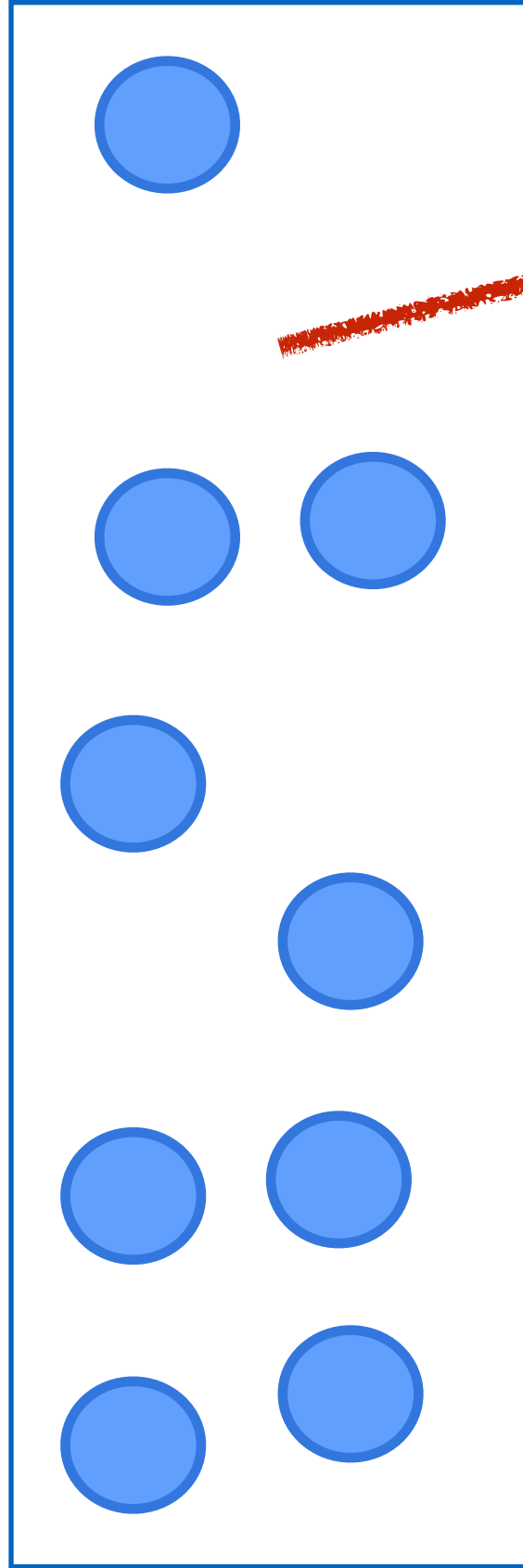
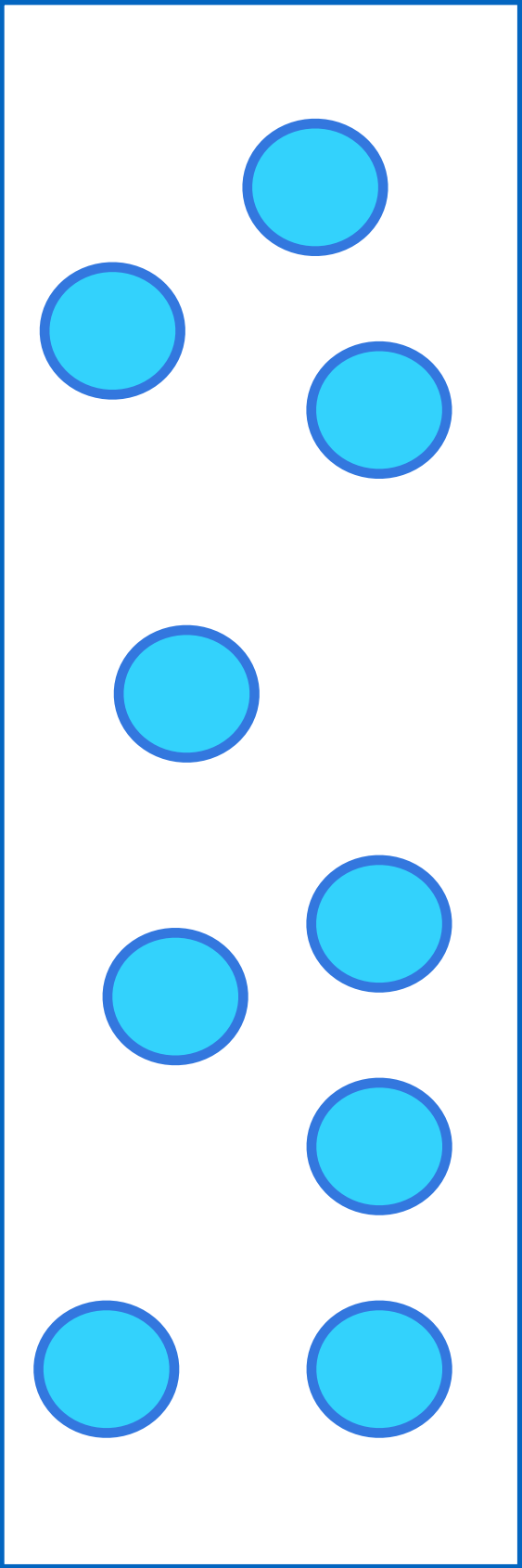

CEO

Chief
Pioneer

Chief
Settler

Chief
TP

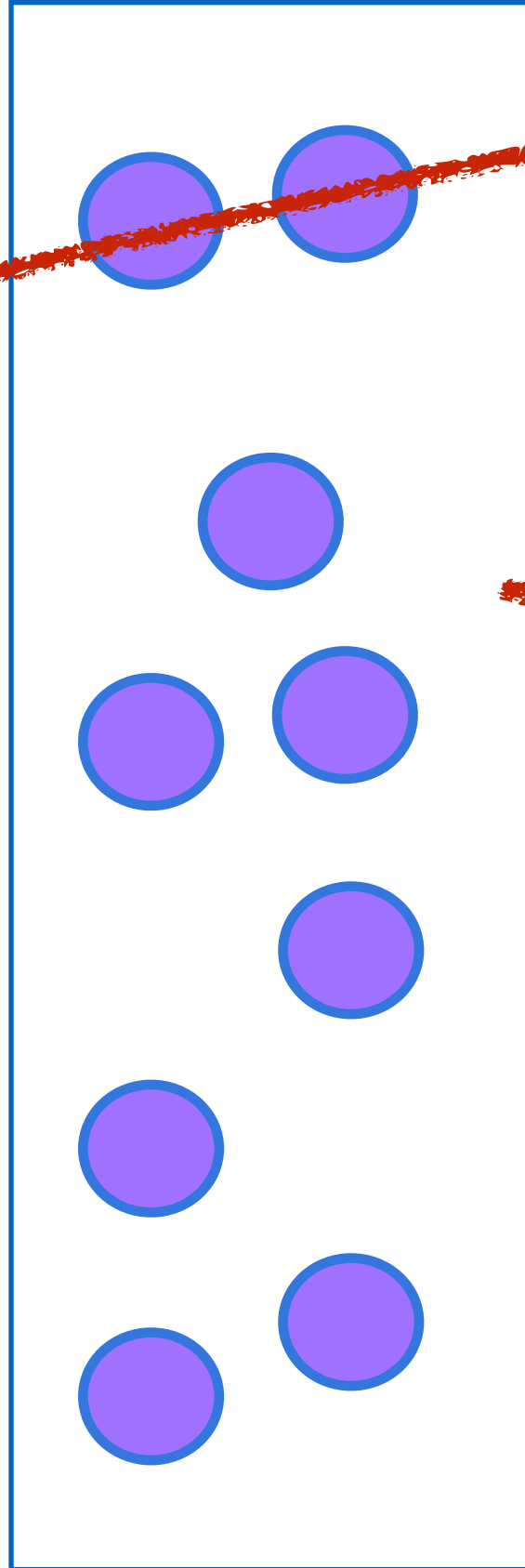
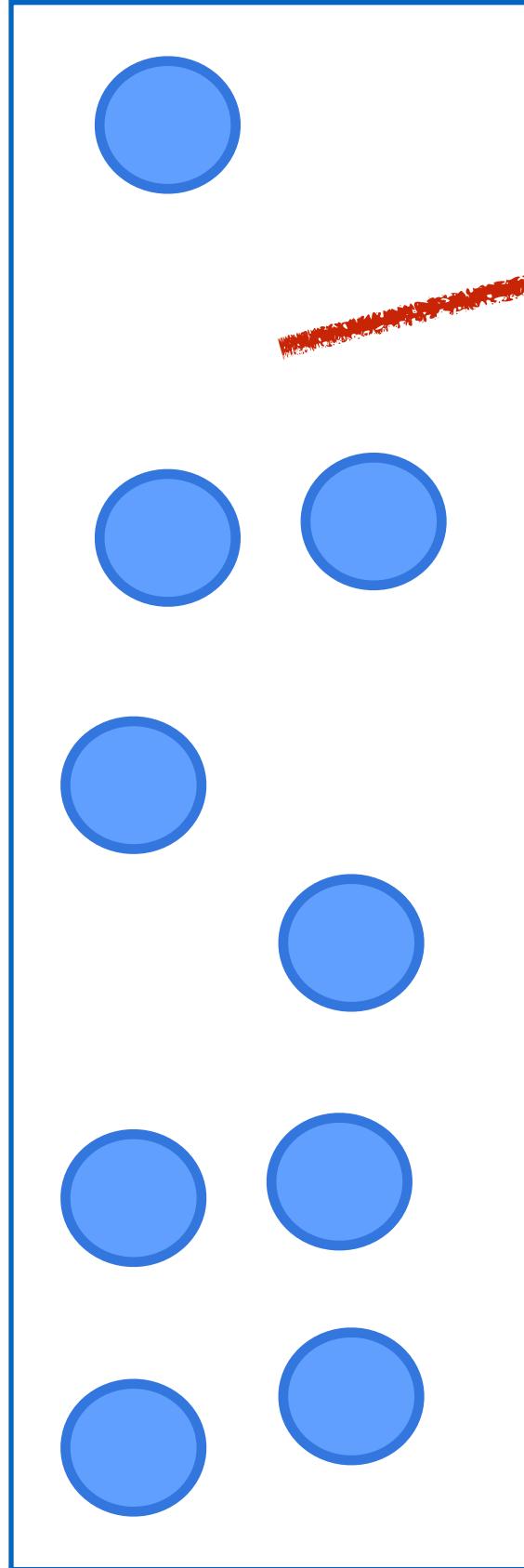
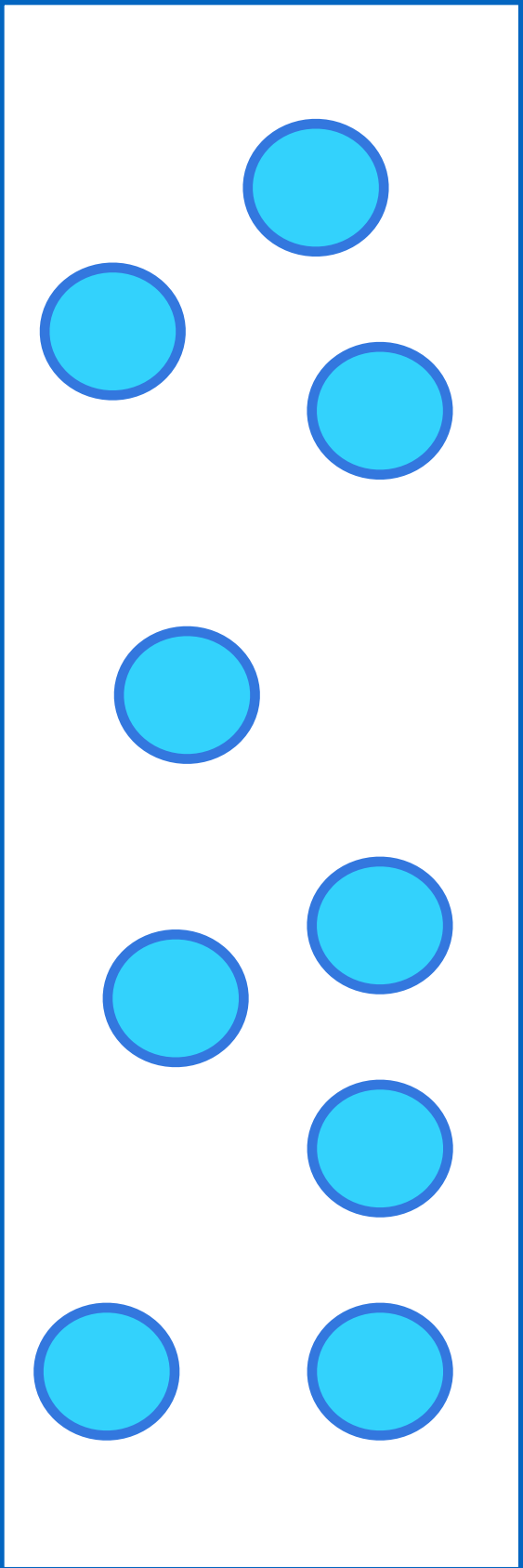

**SYSTEM OF
THEFT**

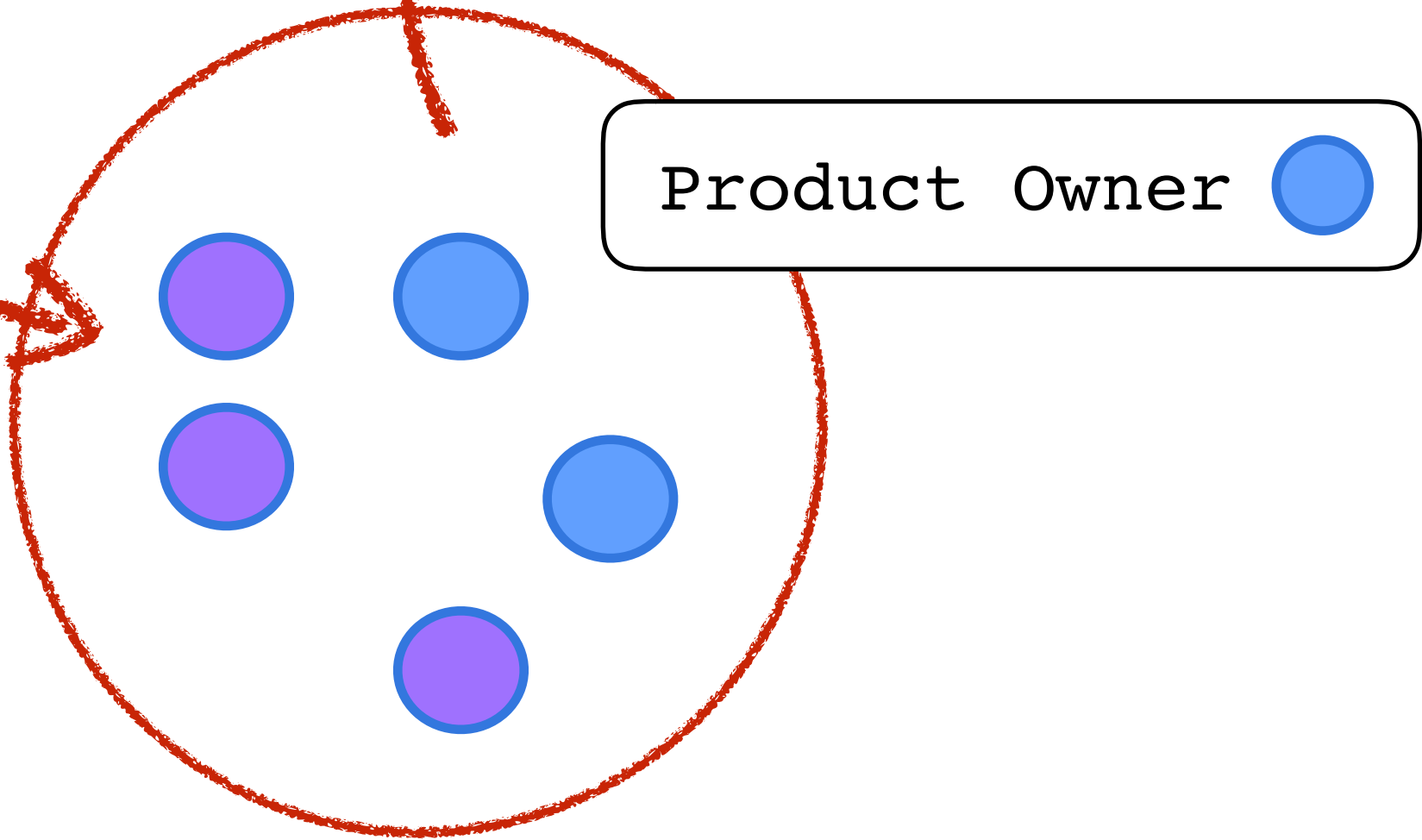
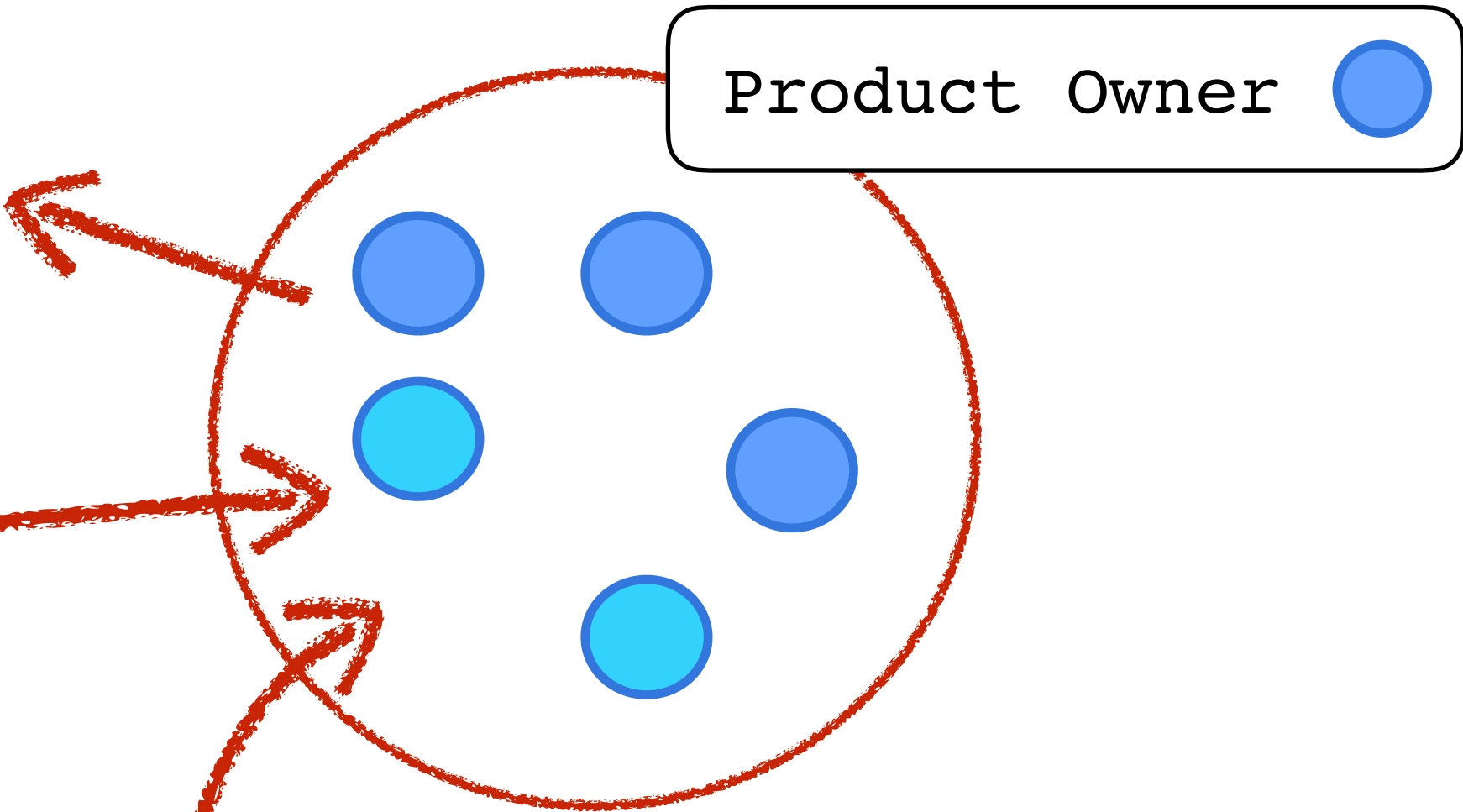
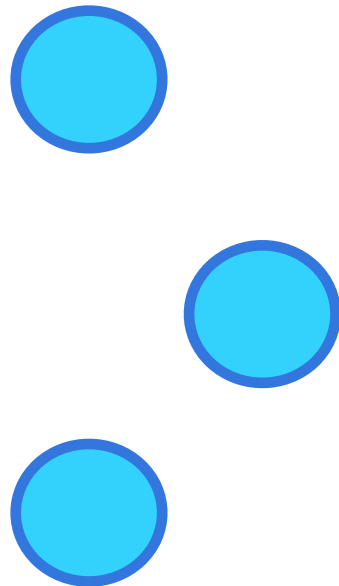

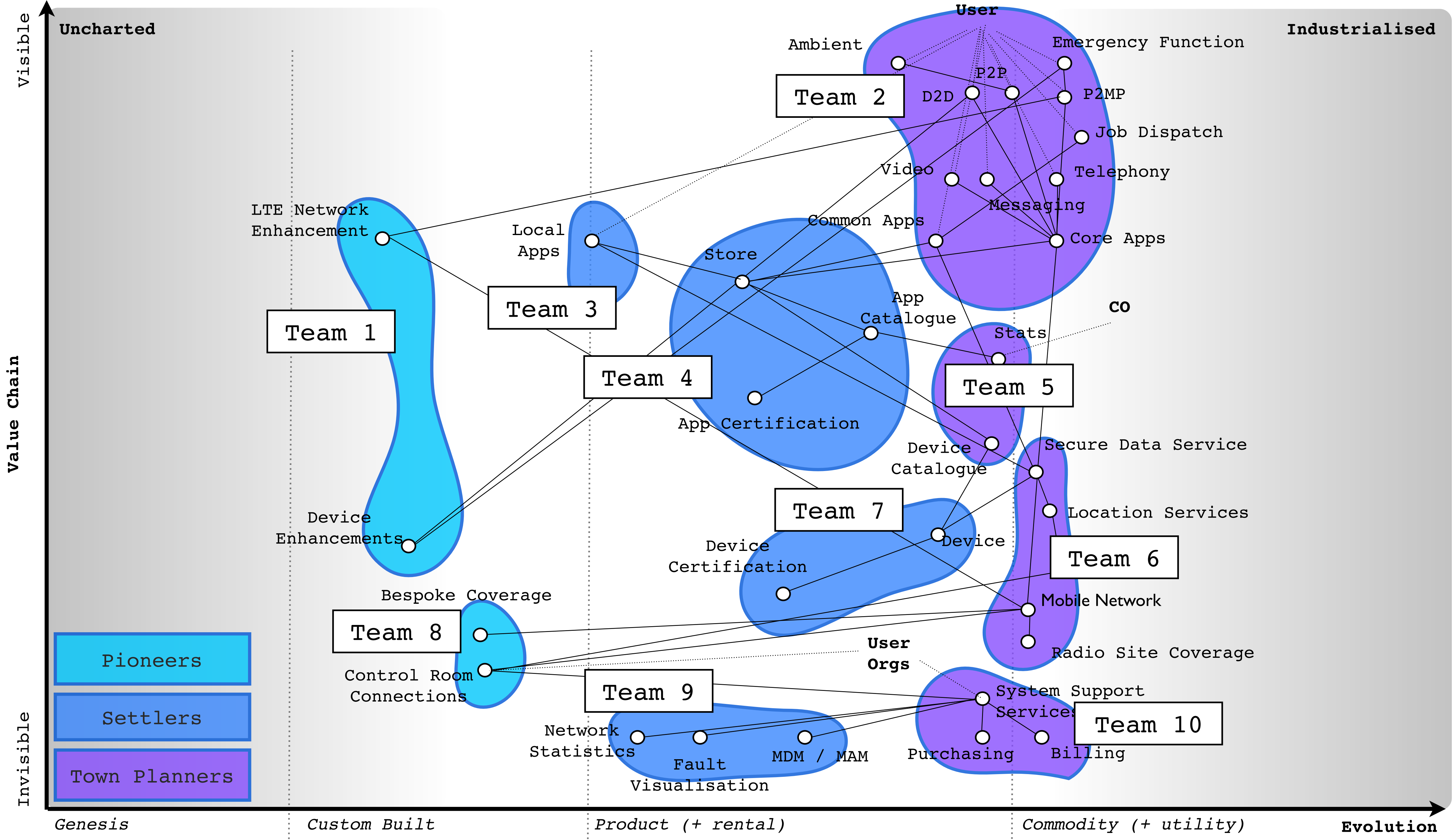



assigned, pursuant to the
the above policy to the
Insurance Com
Insurance policy.

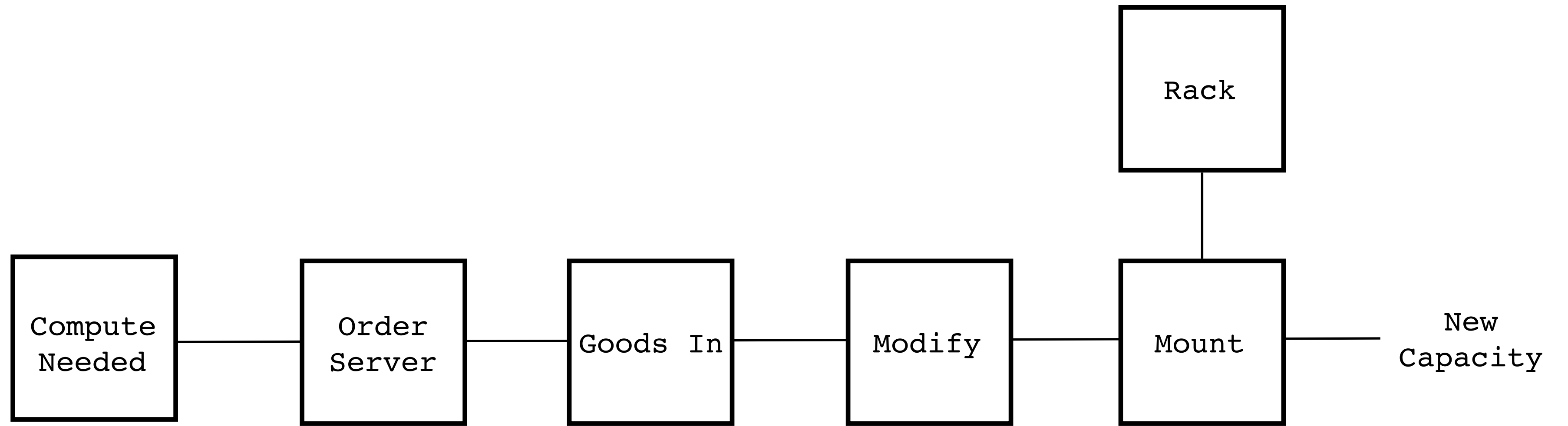

PROCESS FLOW

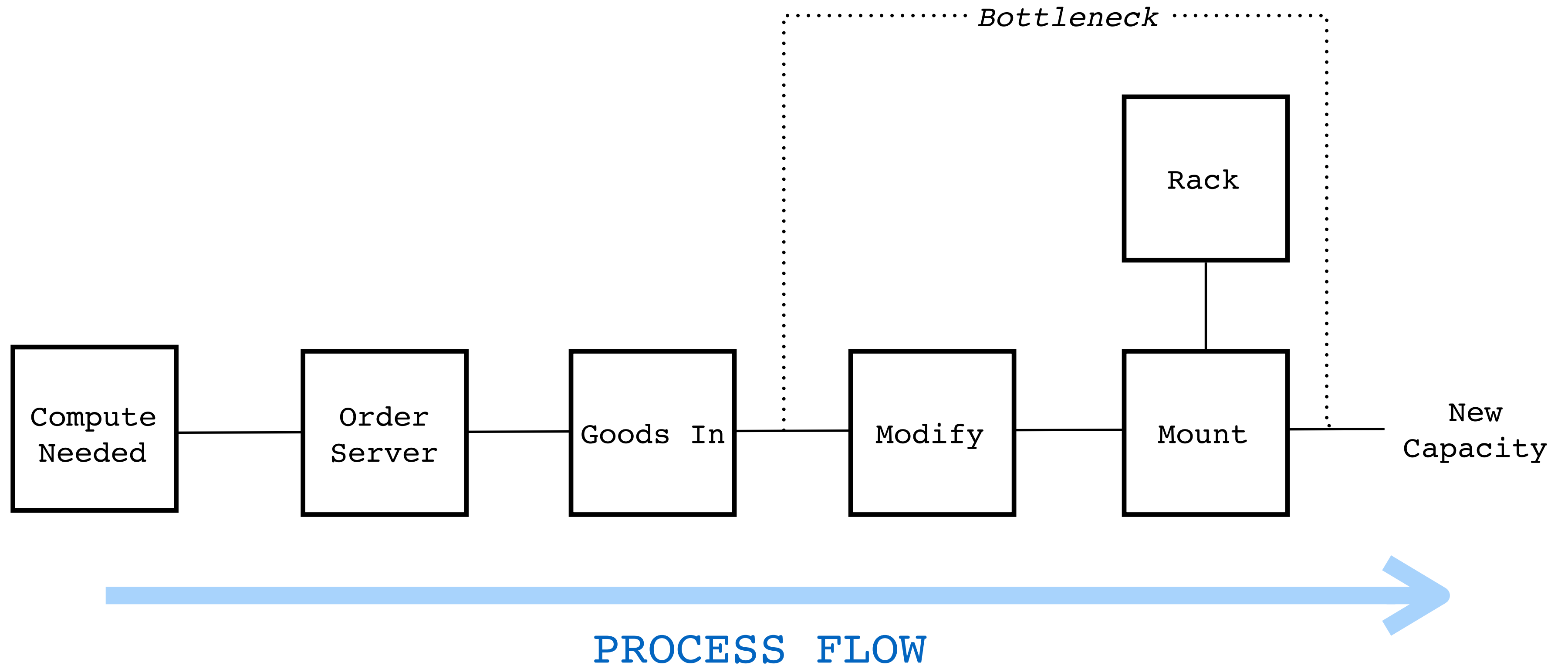

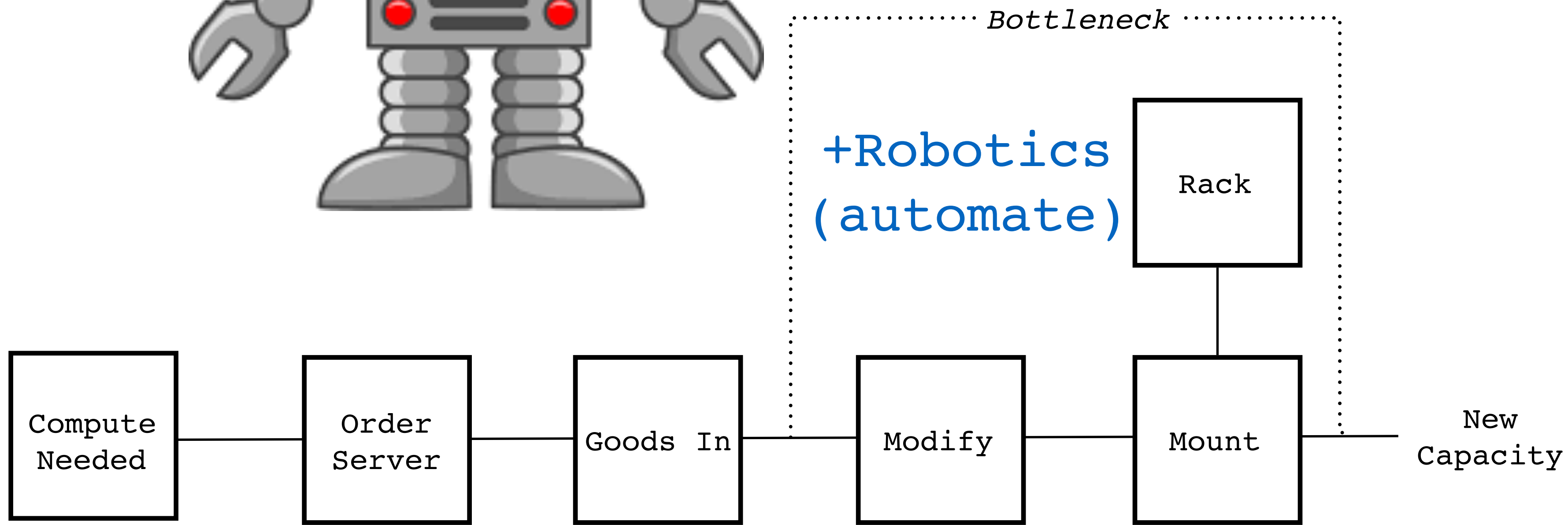
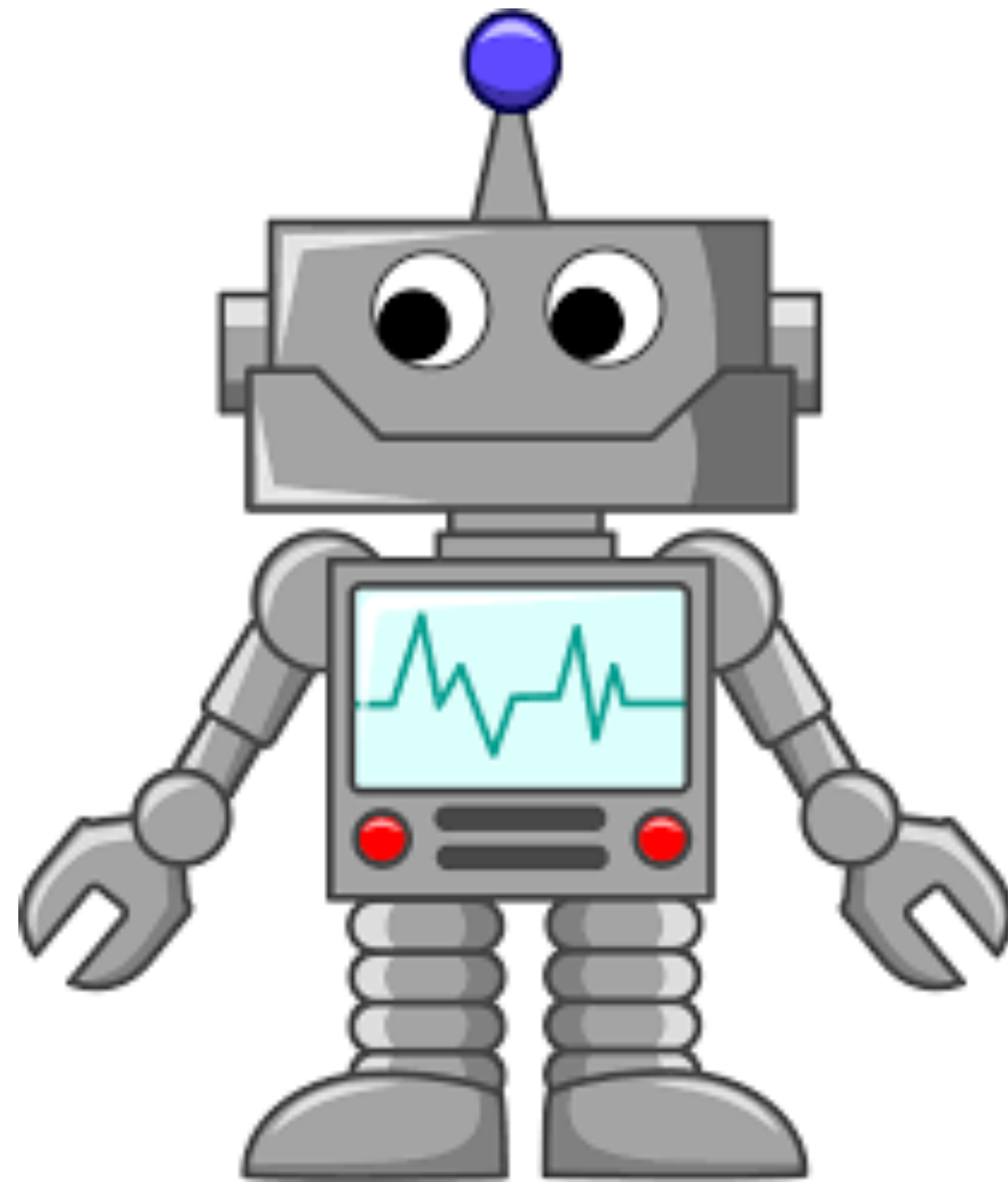

PROCESS FLOW

	Current	Robotic
Cost per install failure	US\$2,500.00	US\$2,500.00
% likelihood of failure	8.0%	0.5%
Avg cost of fail per install	US\$200	US\$13
Time to install (mins)	120	30
Labour cost per install	US\$129	US\$11
Annual number of install	8,000	8,000
Total annual cost of Install	US\$1,028,571	US\$85,714
Total annual cost of failures	US\$1,600,000	US\$100,000
Total annual cost	US\$2,628,571	US\$185,714
Investment / Capex	US\$0	US\$2,000,000
ROI		< 1 year

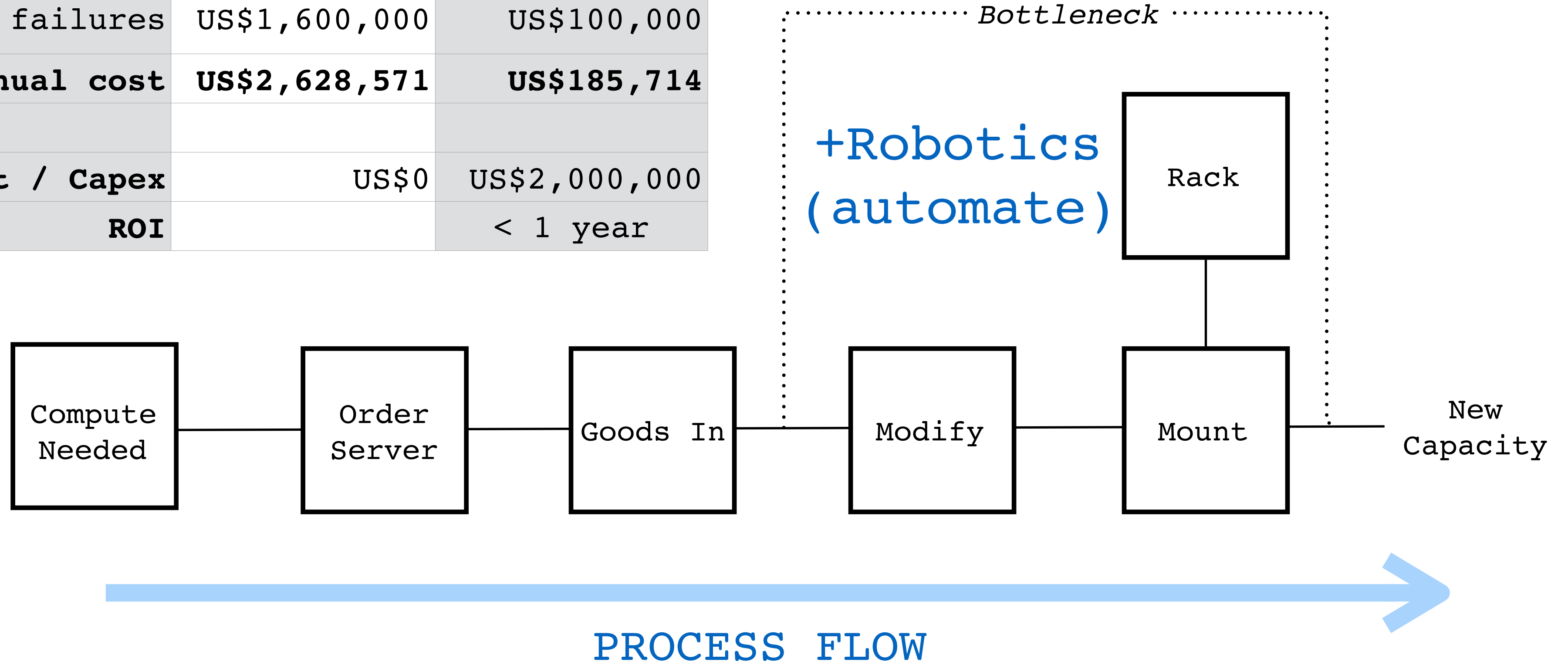

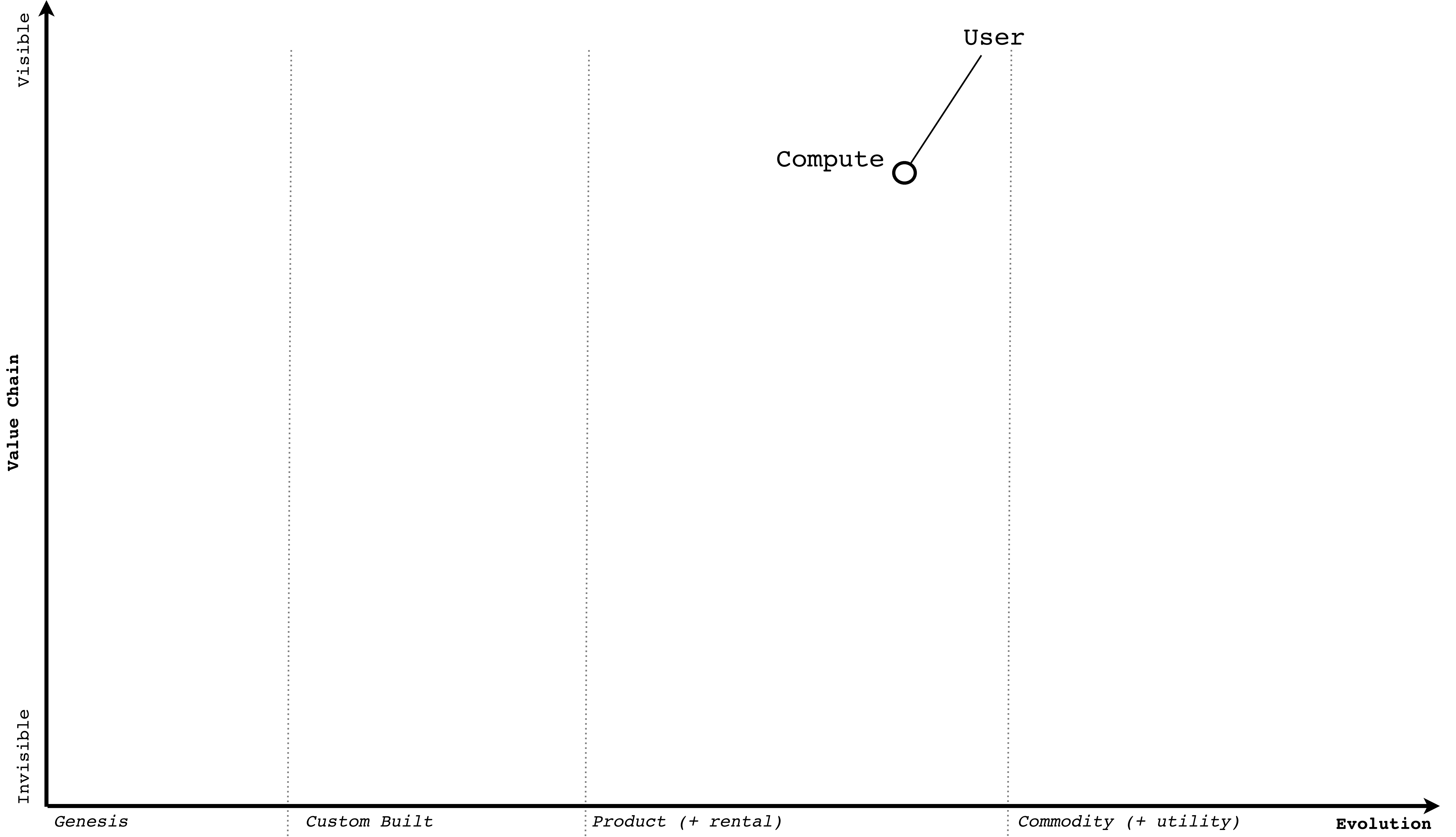

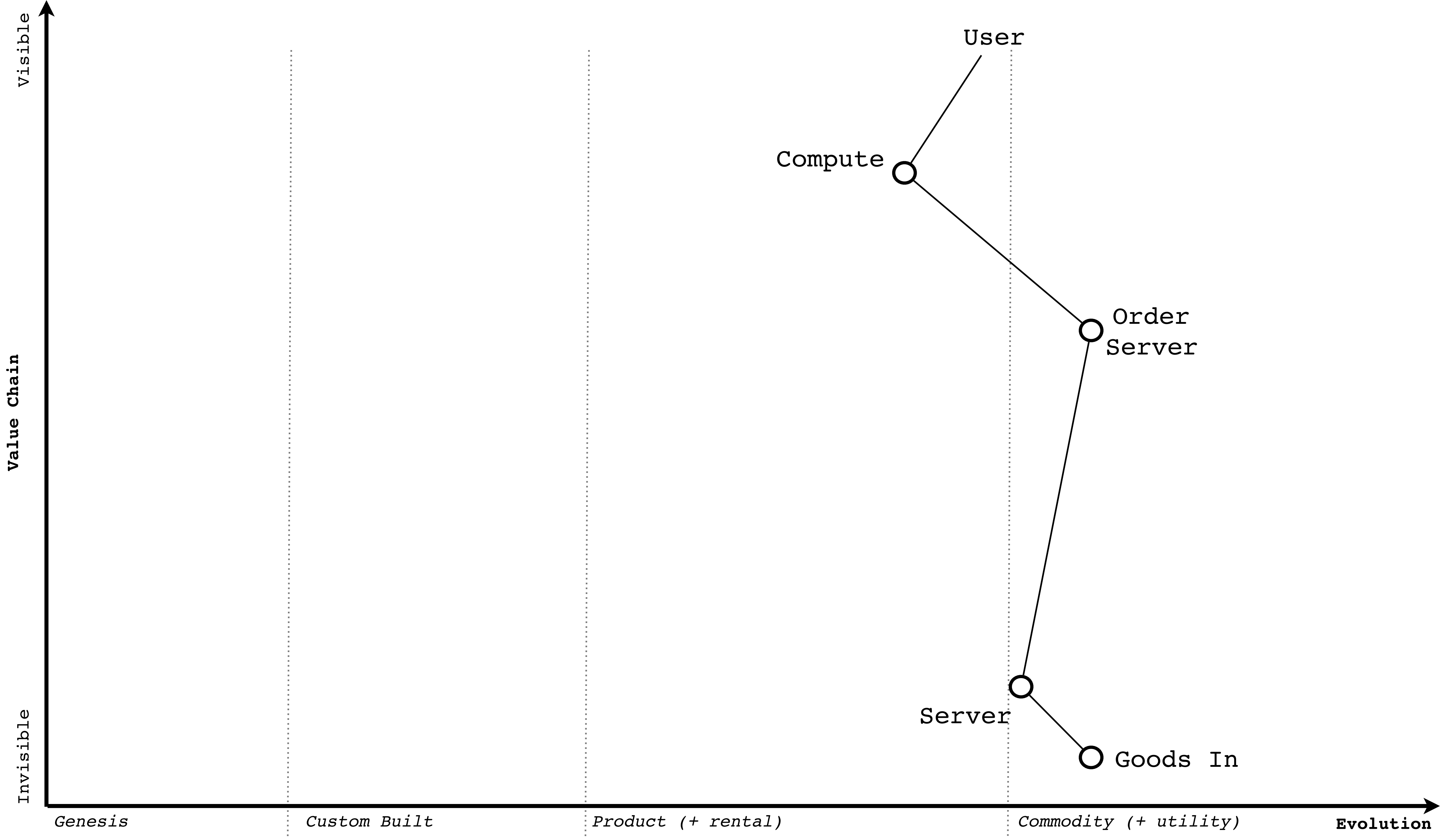

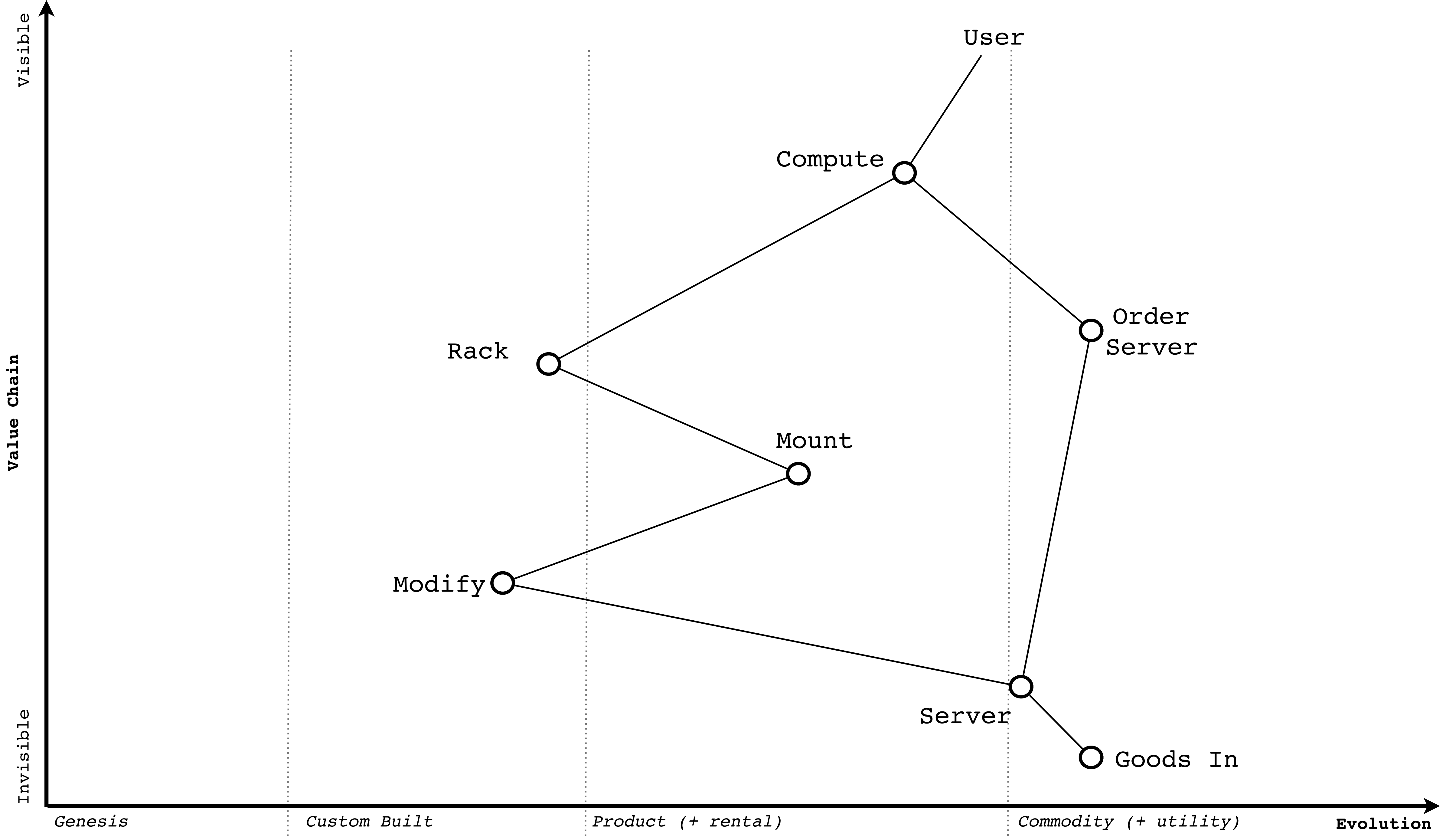

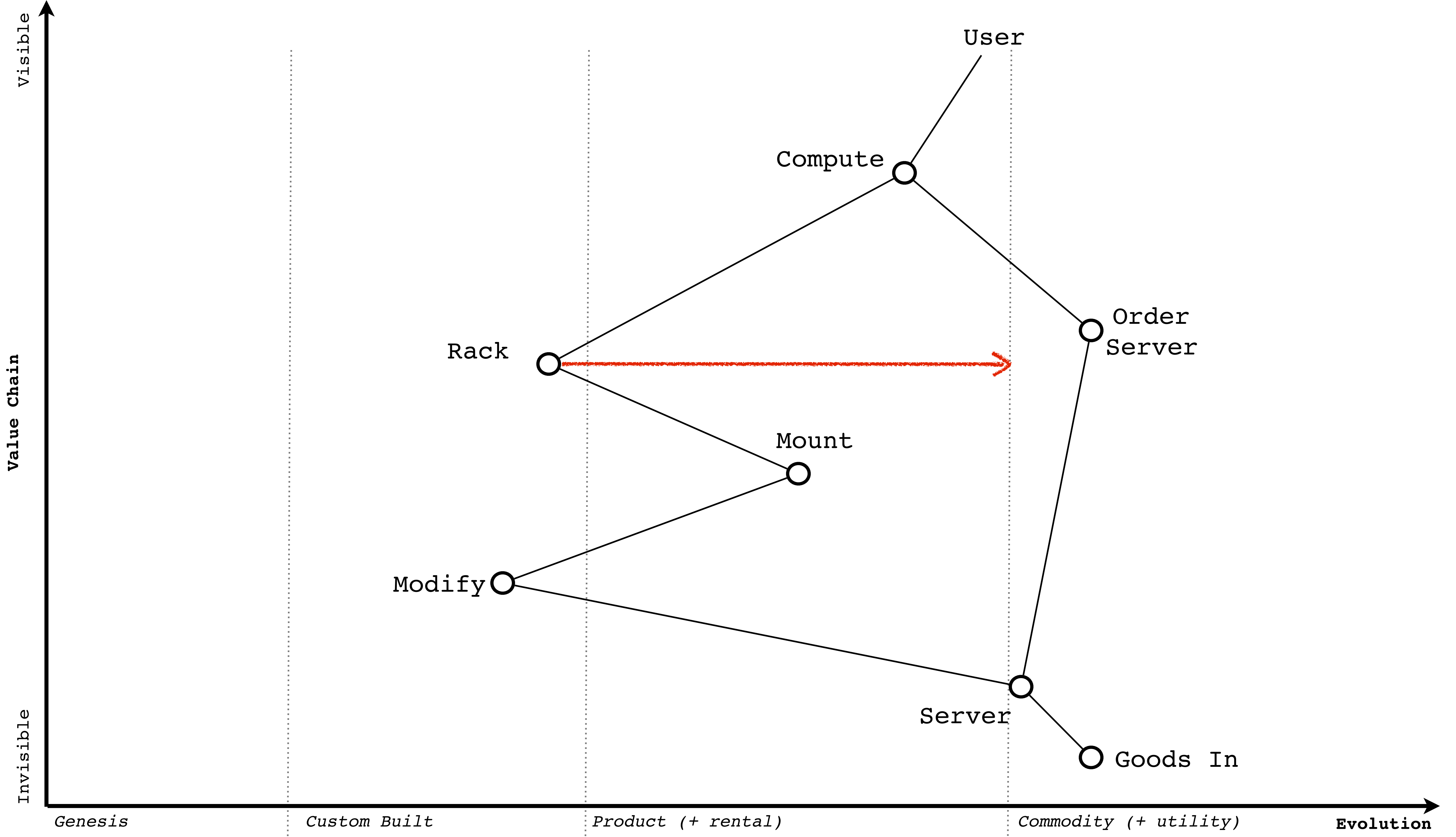

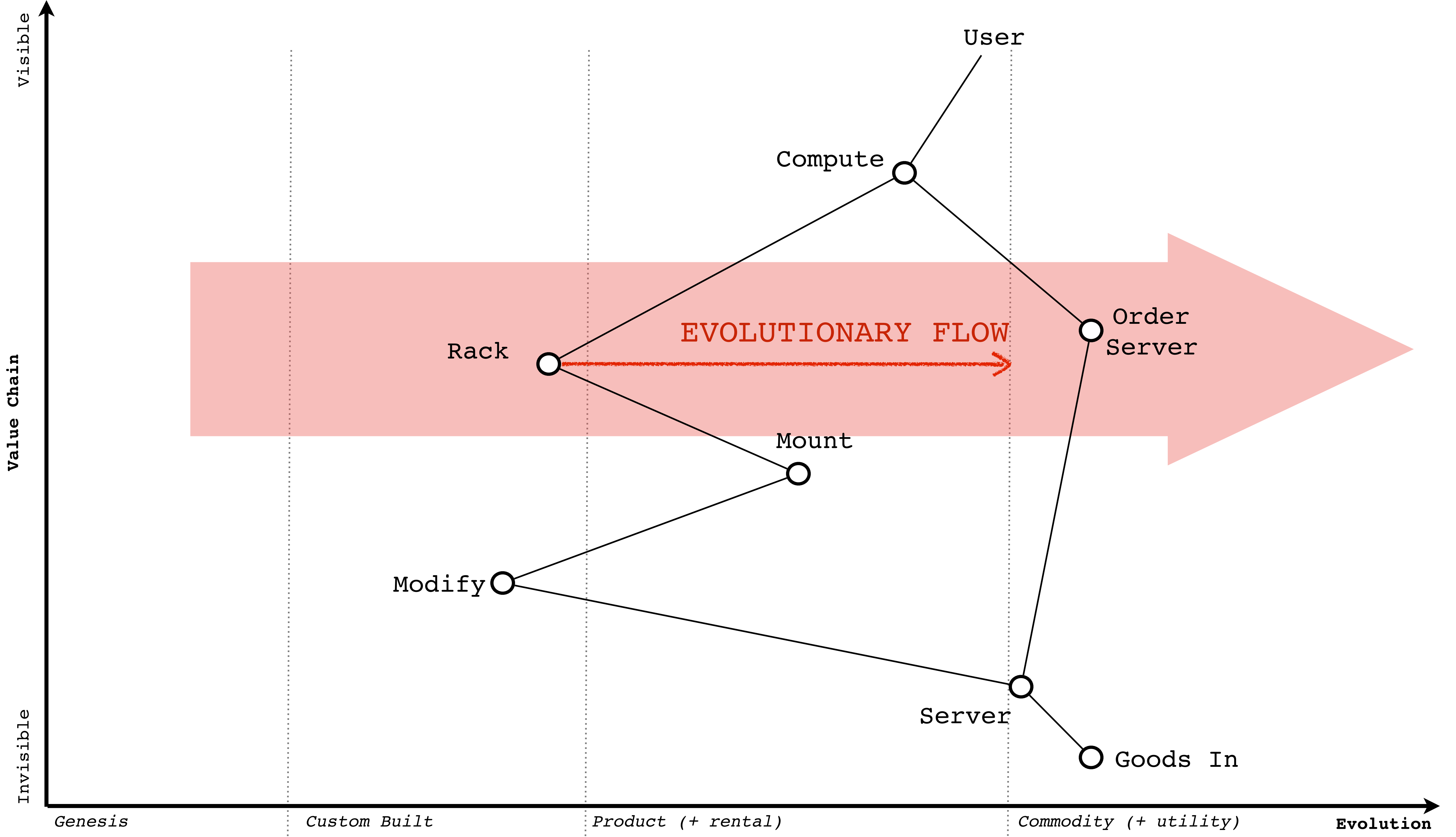

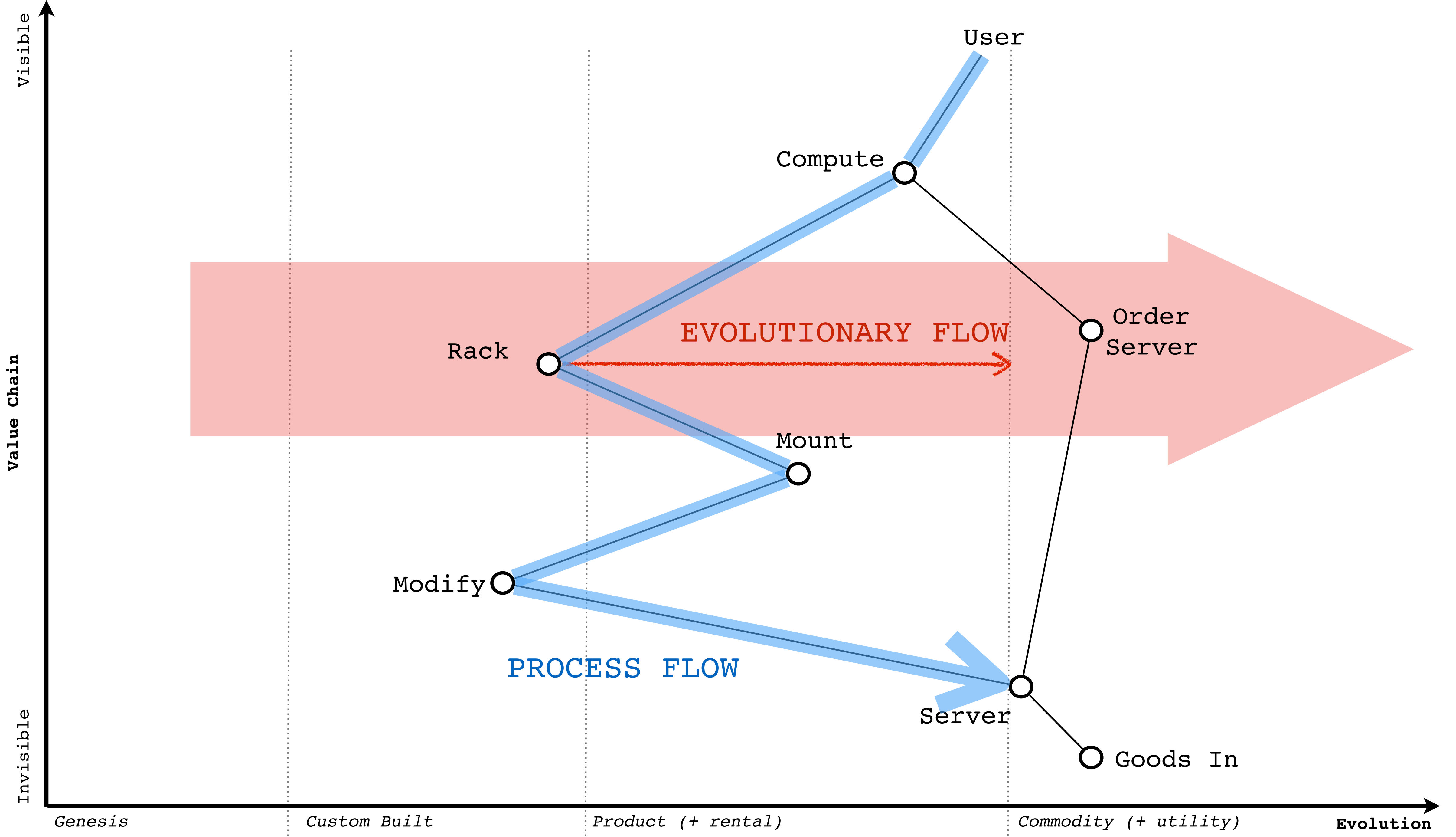

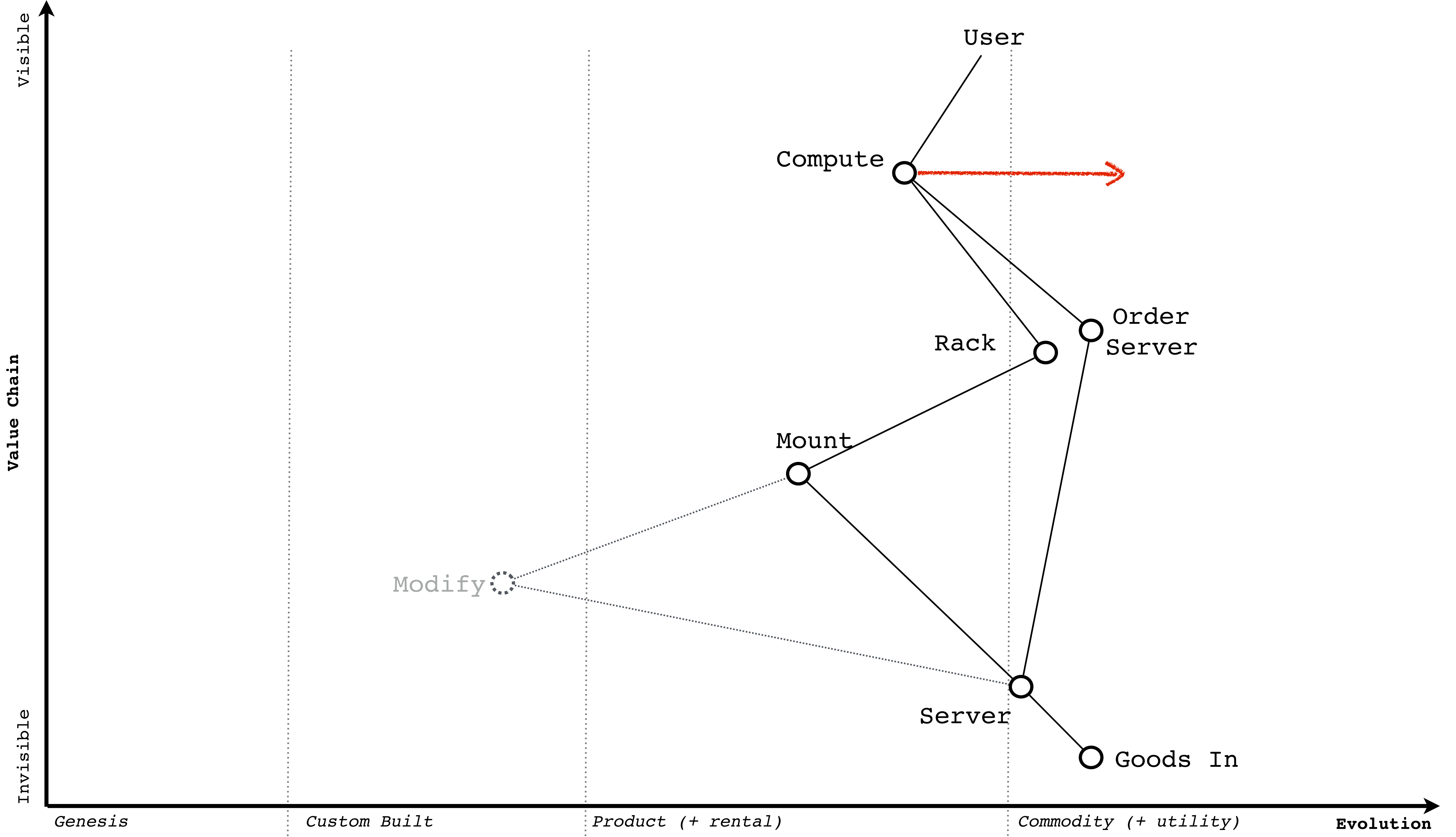

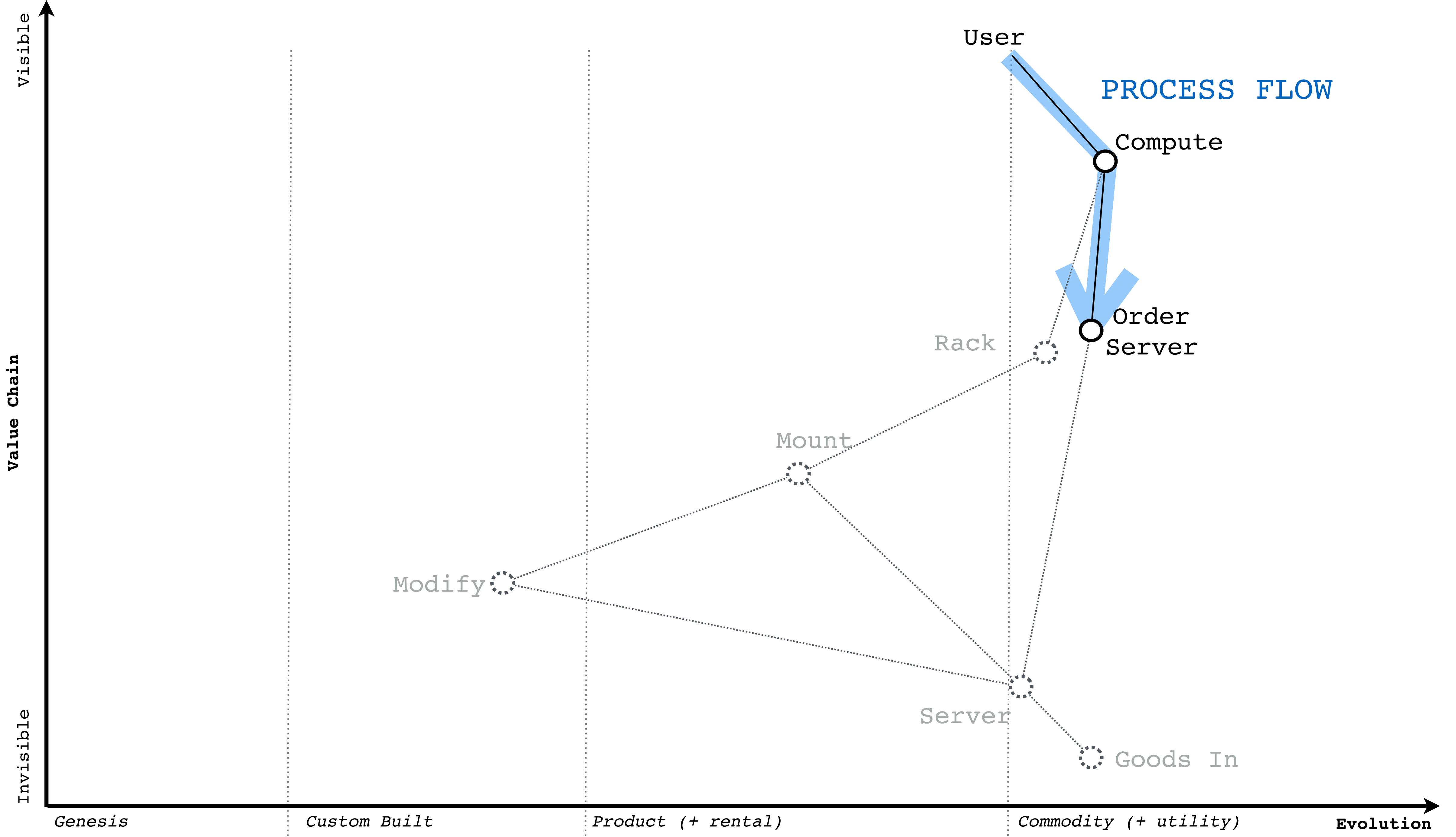

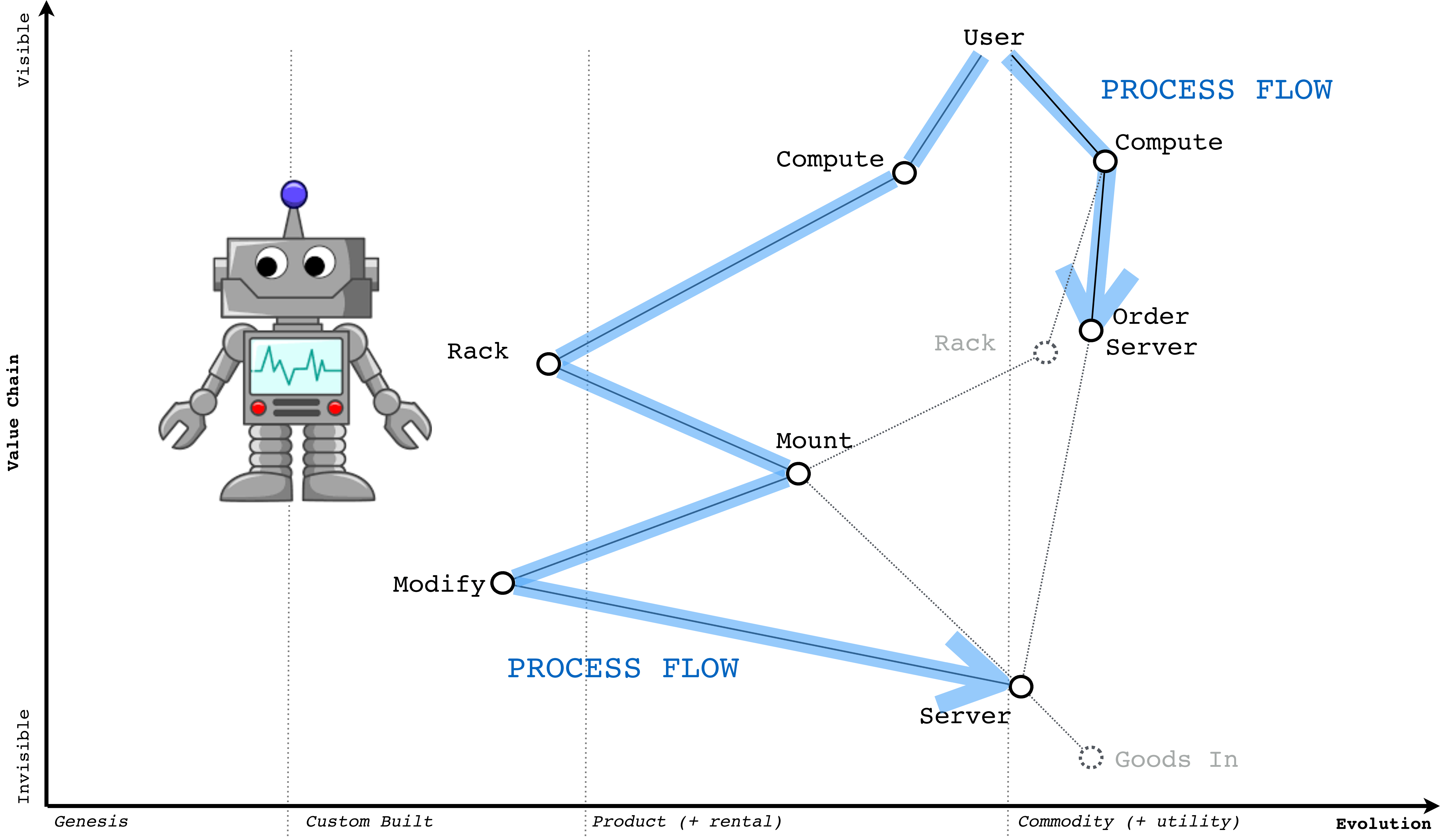



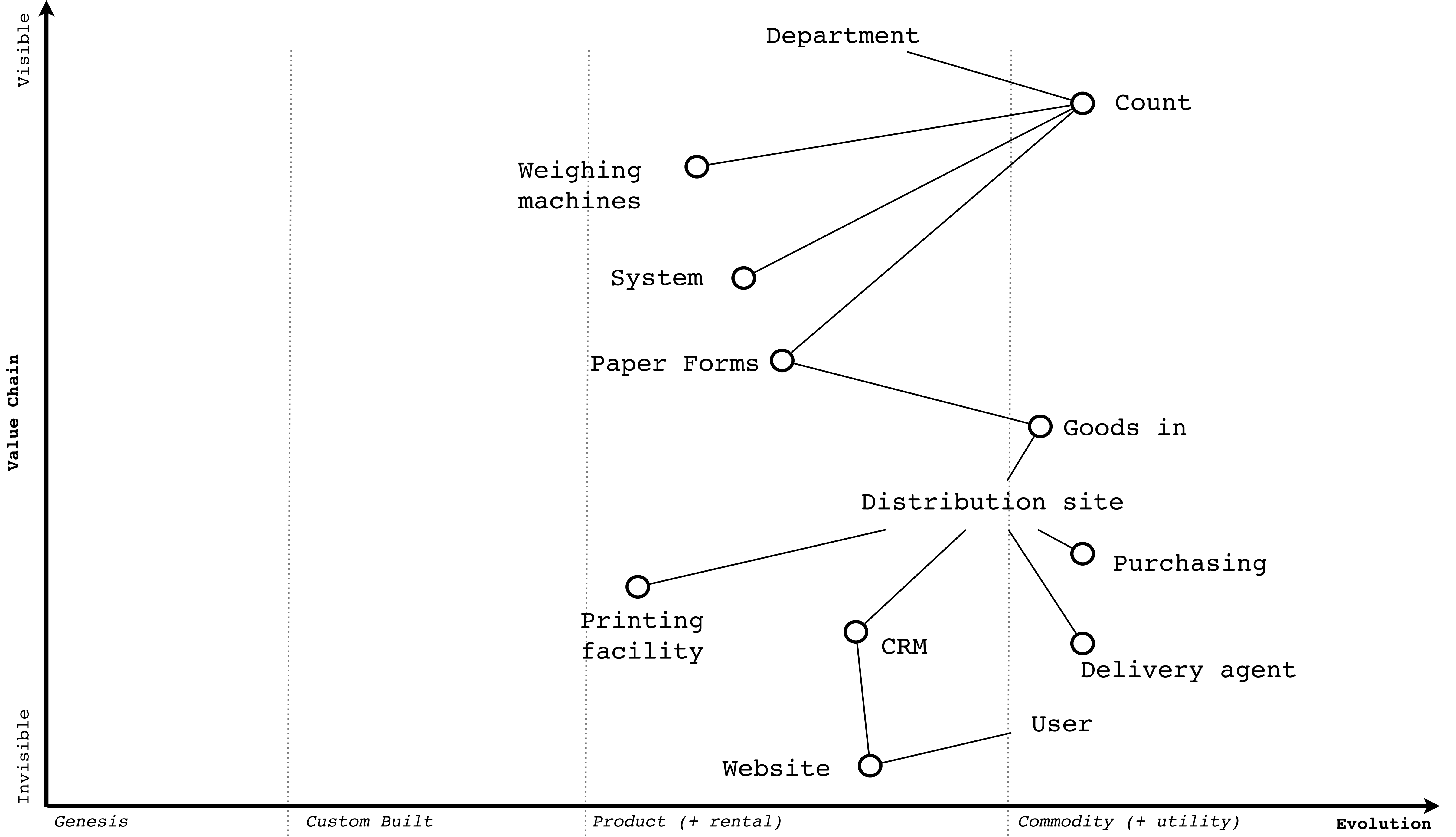

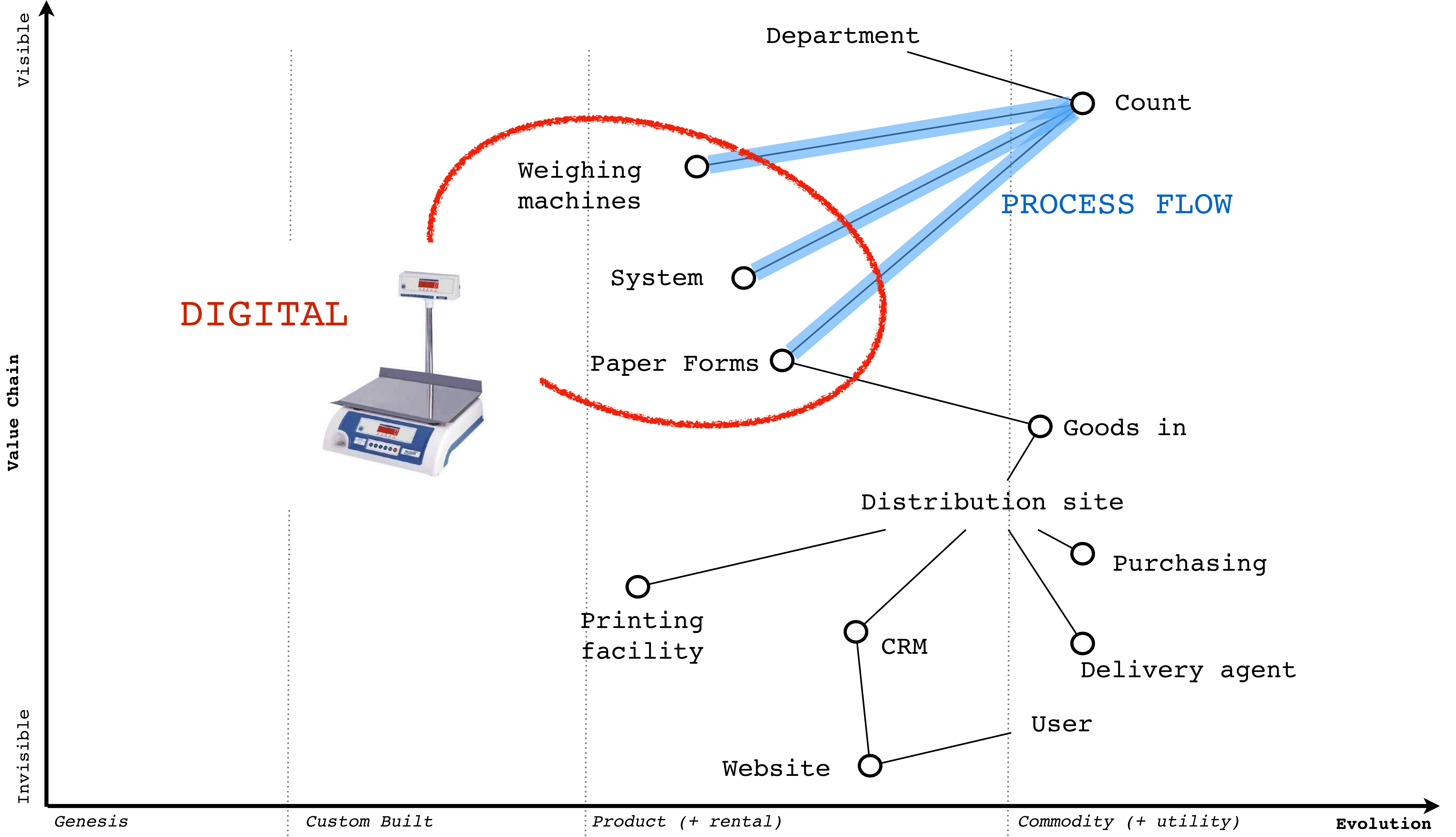

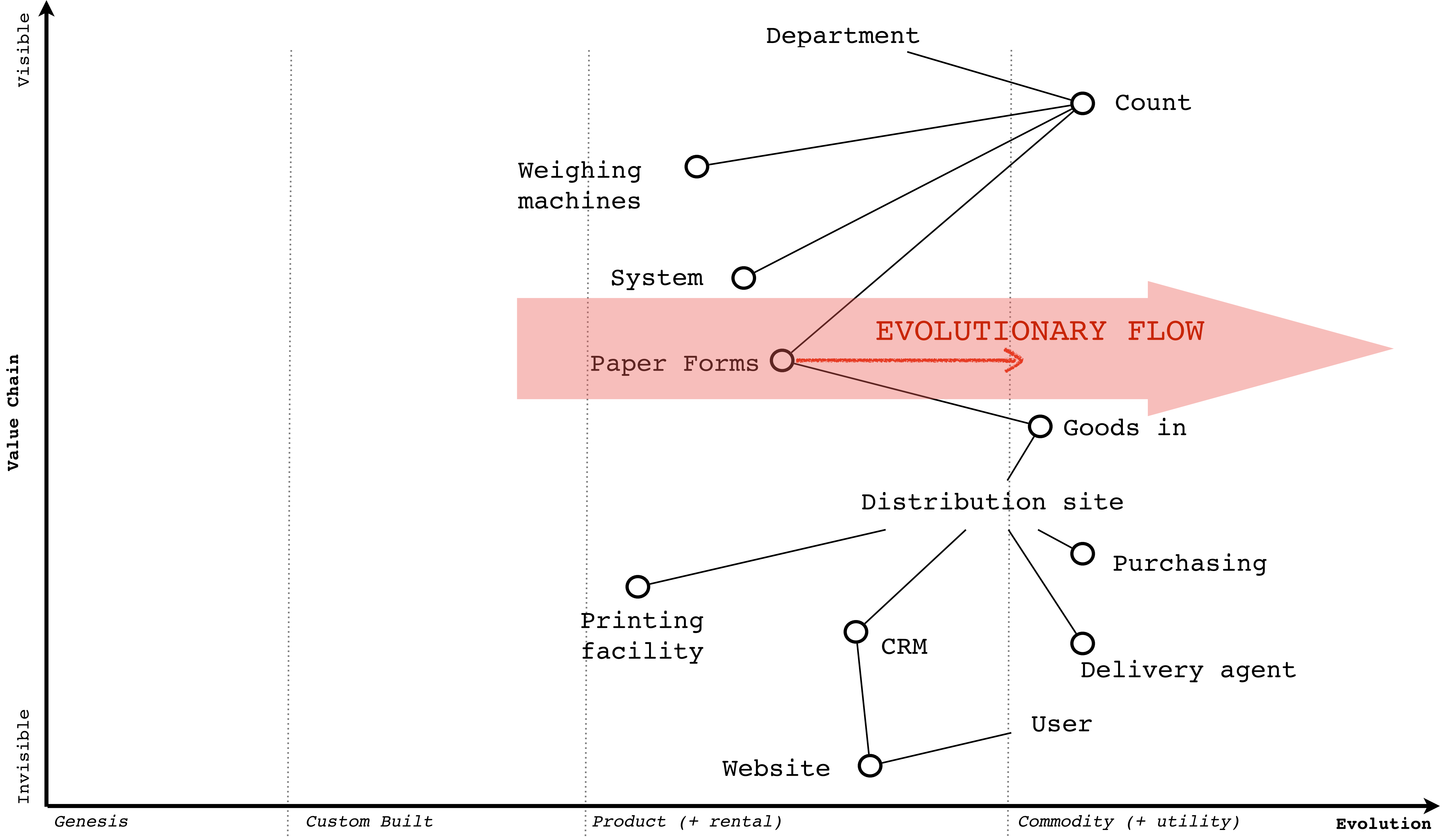

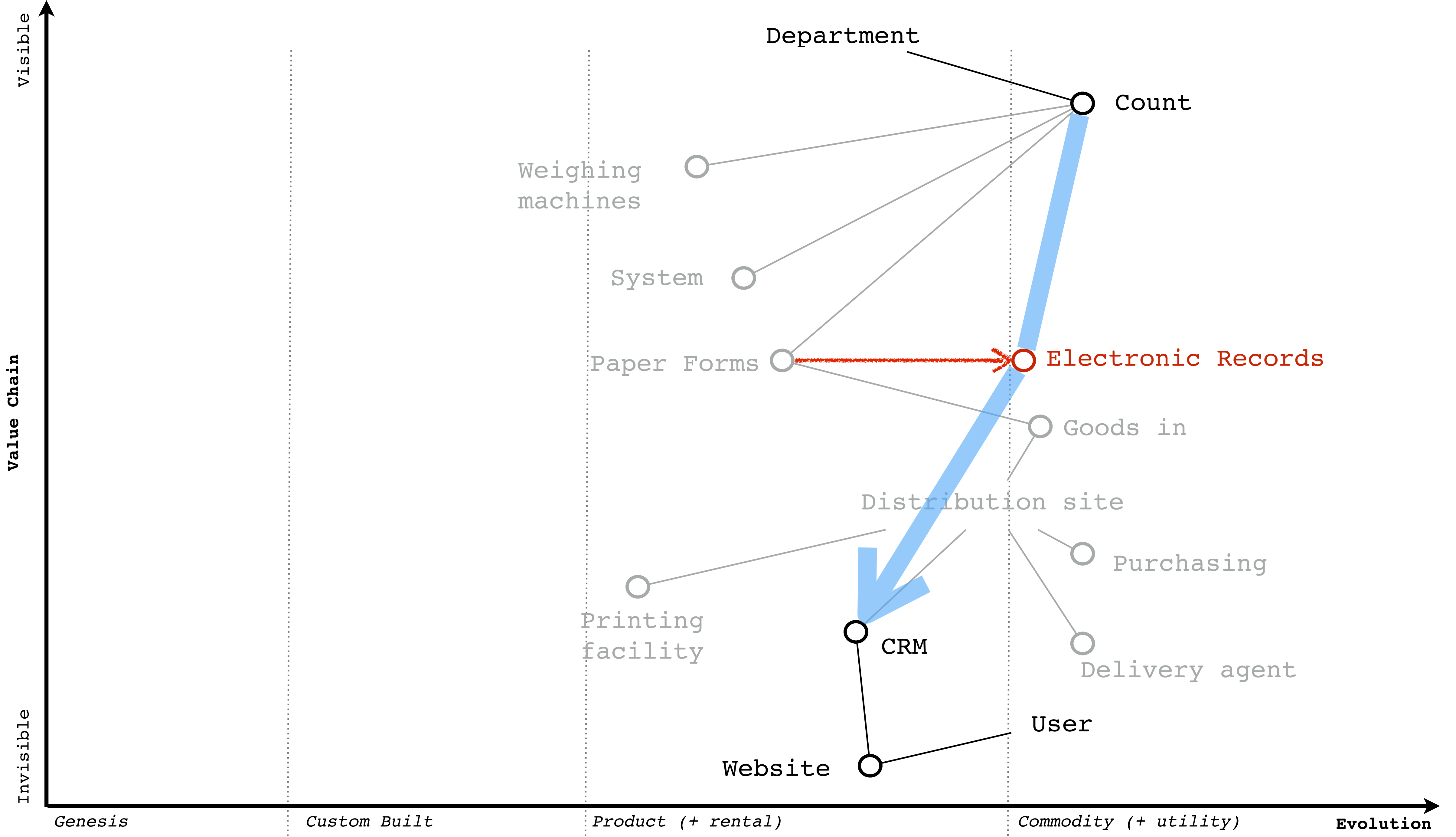

Strategy



Maps

Communication



Patterns

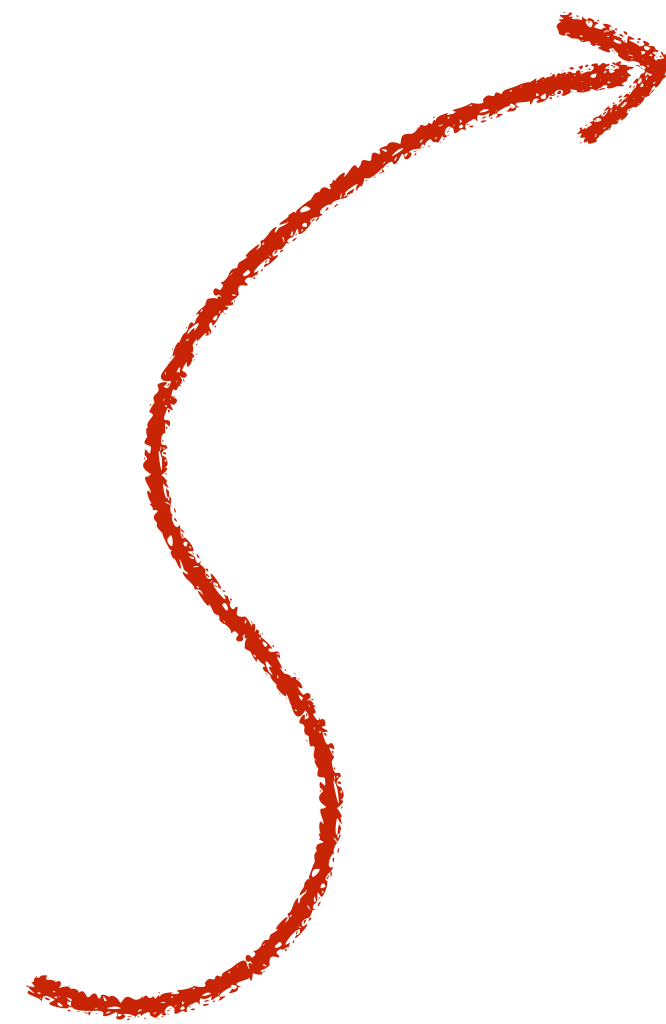

Anticipation

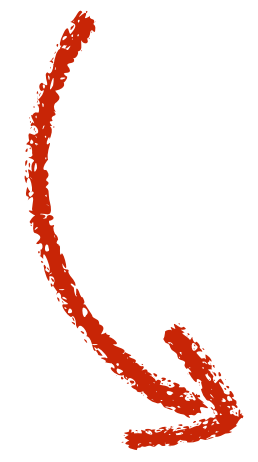

Organisation



Leadership

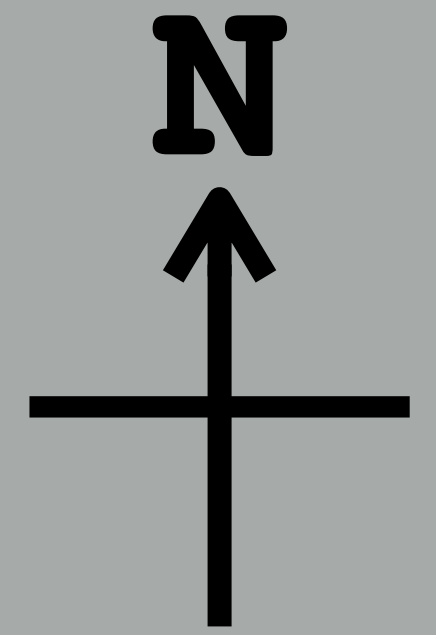
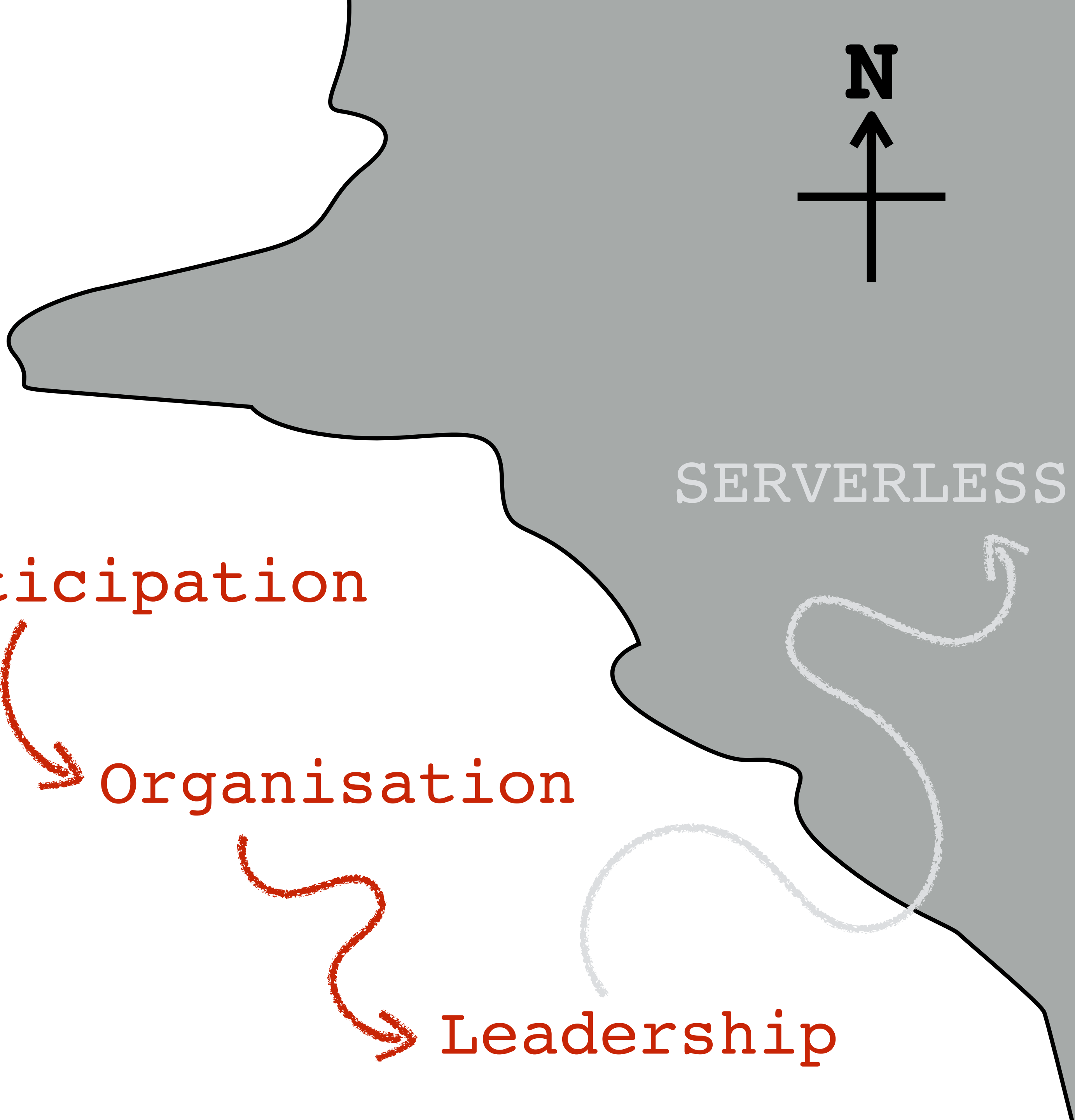

SERVERLESS

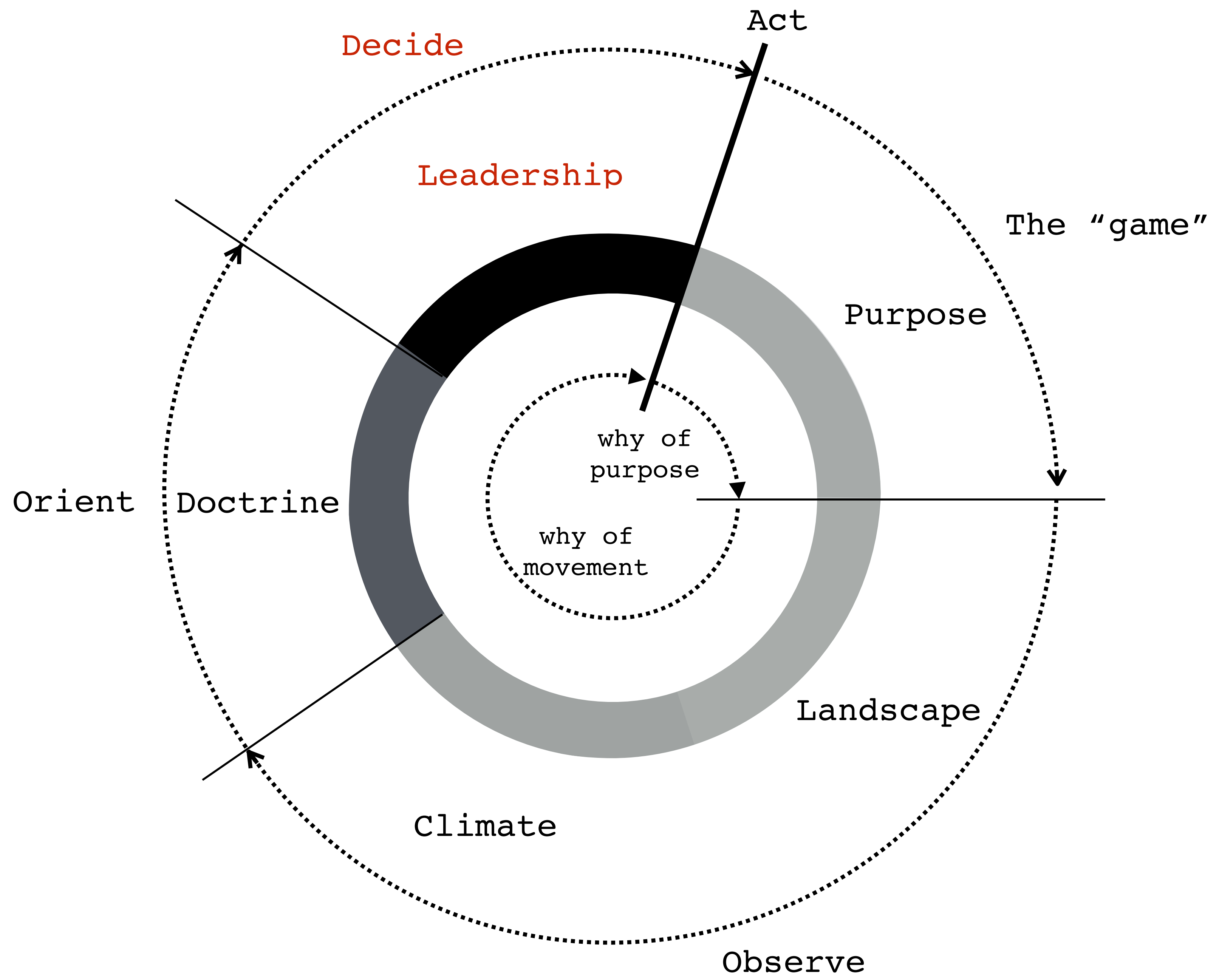

Strategy

Context specific forms
of gameplay

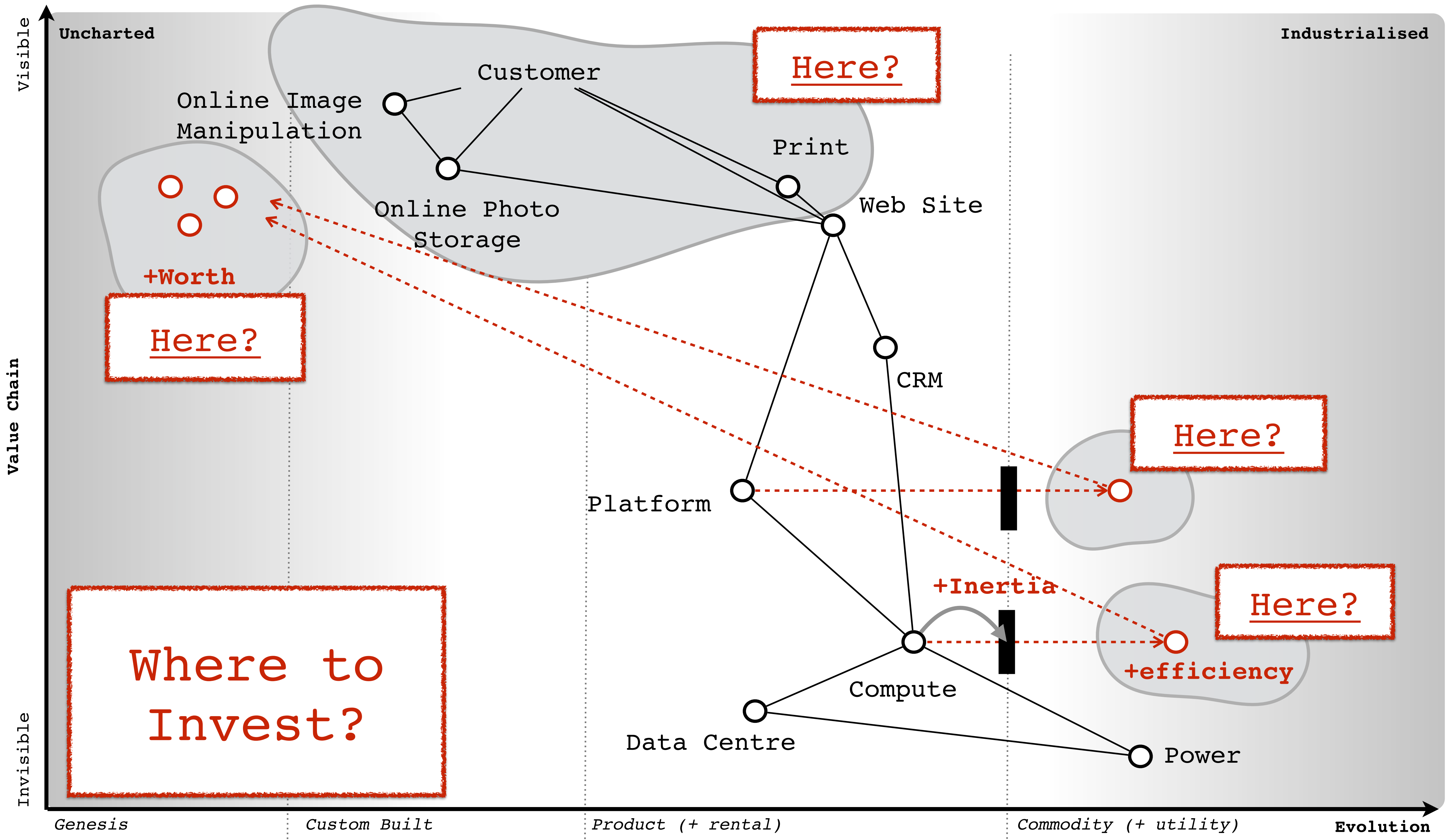

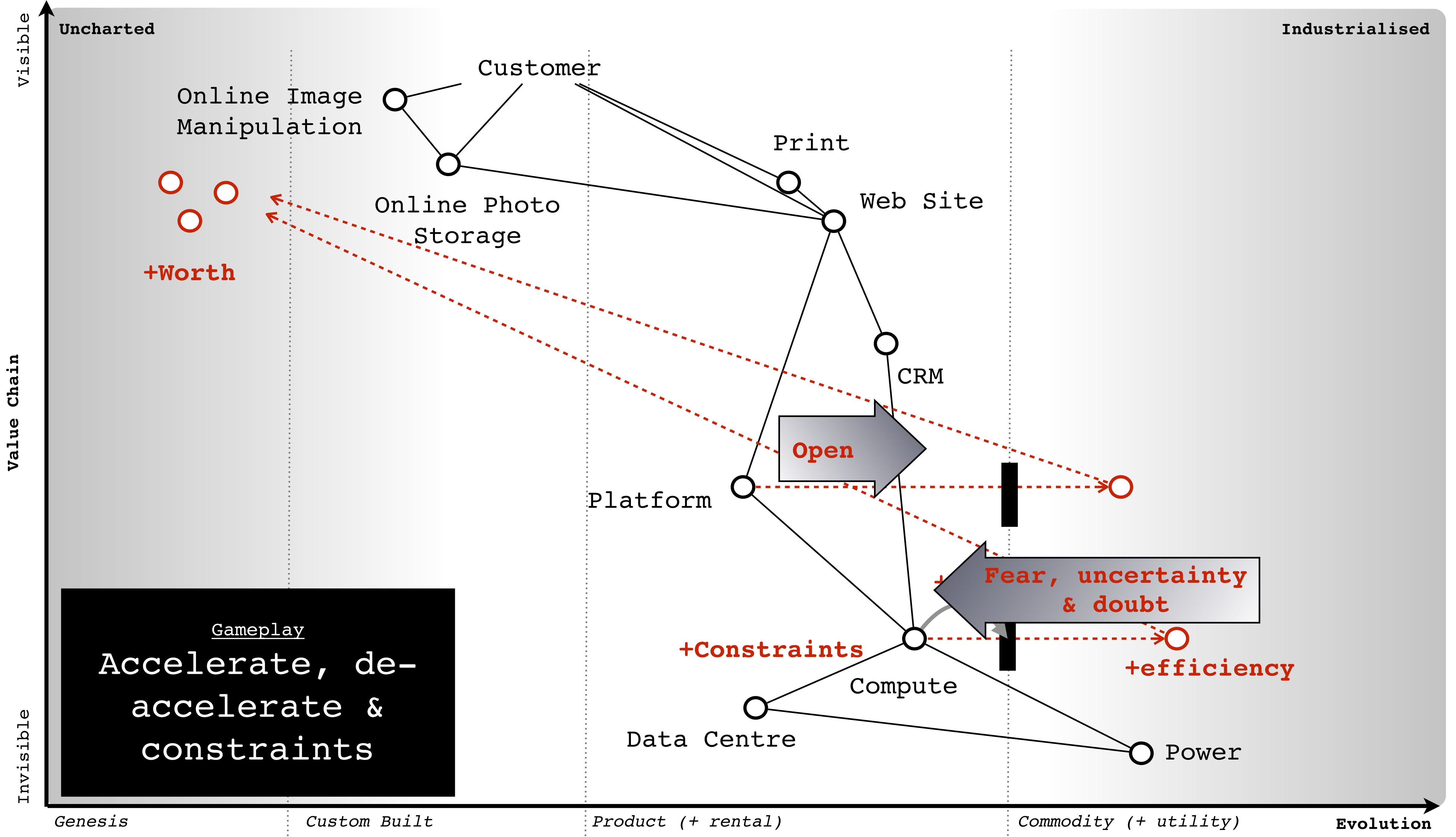

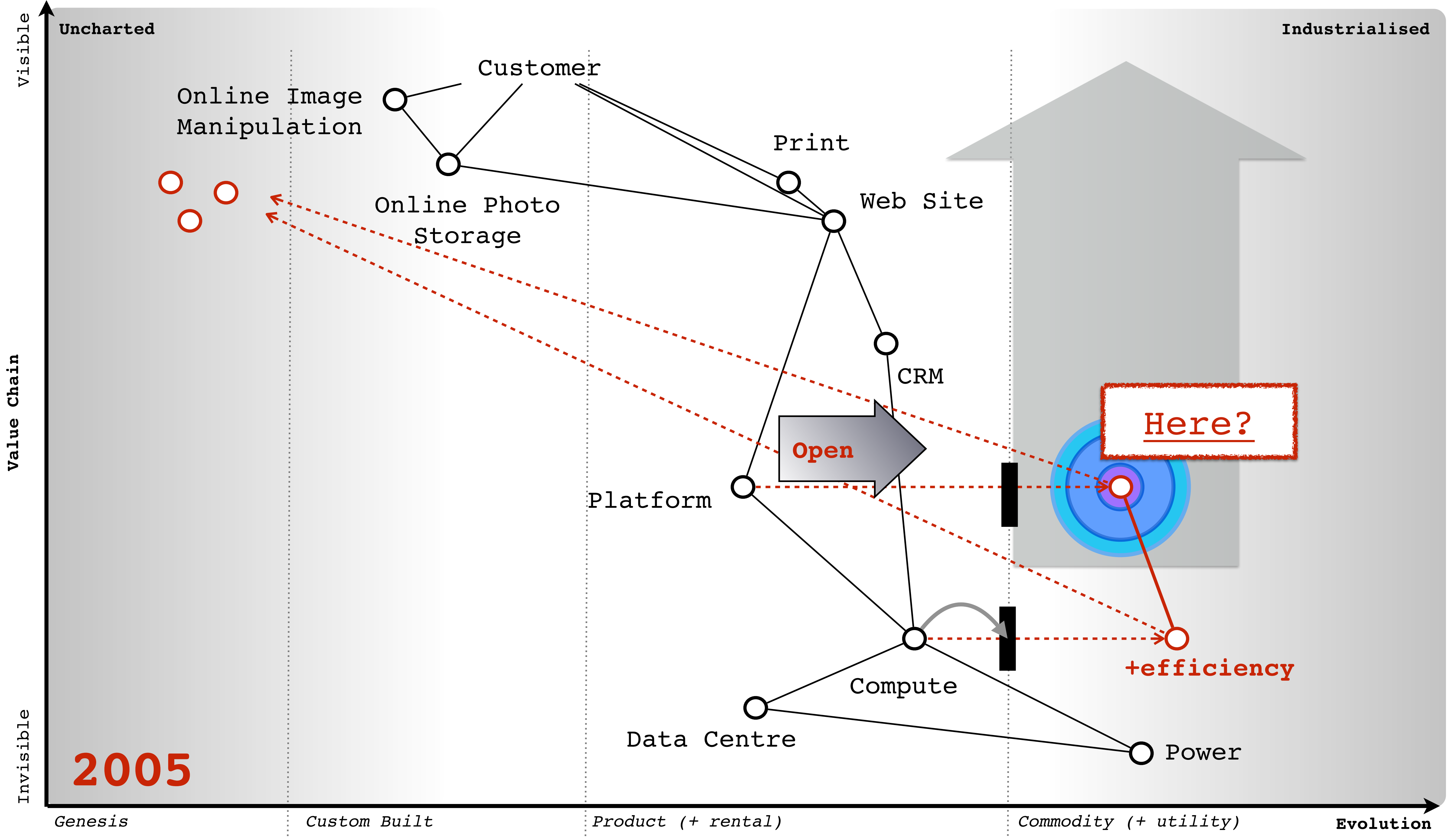

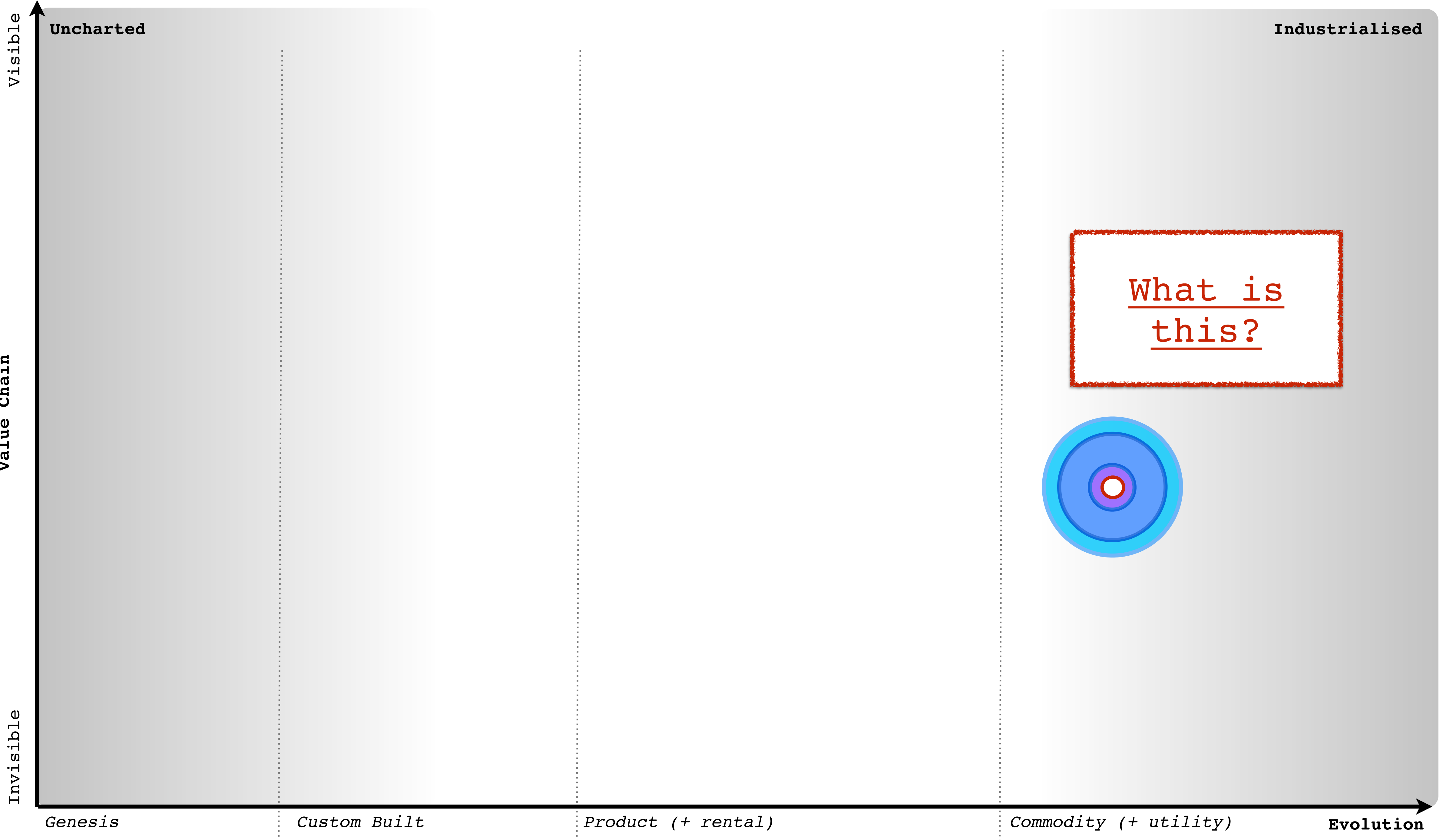

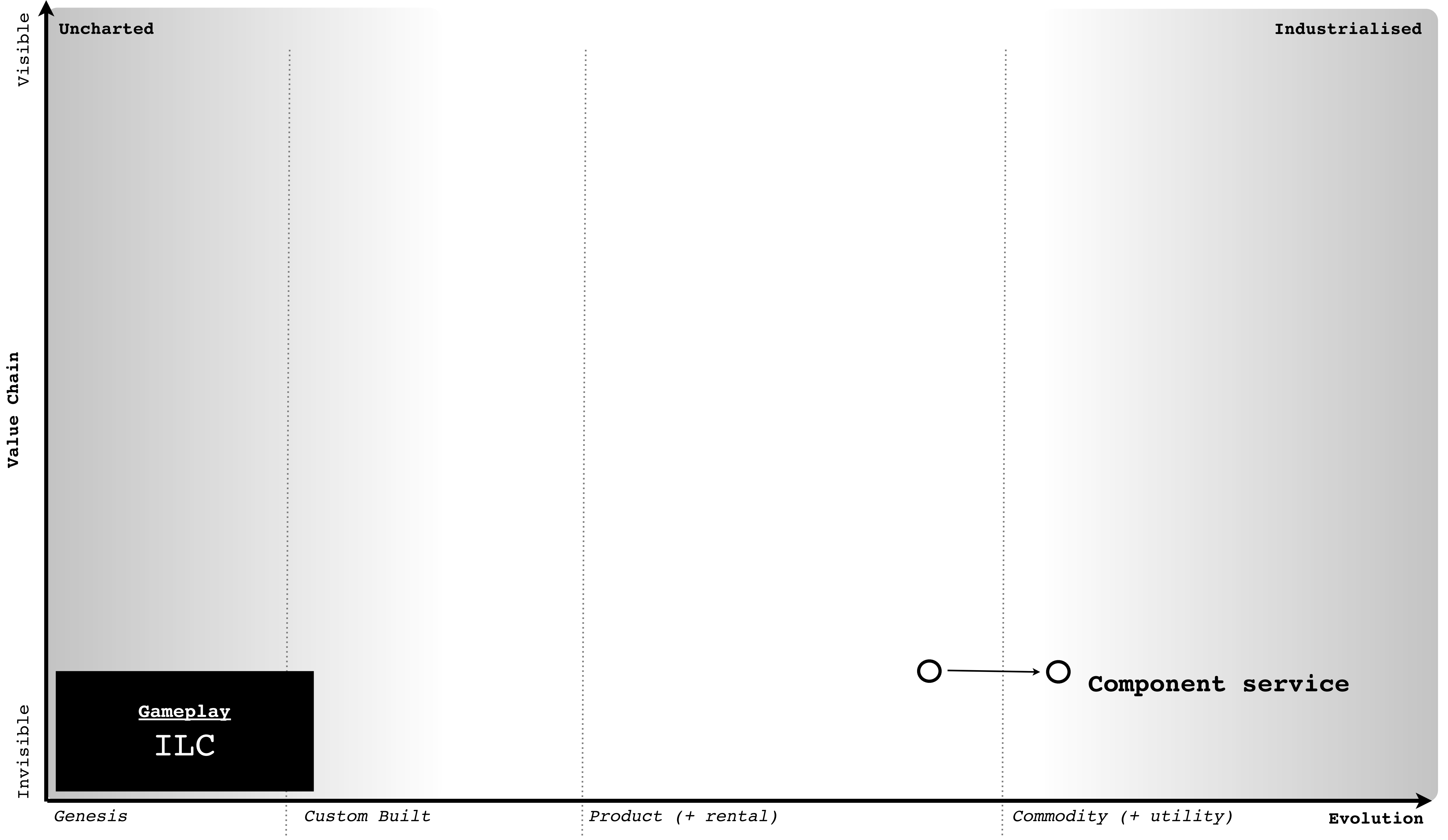

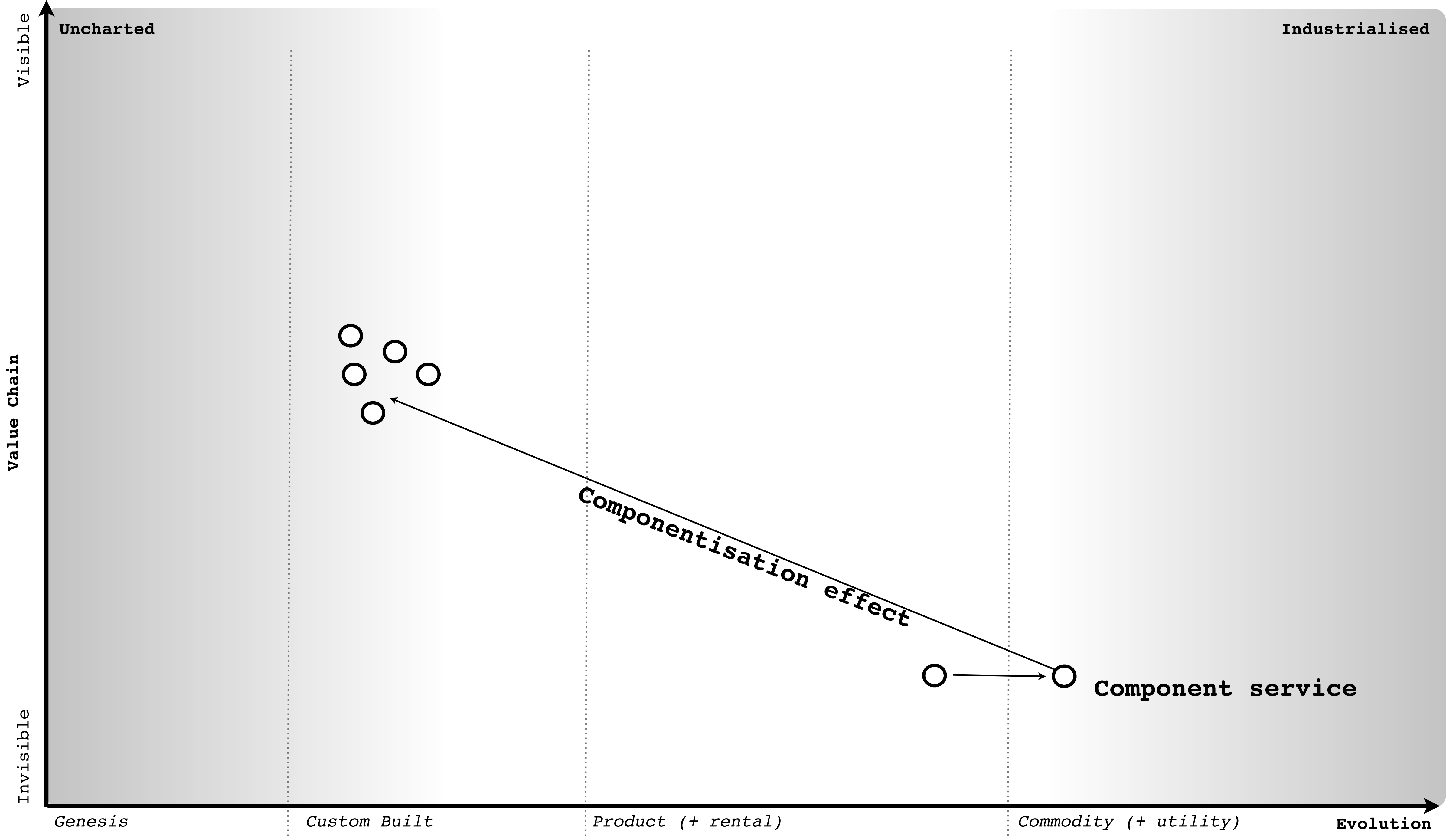

Uncharted

Industrialised

Visible

Value Chain

Invisible

Genesis

Custom Built

Product (+ rental)

Commodity (+ utility)

Evolution

Componentisation effect

Component service

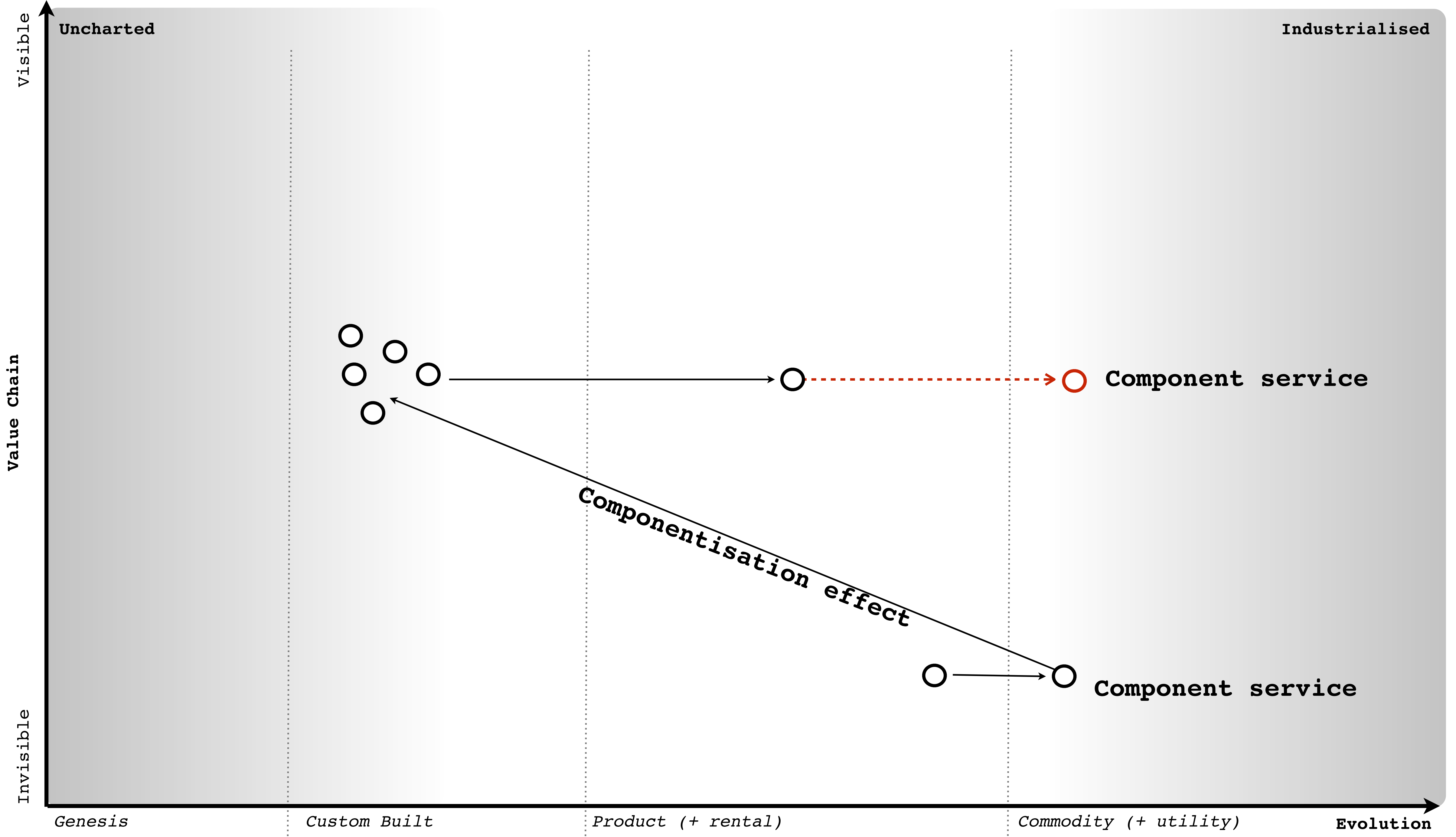

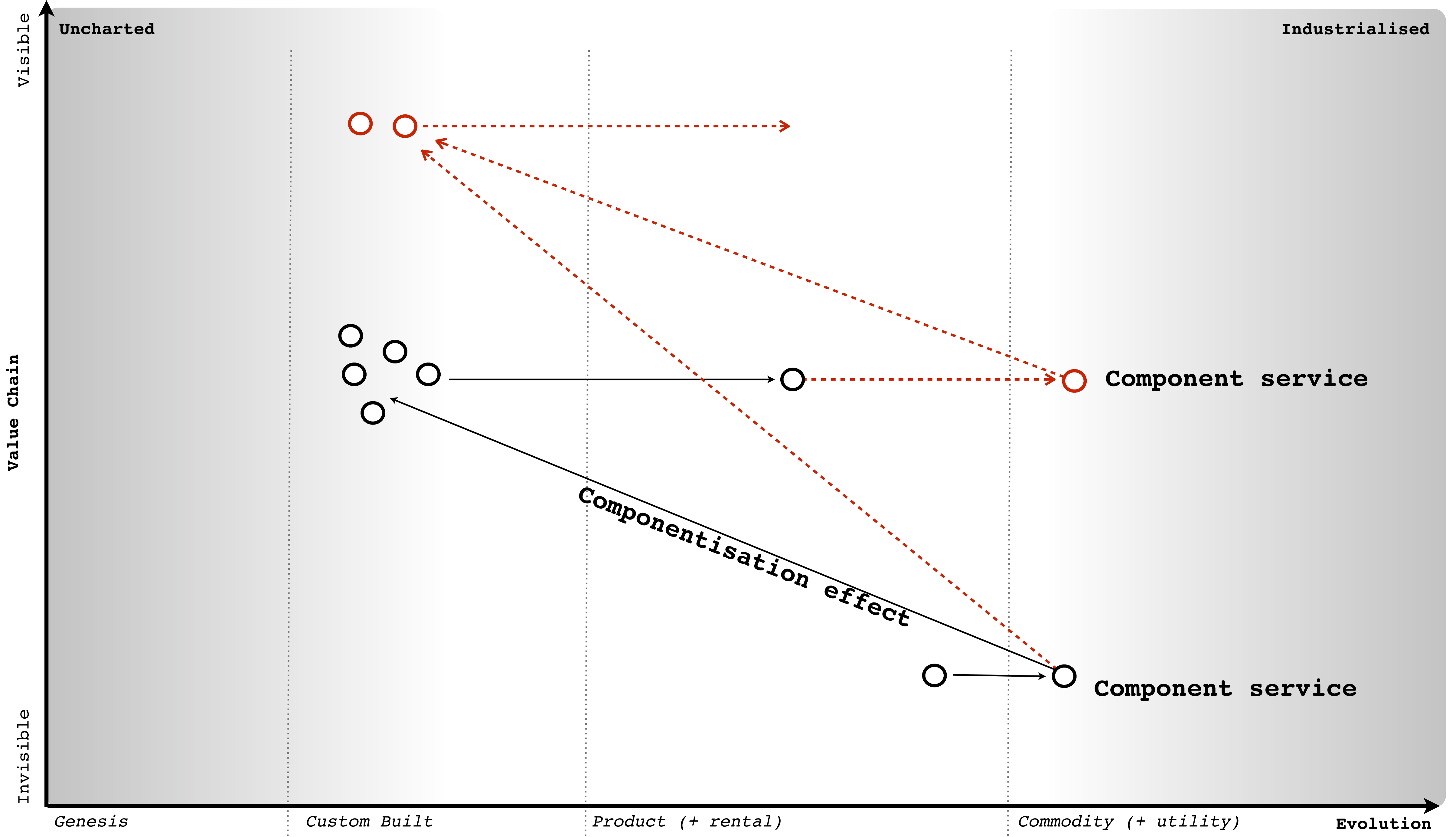

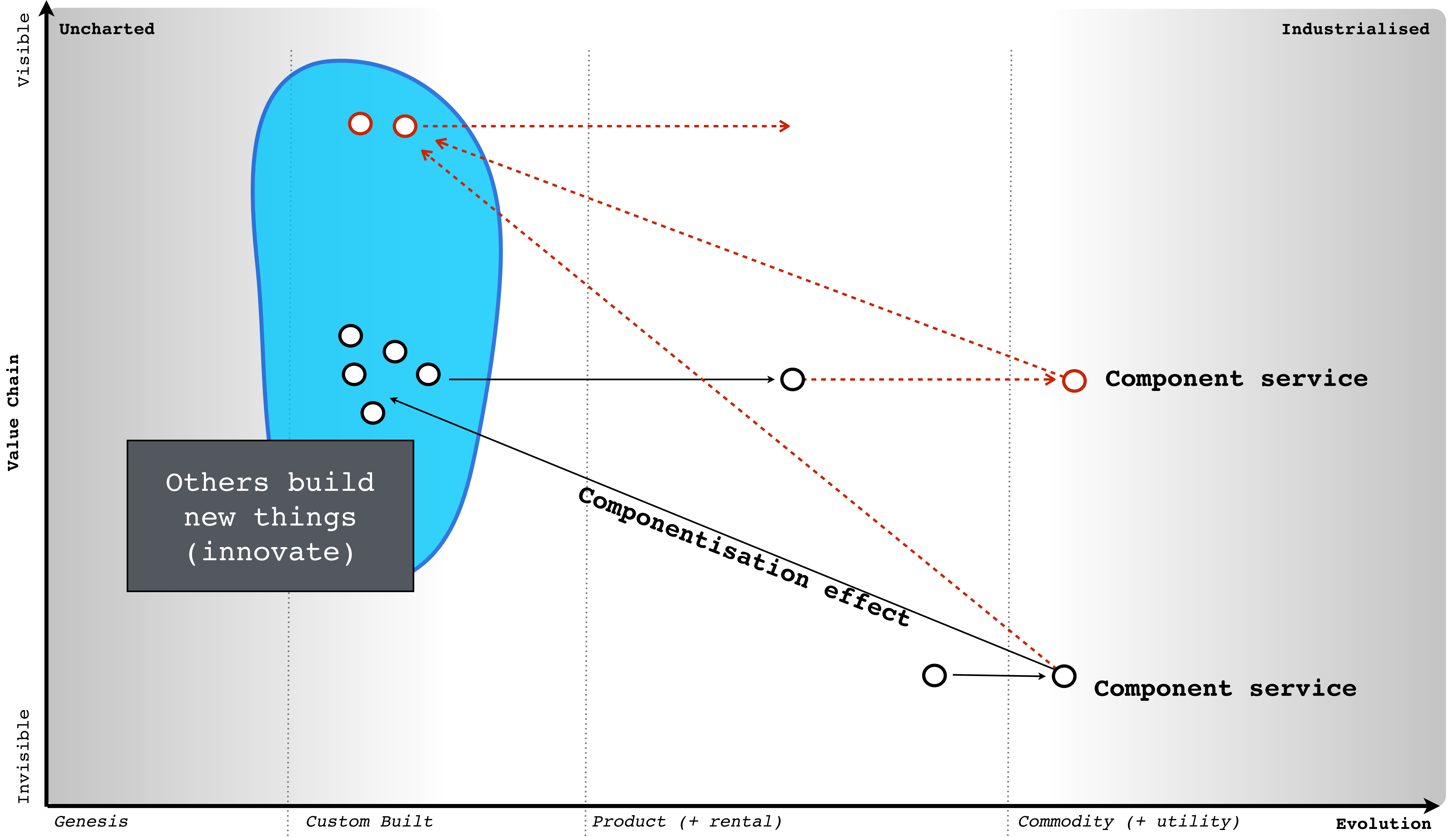

Uncharted

Industrialised

Visible

Value Chain

Invisible

Others build
new things
(innovate)

Componentisation effect

Component service

Component service

Genesis

Custom Built

Product (+ rental)

Commodity (+ utility)

Evolution

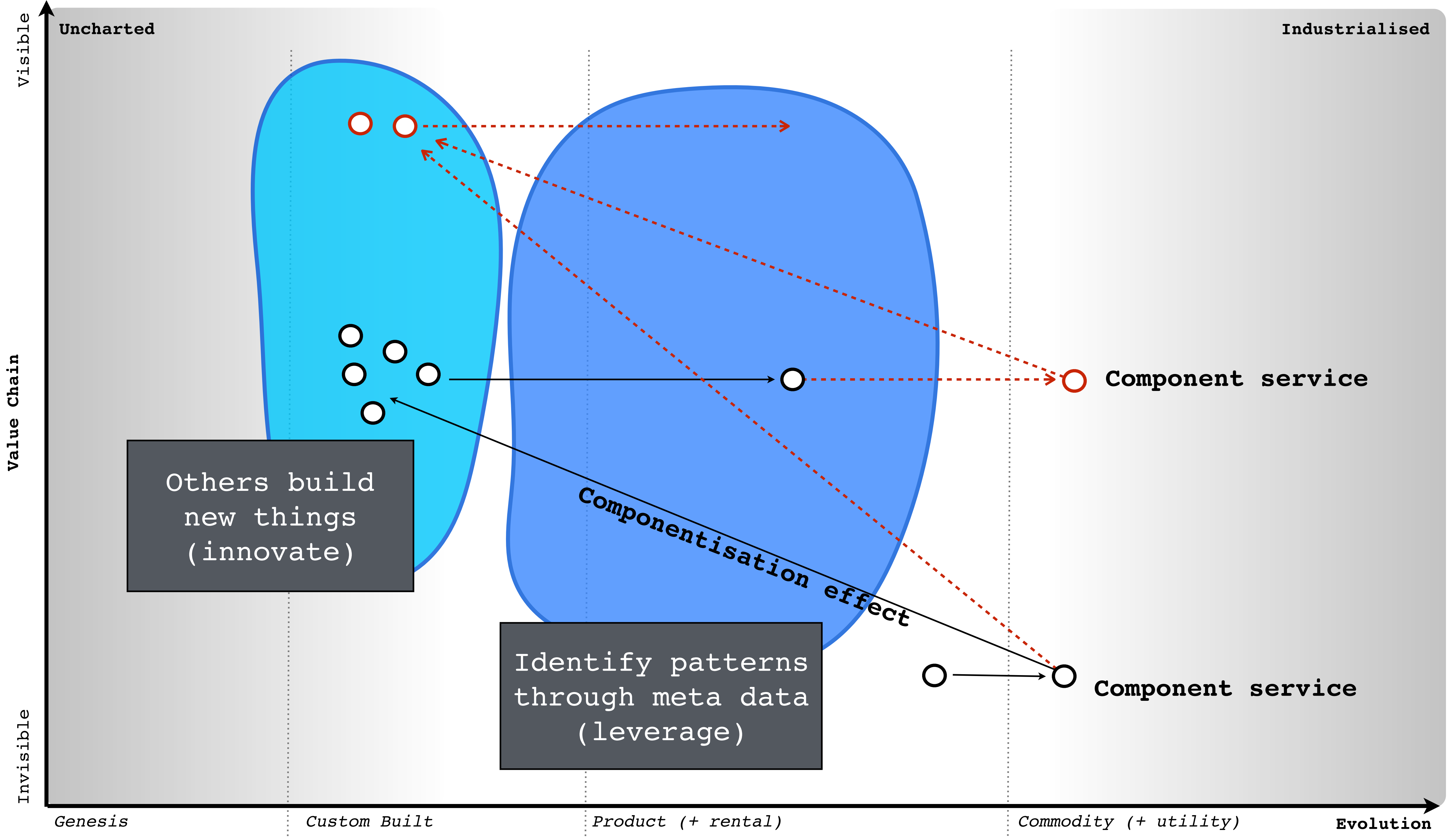

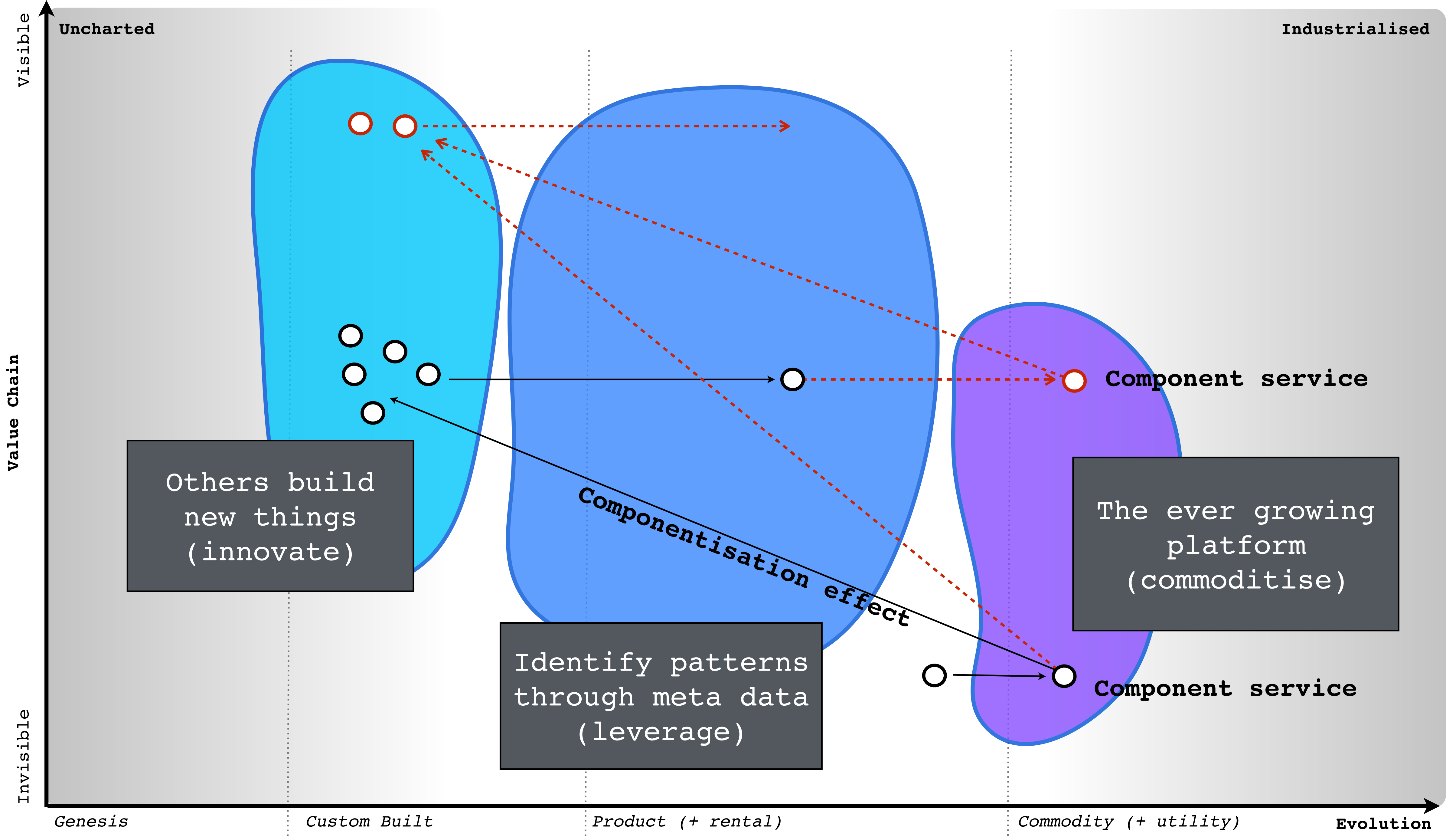

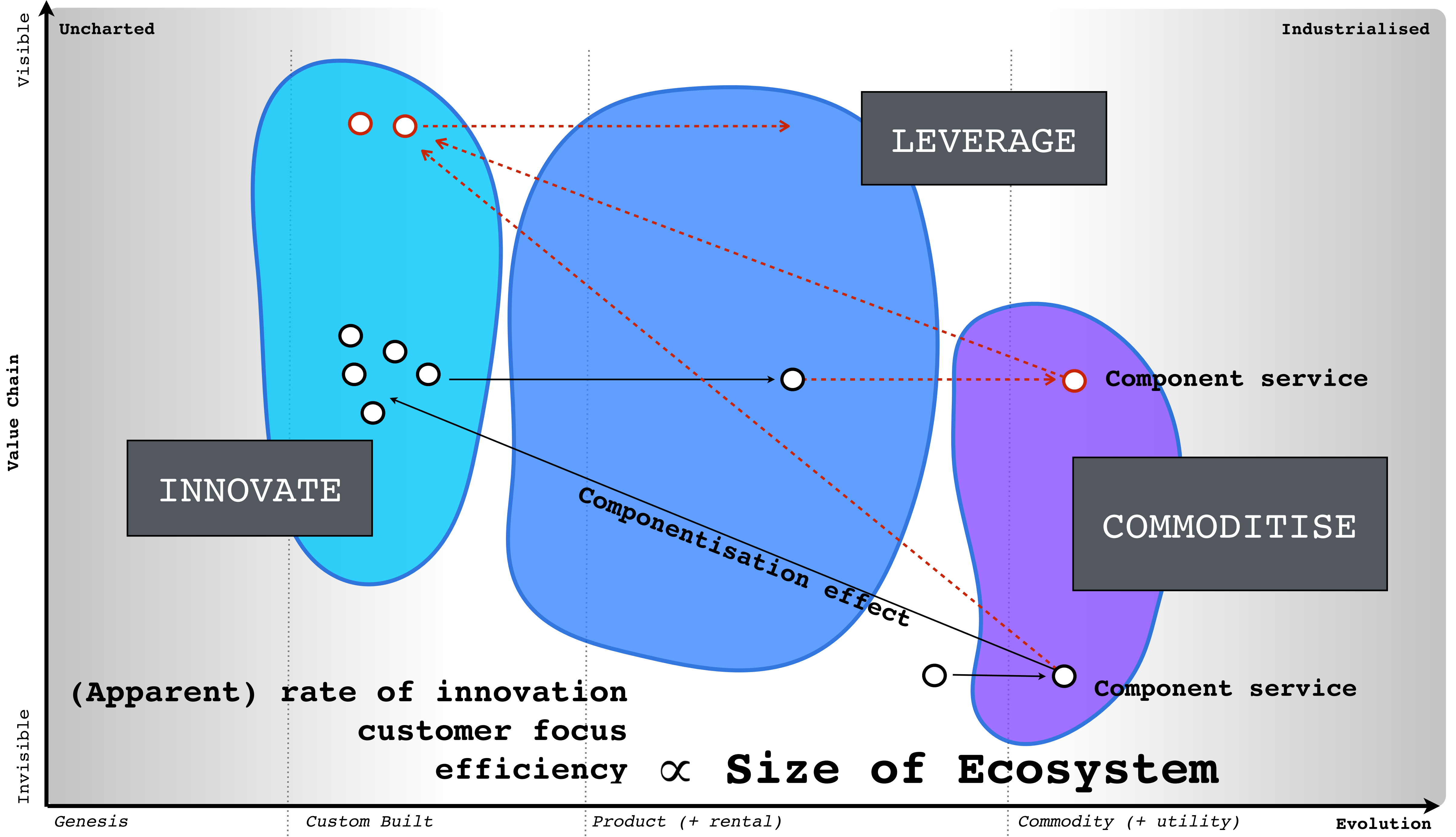

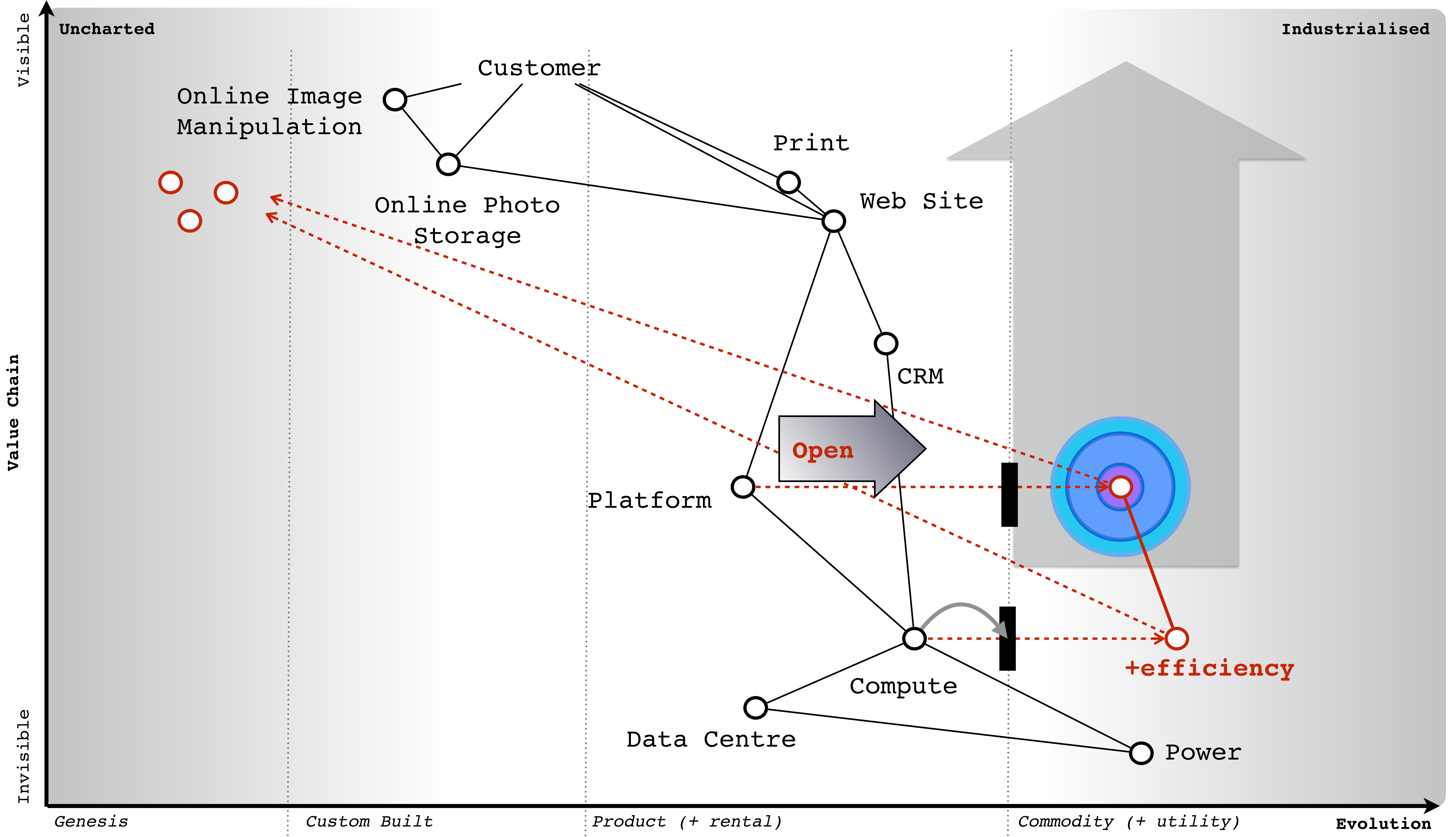

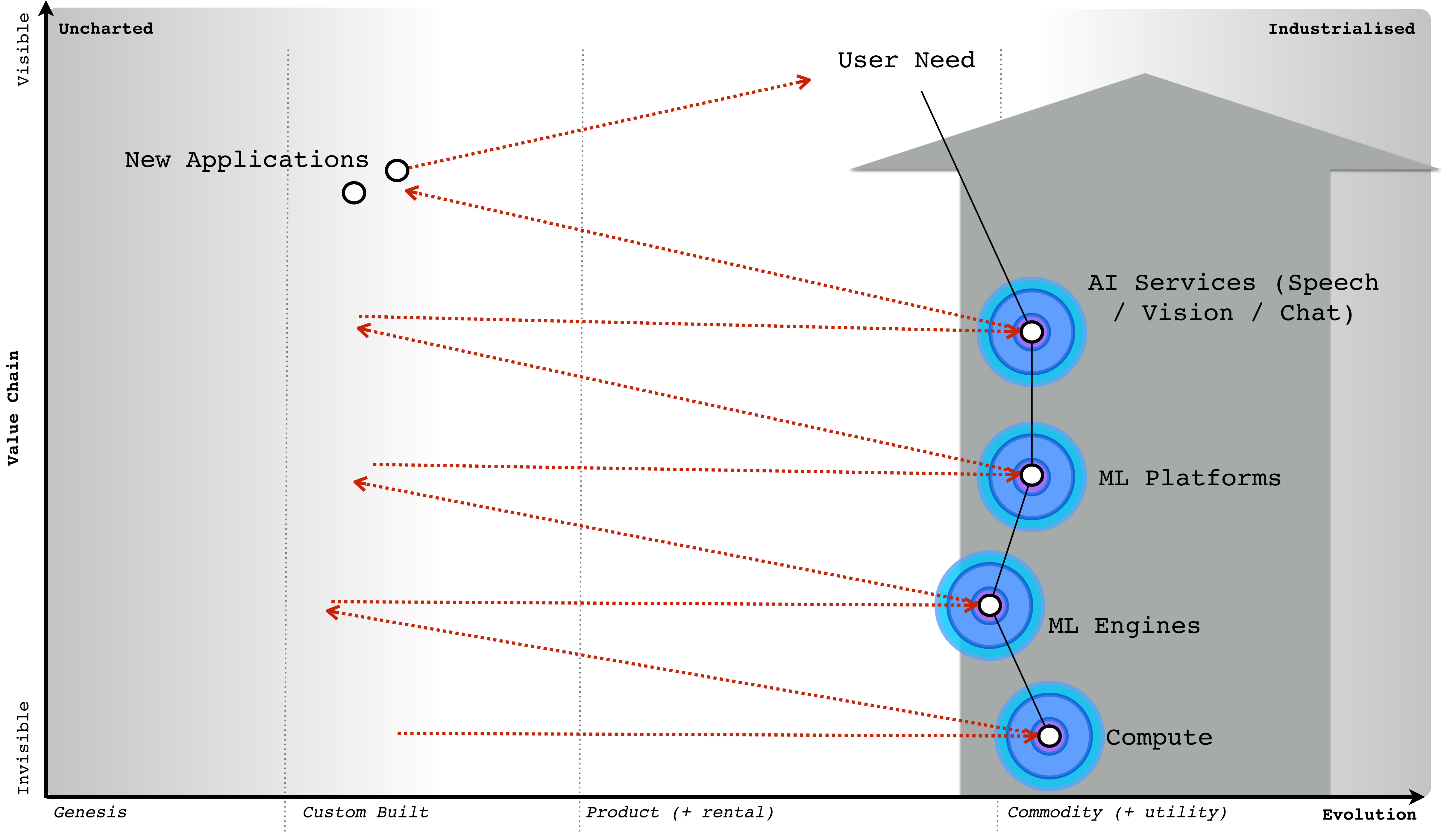

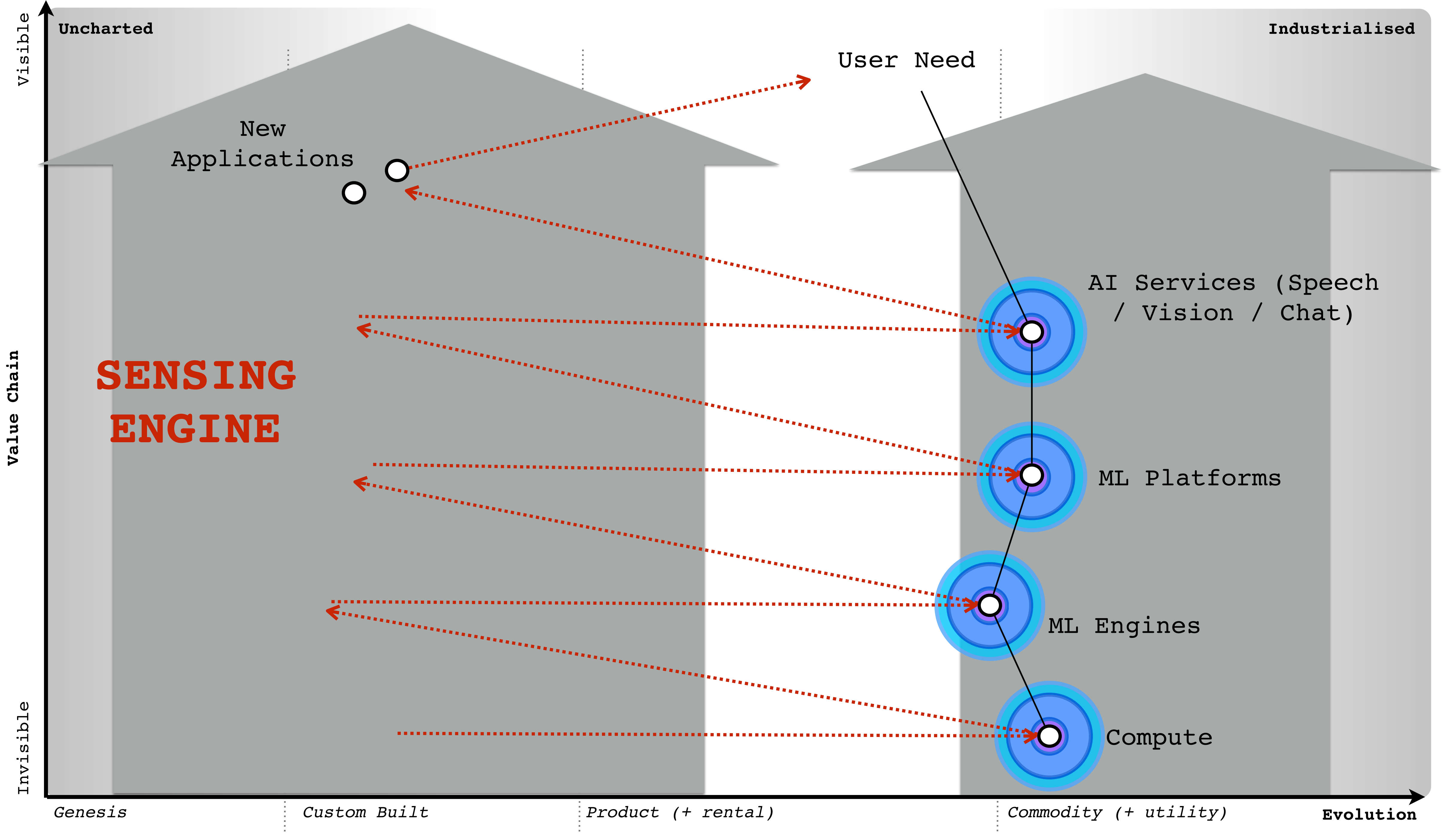

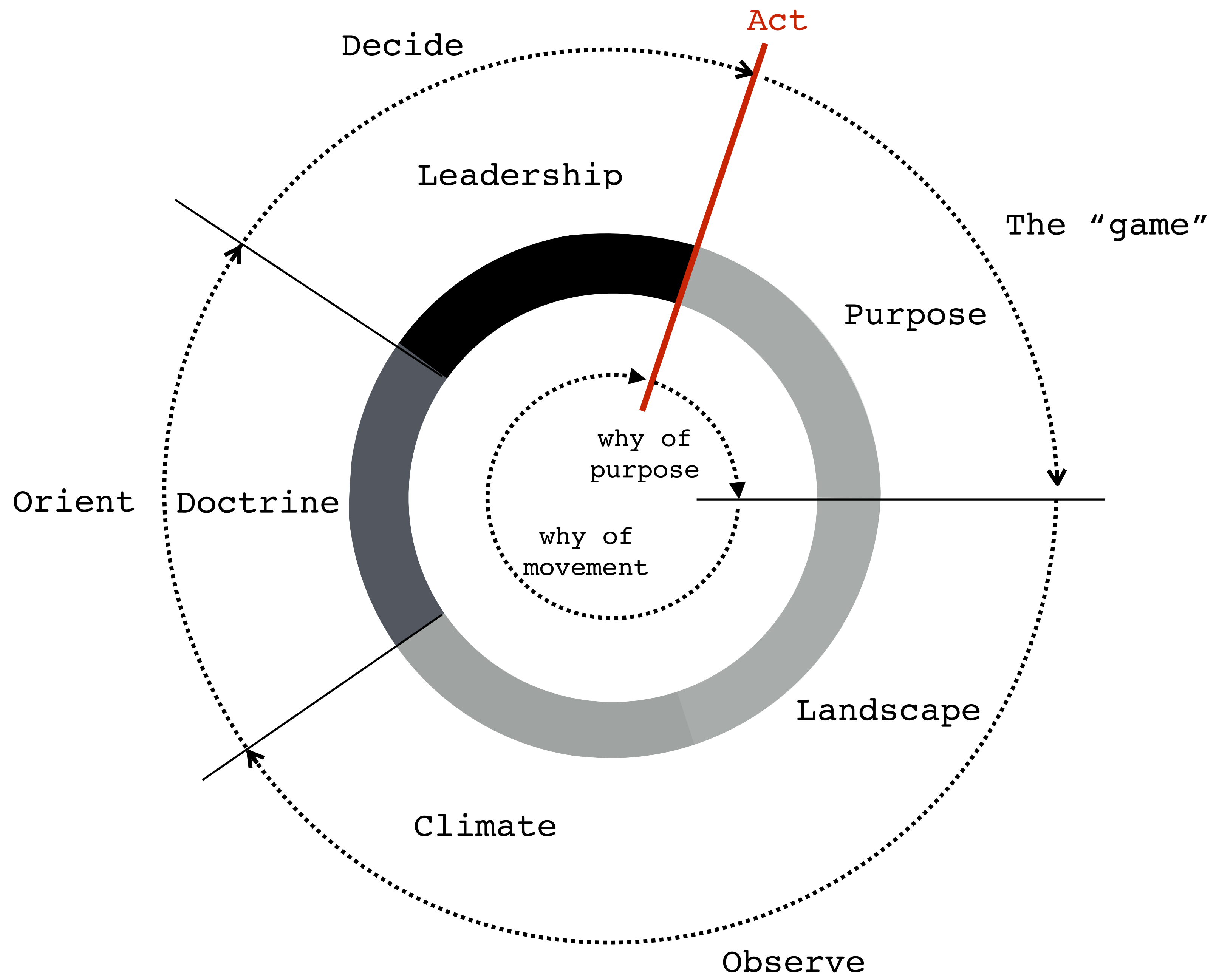



pre-shaved yaks

application development

environment

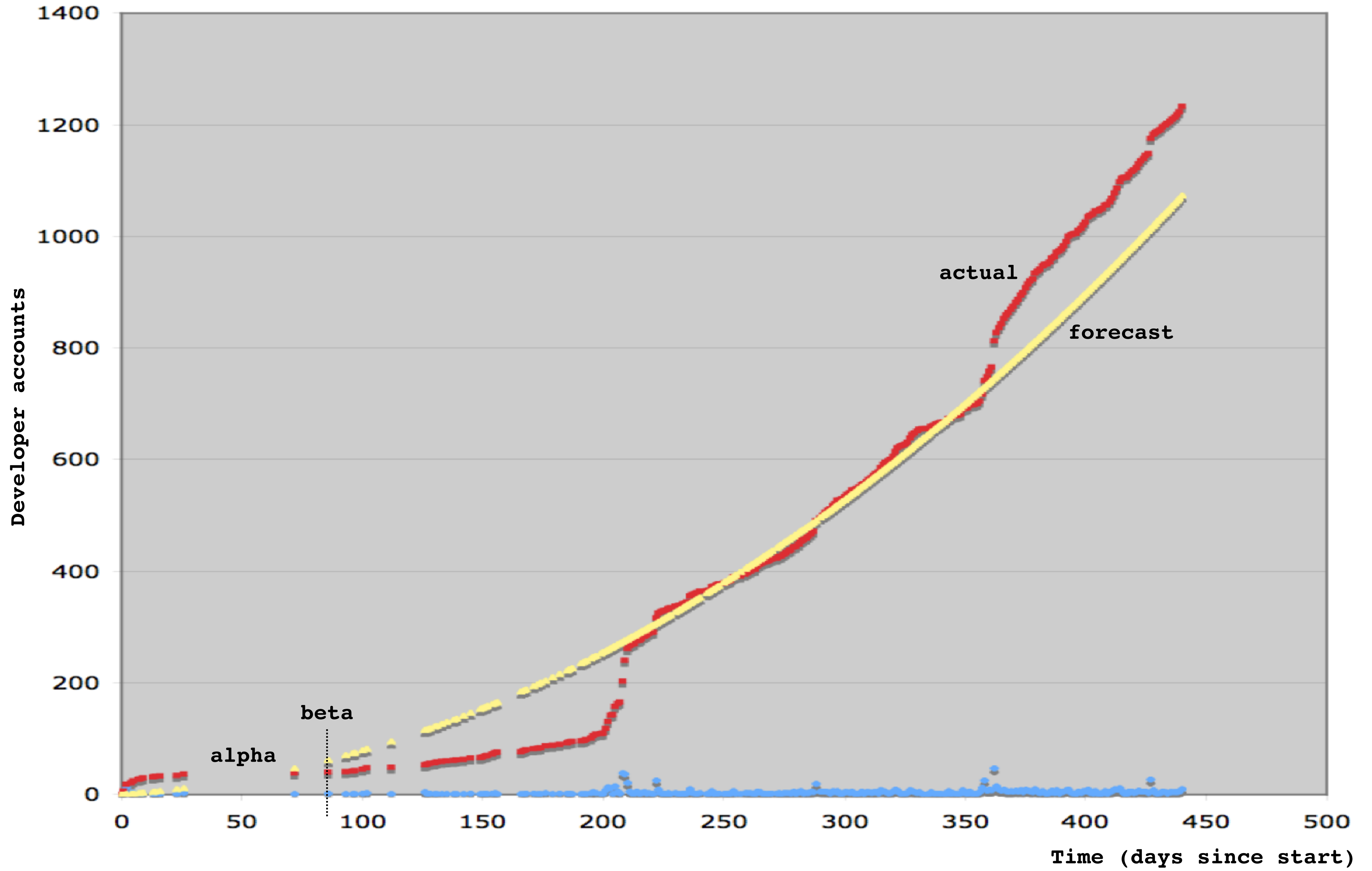

How Evolutionary Biologists Can Signify Leadership Potential

by Carl Senior, Robin Martin, Michael West, and Rowena M. Yeats

FROM THE NOVEMBER 2011 ISSUE



SAVE



SHARE



COMMENT



TEXT SIZE



PRINT



BUY COPIES

Evolutionary biologists have learned that people with greater “genetic fitness,” as manifested by a high degree of left-right body symmetry, are not just considered better looking but also tend to be healthier, more intelligent, and more dominant than others. They’re the classic alphas who rise to the top of rigidly hierarchical organizations such as the military.

But [our research](#) shows that people with subtle asymmetries—for example, imbalances in ear or finger length—are often better “transformational” leaders, able to inspire followers to put self-interest aside for the good of the group. Furthermore, teams they lead outperform teams whose leaders have more-symmetrical bodies.

How many times have you ever learned from a past ...

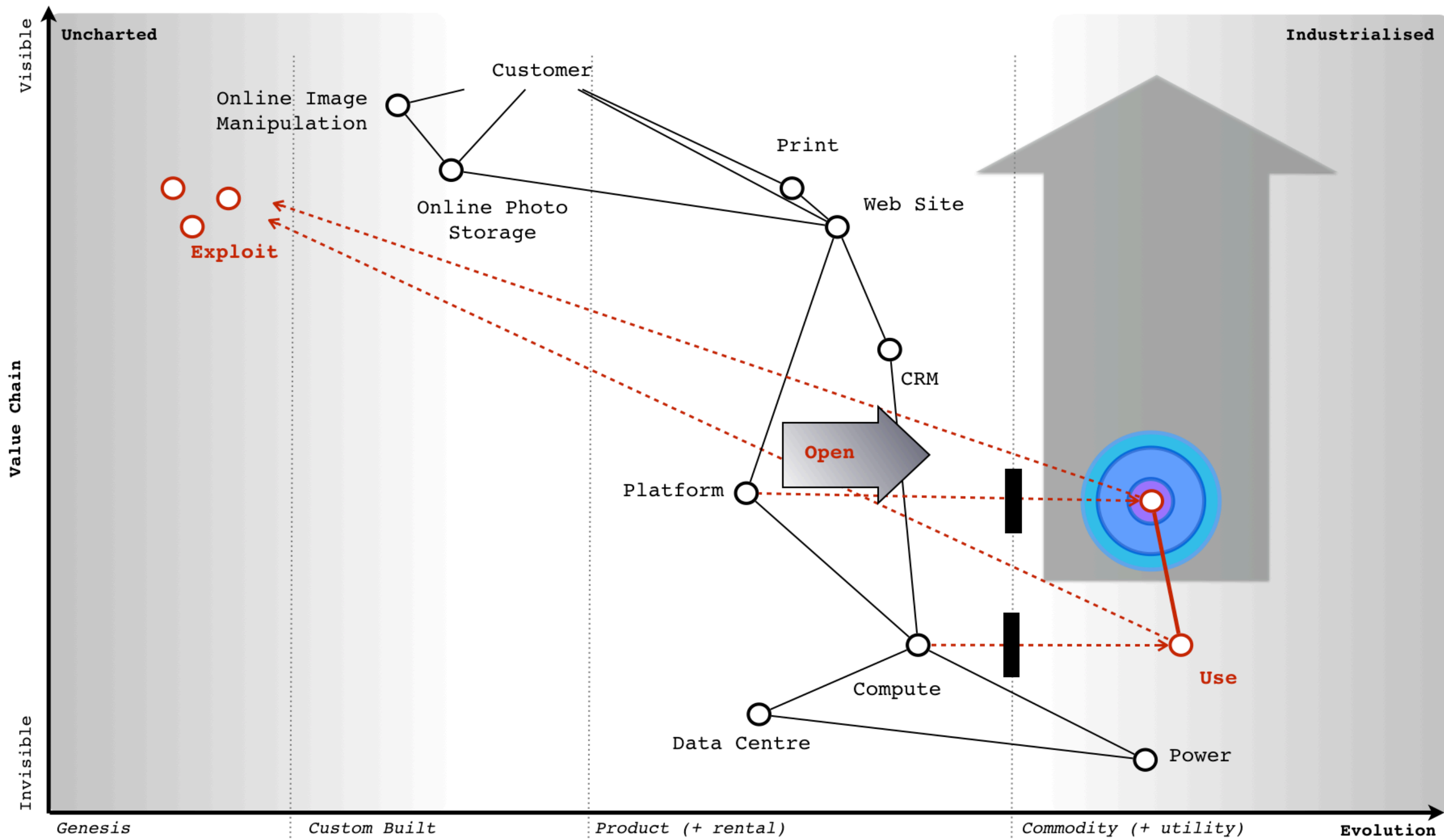

MAP

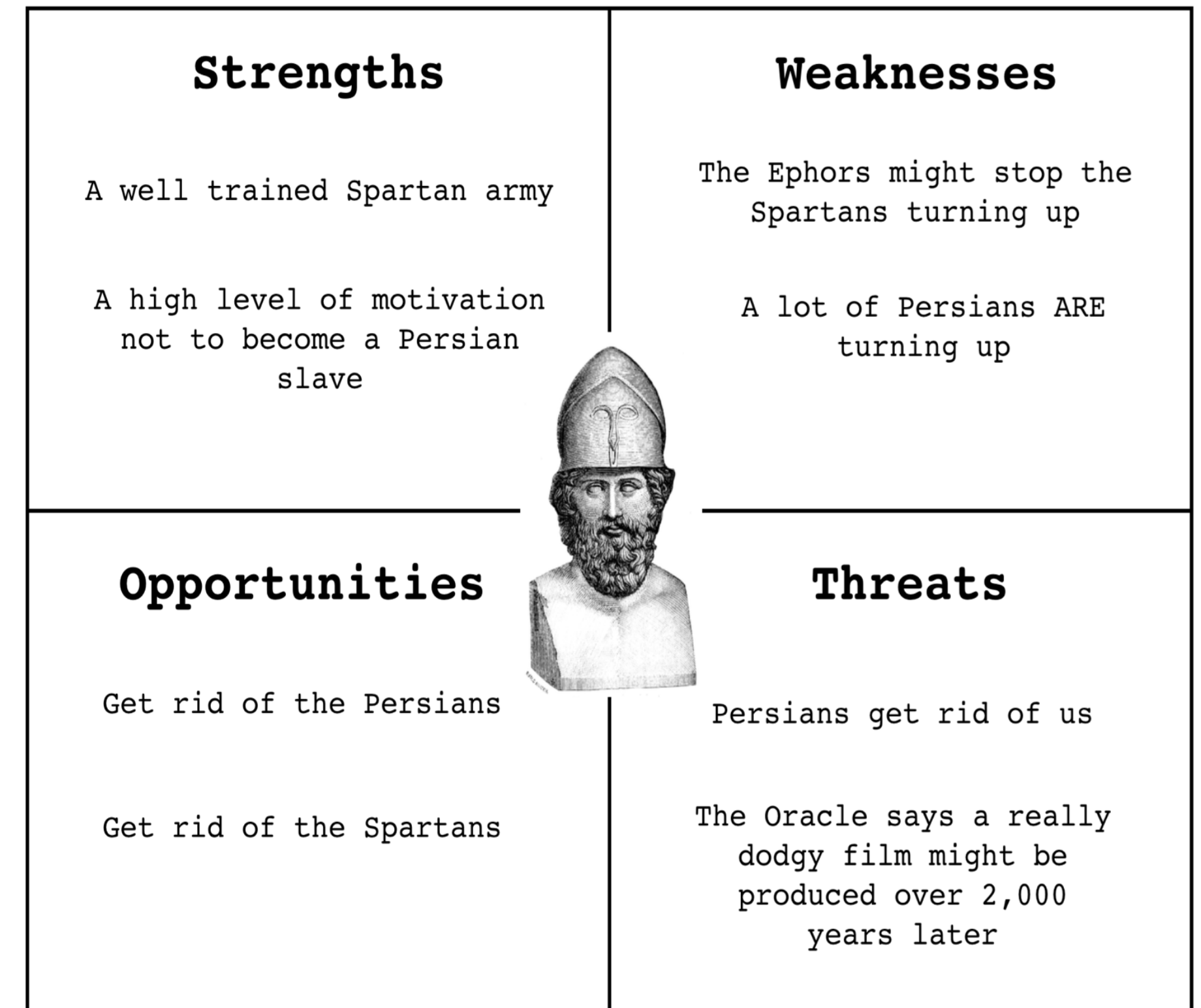

SWOT



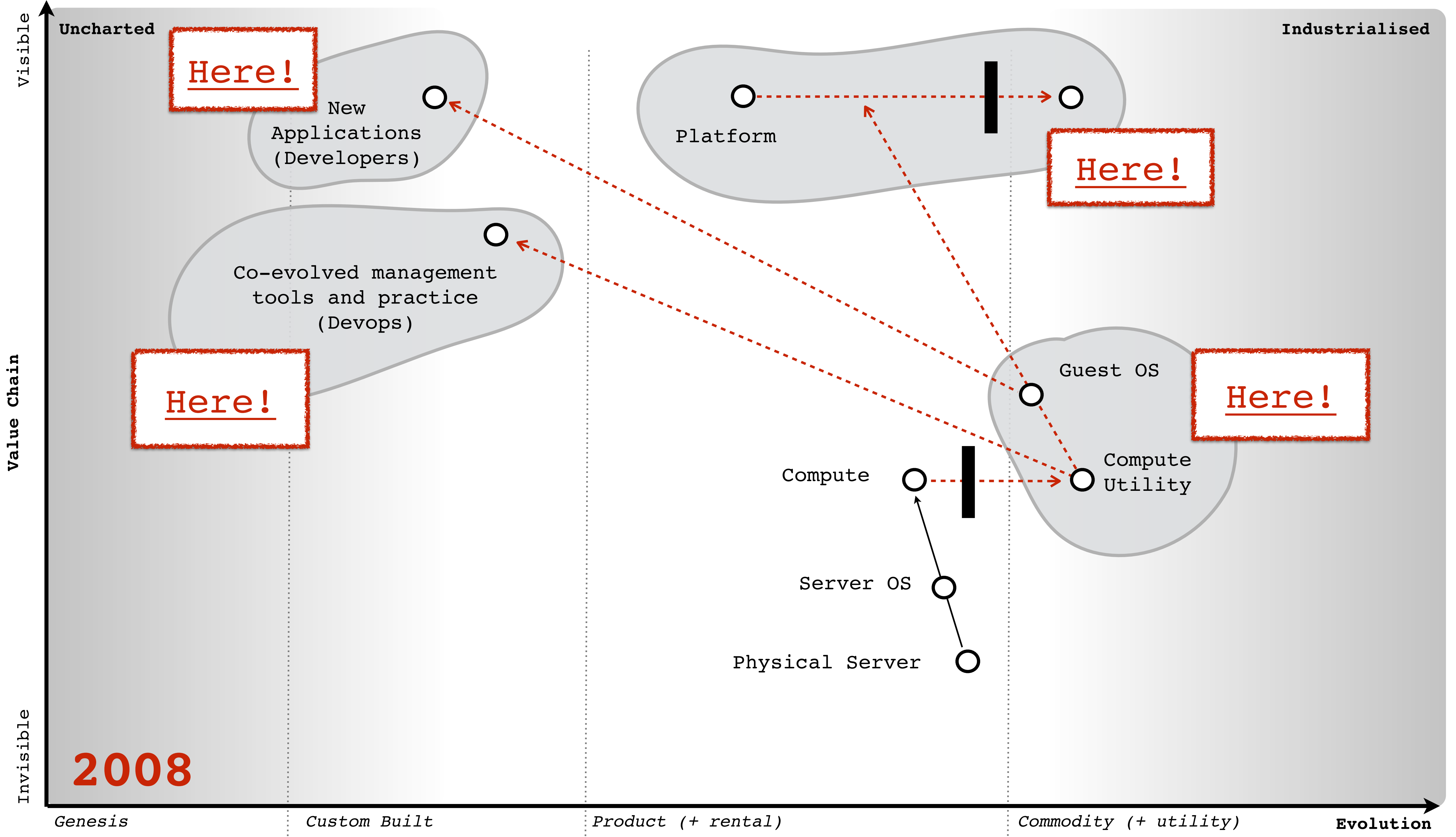

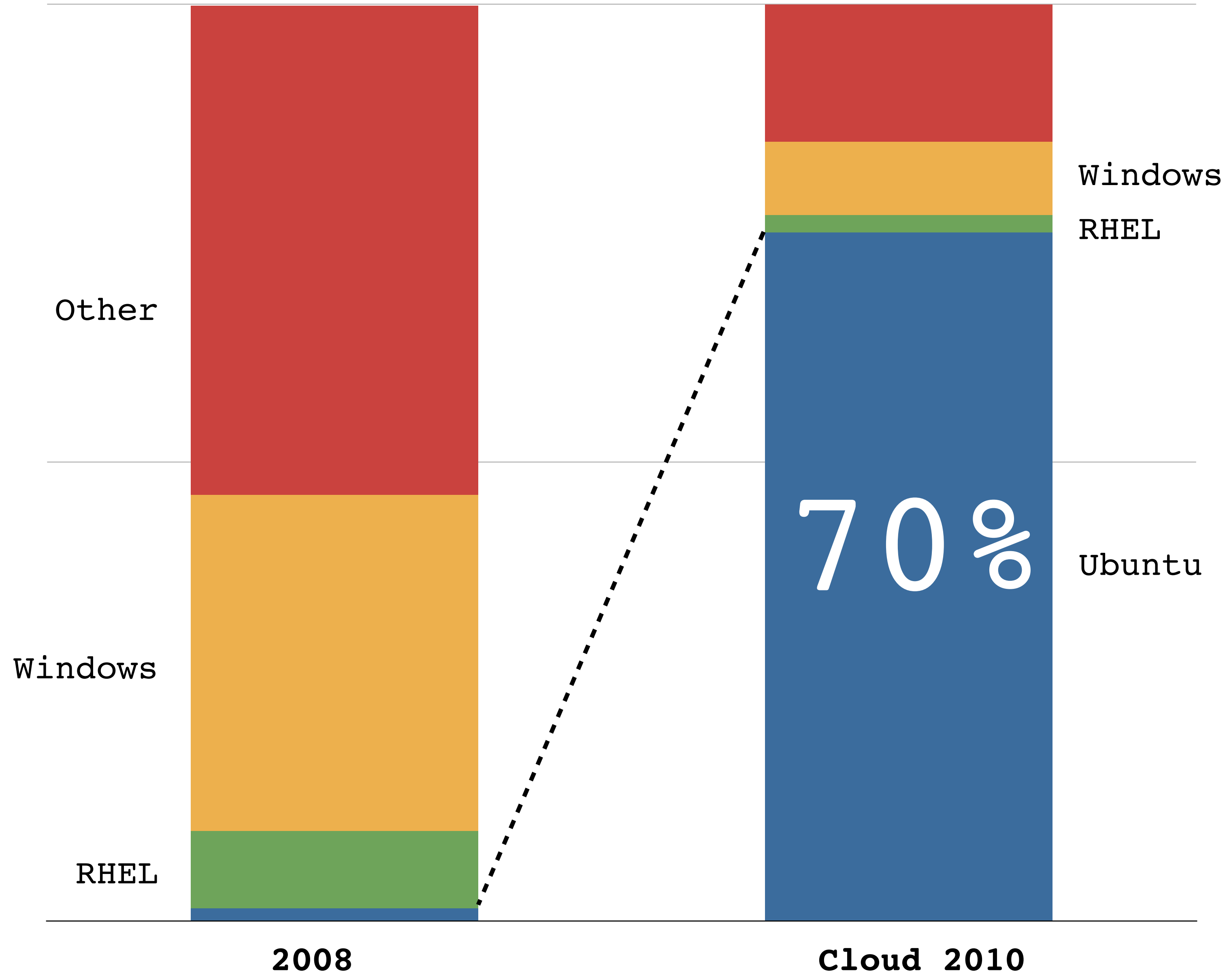

pba

the network for the post-bureaucratic age

“Better for Less”

How to make Government IT deliver savings.

Liam Maxwell

with contributions from

Jerry Fishenden

William Heath

Jonathan Sowler

Peter Rowlin

Mark Thompson

Simon Wardley.



Liam Maxwell @liamax

Aug 26

Replying to @adriano @swardley

In 2014 using a Wardley Map we plotted how to remove one of the biggest blockers to tech reform. The service we created in 2015 has saved ..



Liam Maxwell @liamax

Aug 26

Replying to @adriano @swardley

£425m and will likely save north of £1.5bn in its lifetime. At MapCamp I'll show how we spotted it and why





Tower Lifeboat Station
2nd January 2002 to
7th May 2018

CALL OUTS SINCE 2 JAN 2002

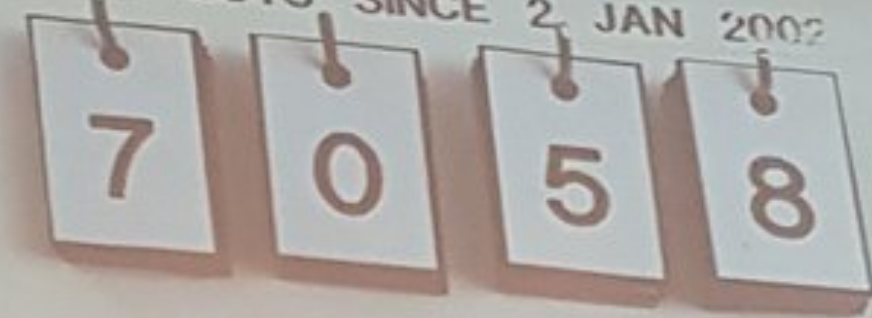

TOTAL LIVES SAVED



CALL OUTS THIS YEAR



LIVES SAVED THIS YEAR

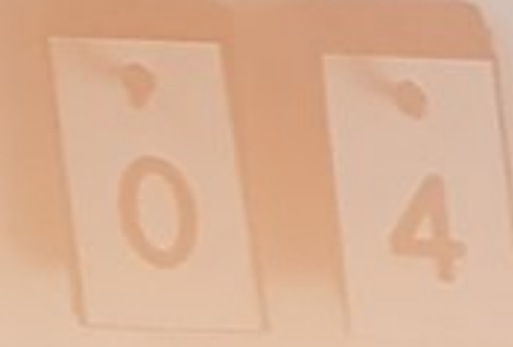

MAP CAMP

October 2018 London



Strategy

Maps

Communication

Patterns

Anticipation

Organisation

Leadership

SERVERLESS

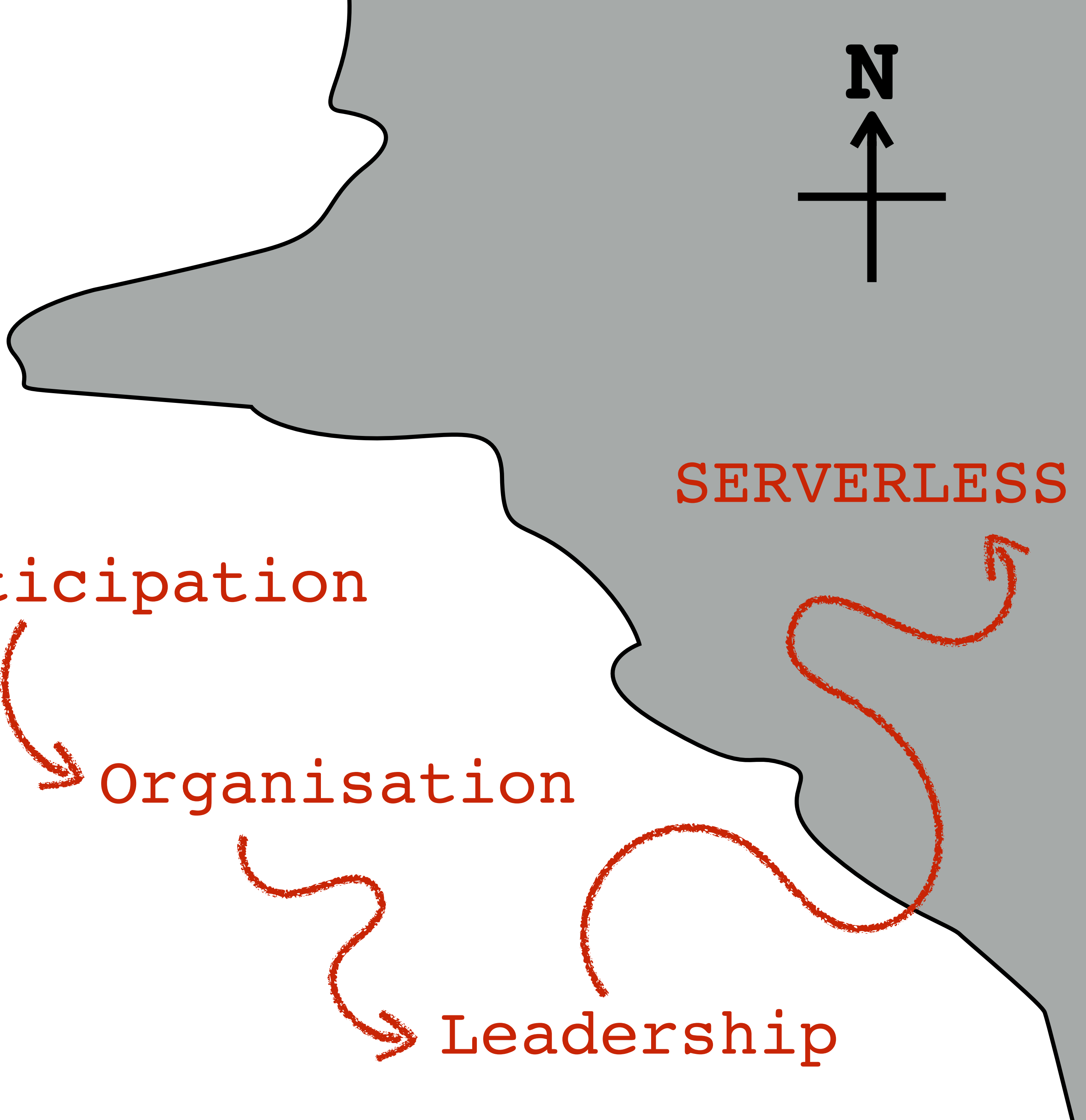
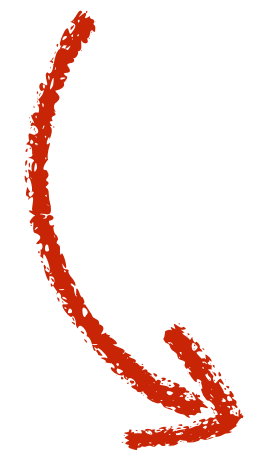
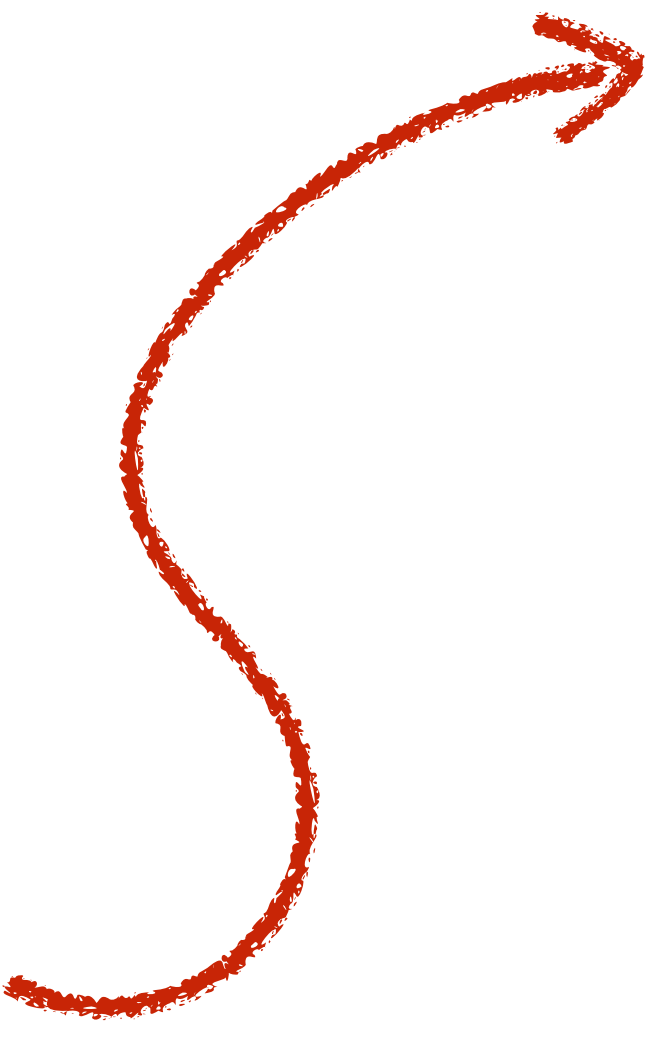
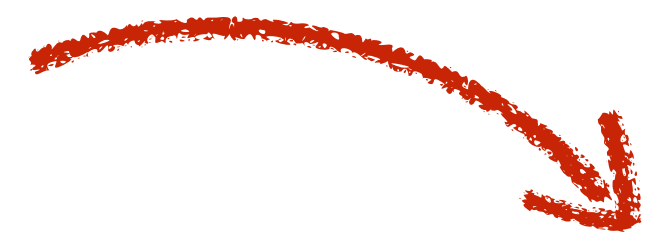
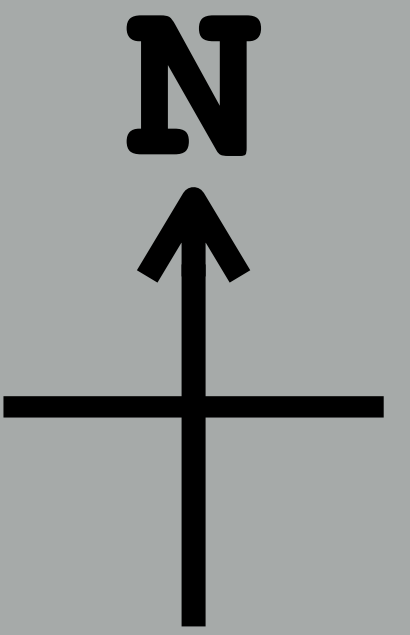

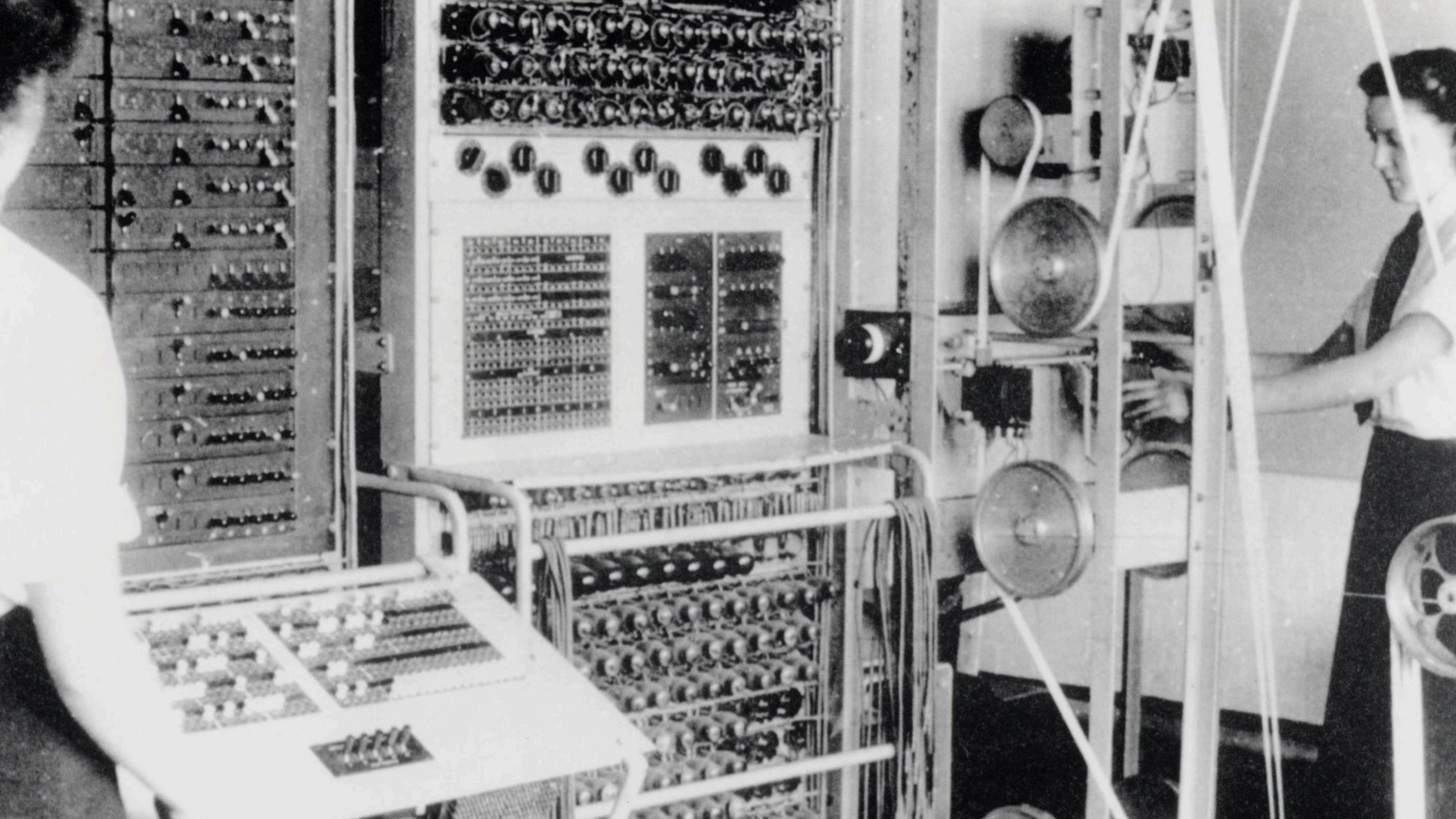

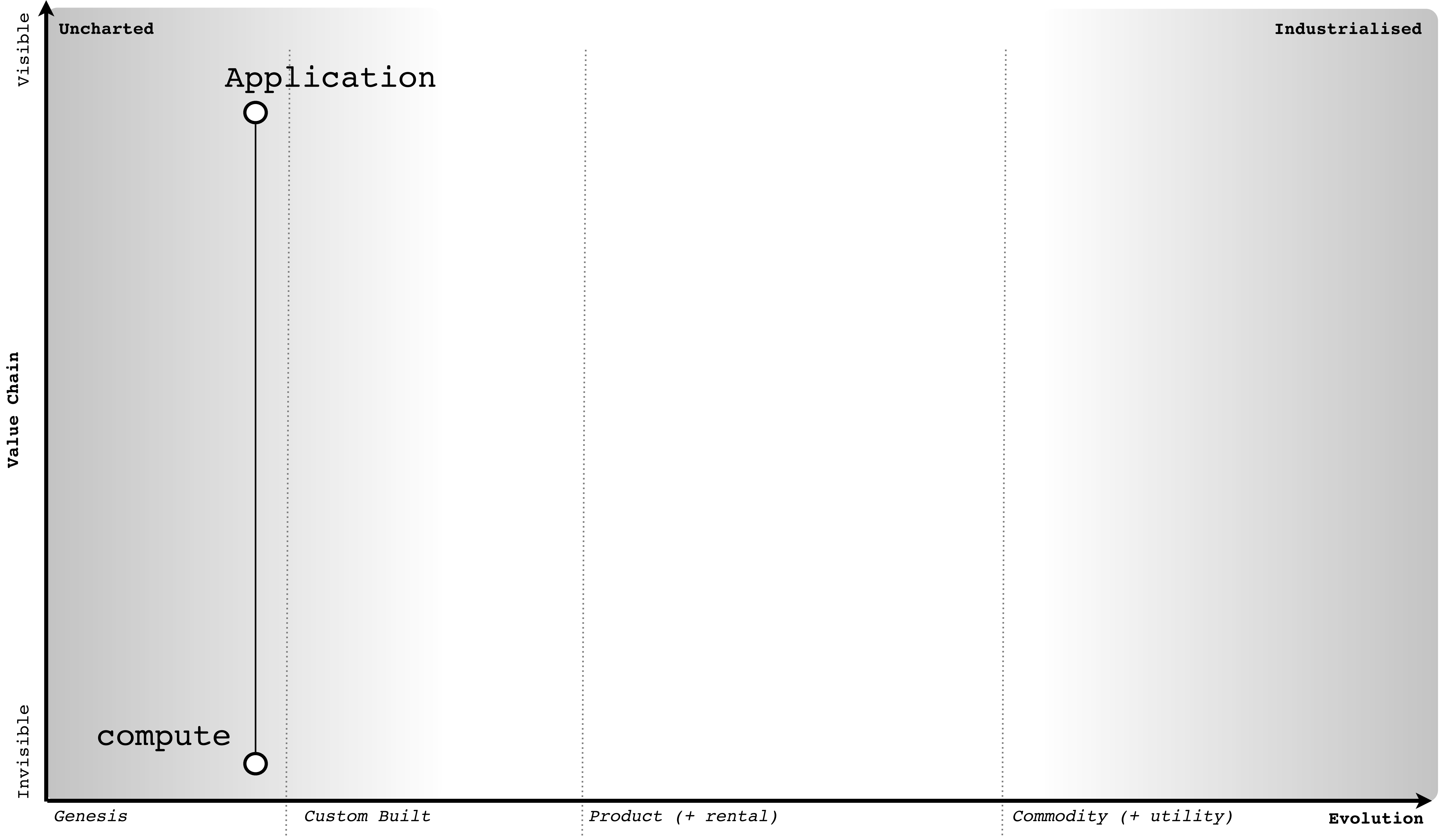

Visible

Uncharted

Industrialised

Application

Value Chain

Invisible

compute

Genesis

Custom Built

Product (+ rental)

Commodity (+ utility)

Evolution

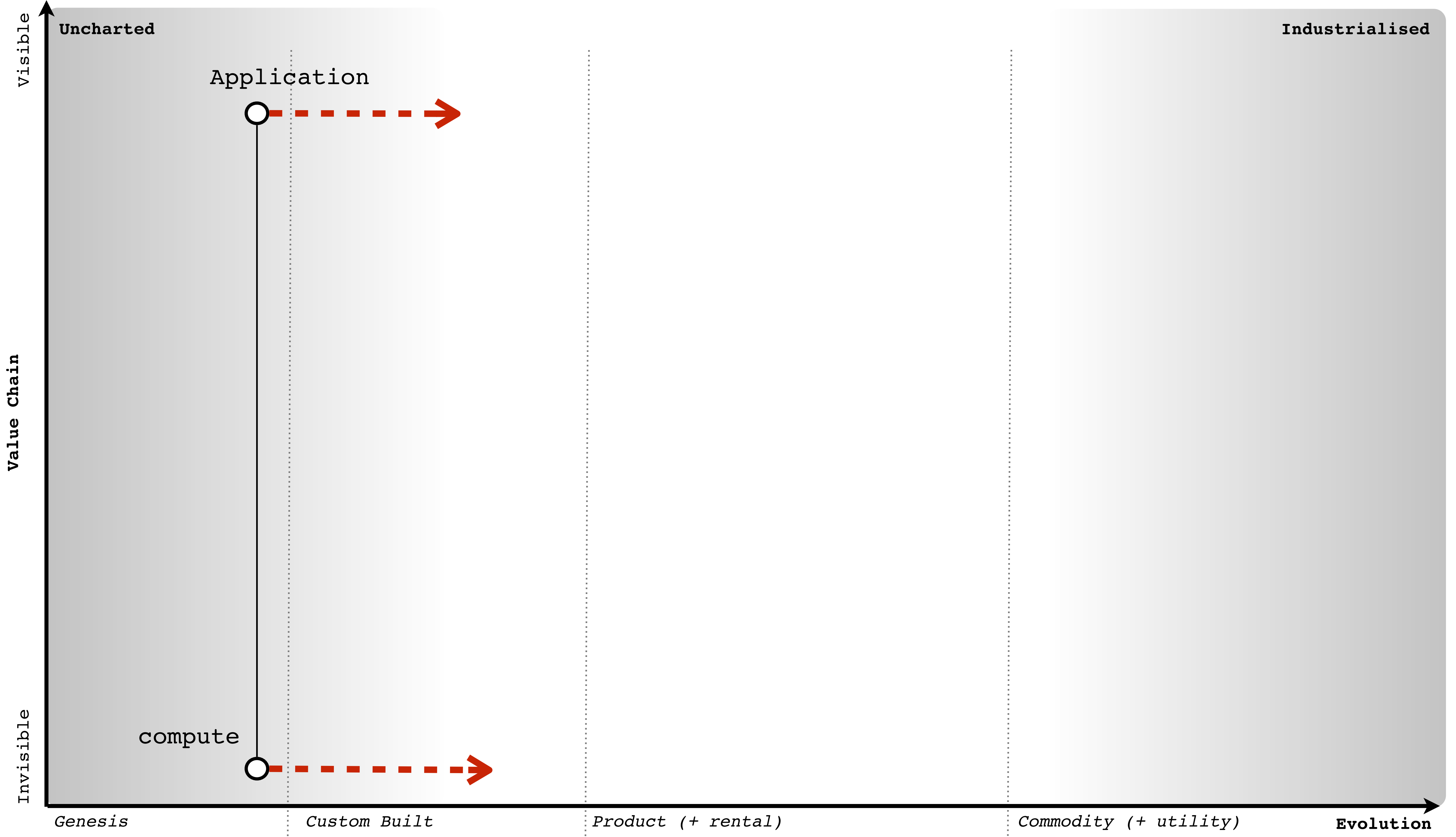

Visible

Uncharted

Industrialised

Application

Value Chain

Invisible

compute

Genesis

Custom Built

Product (+ rental)

Commodity (+ utility)

Evolution

LEO



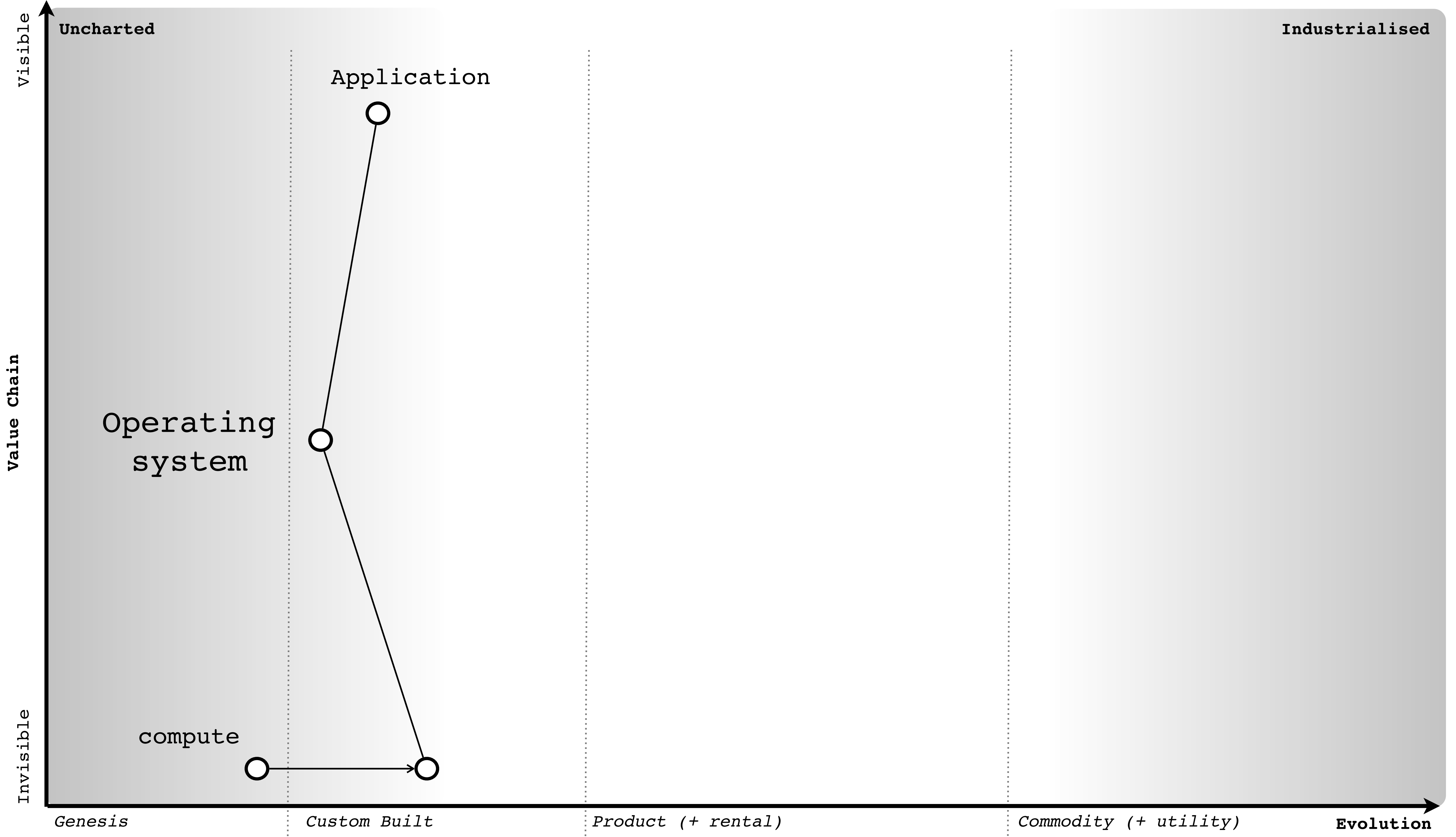

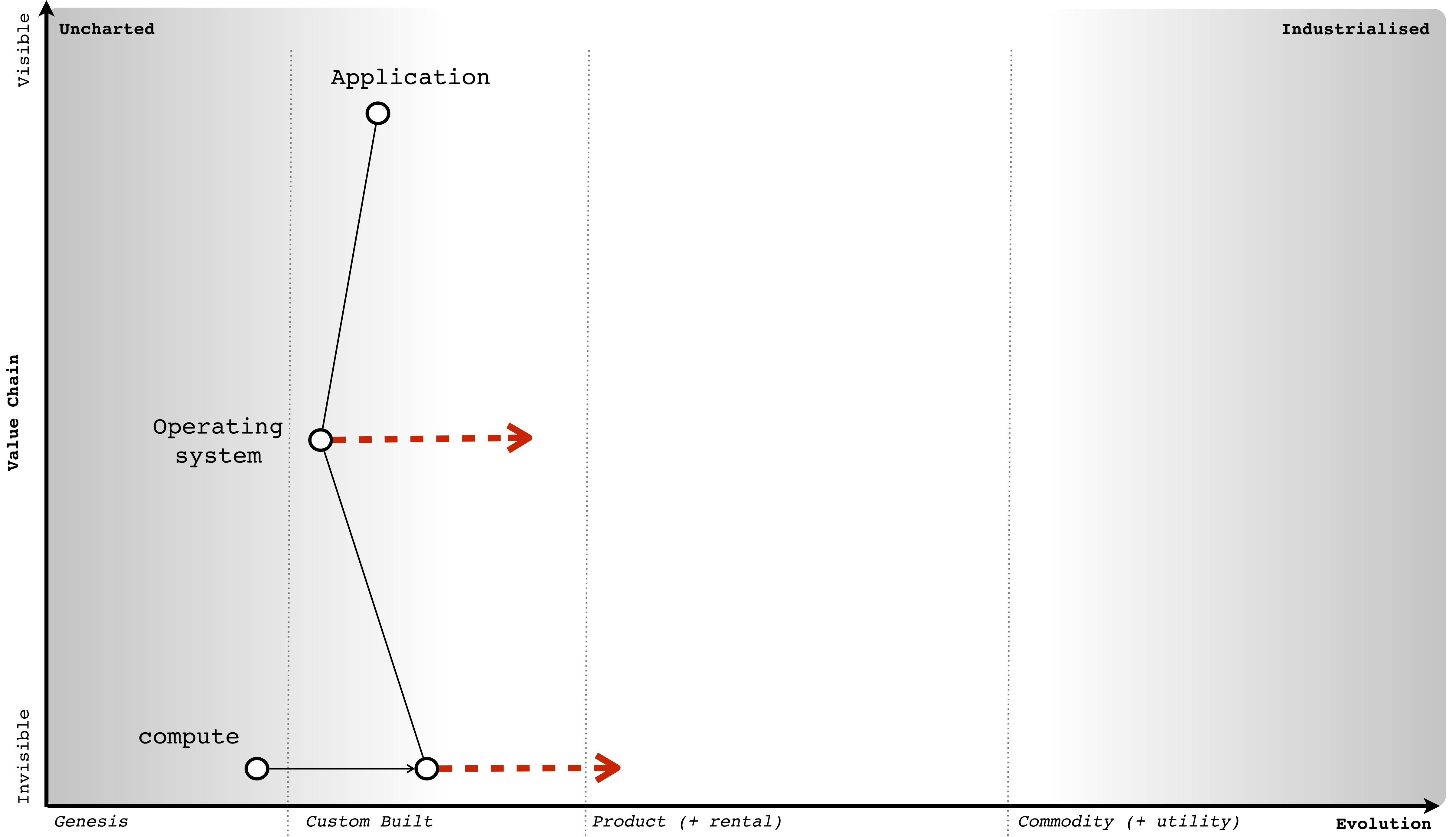



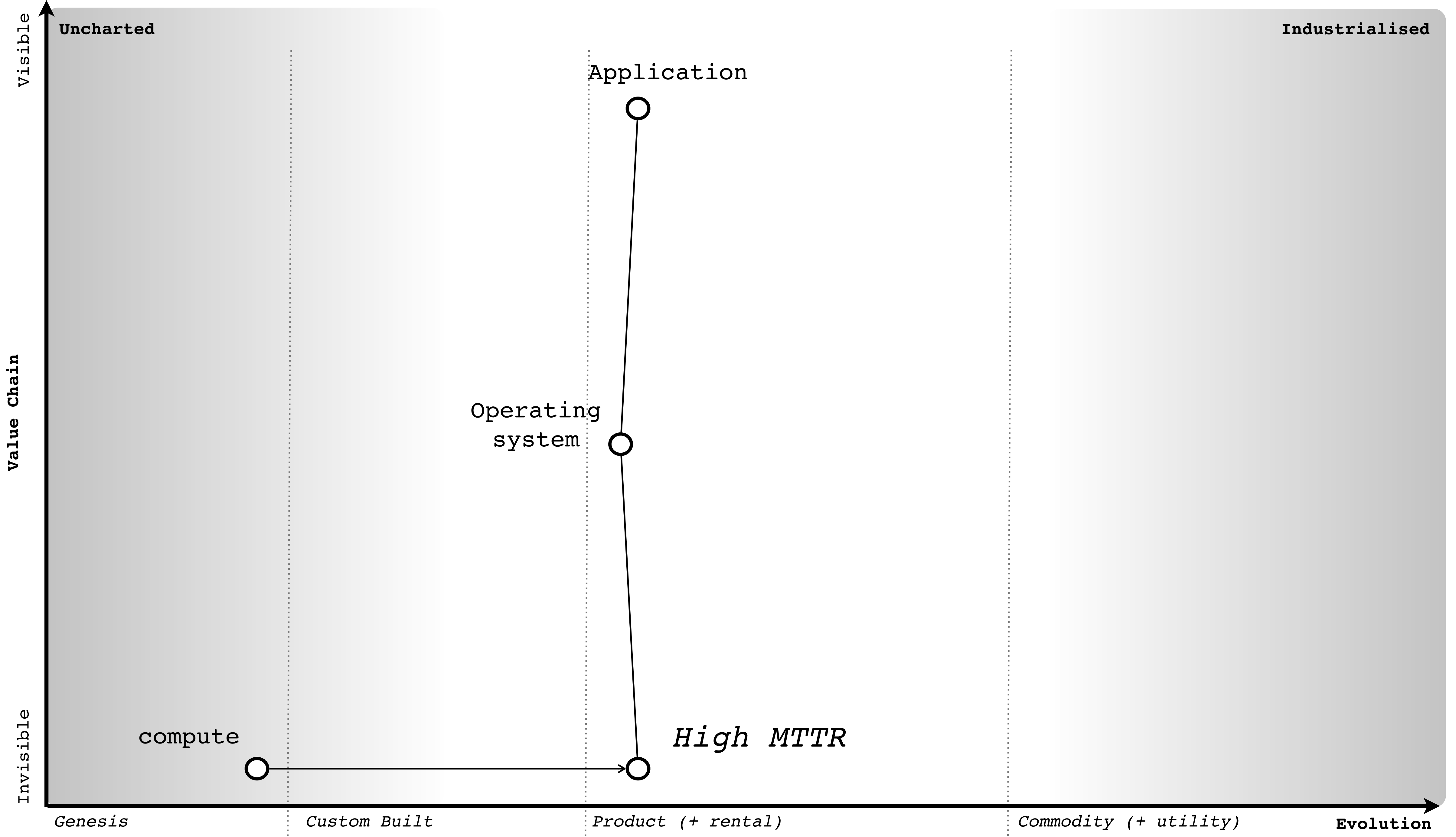

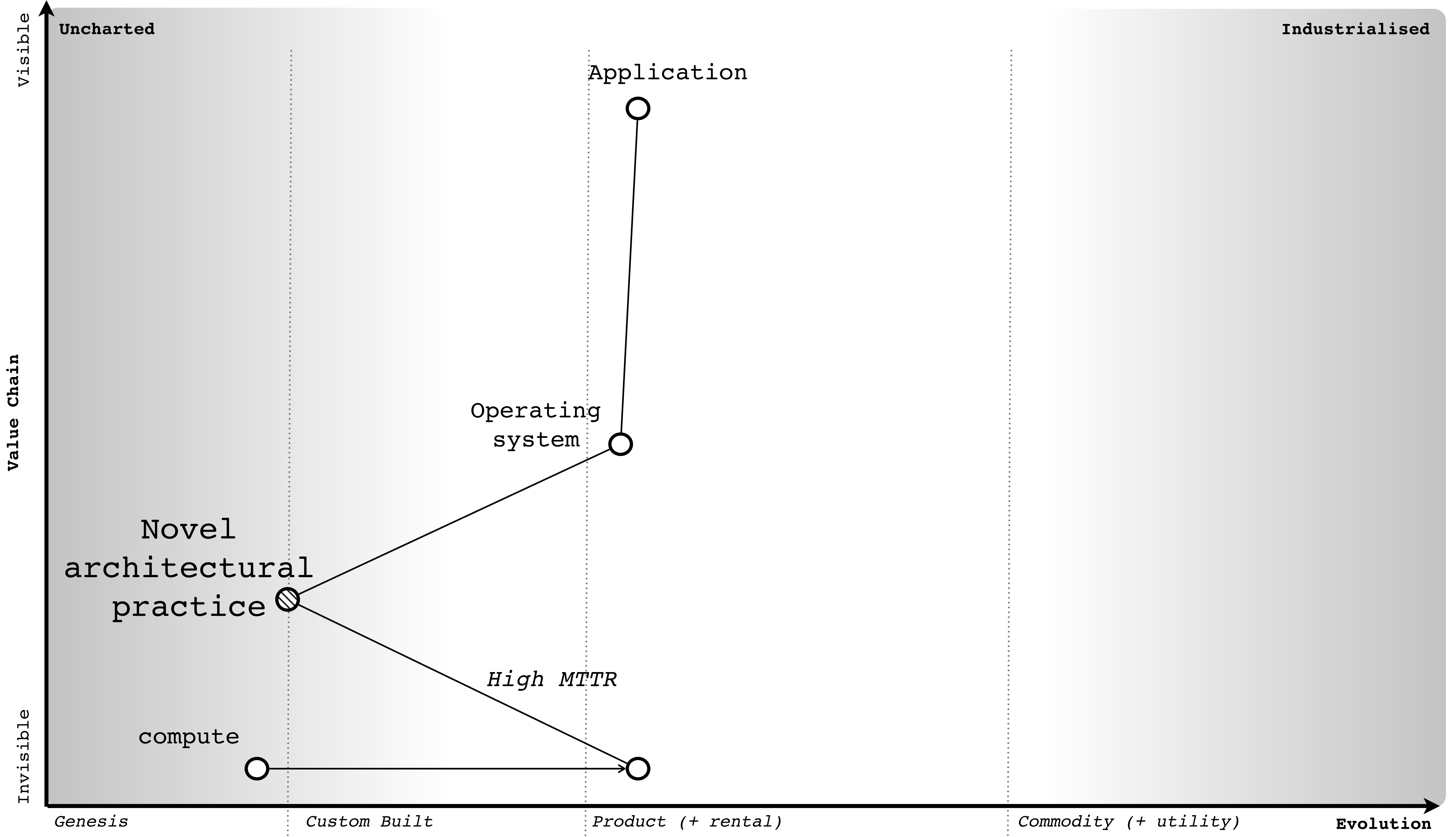

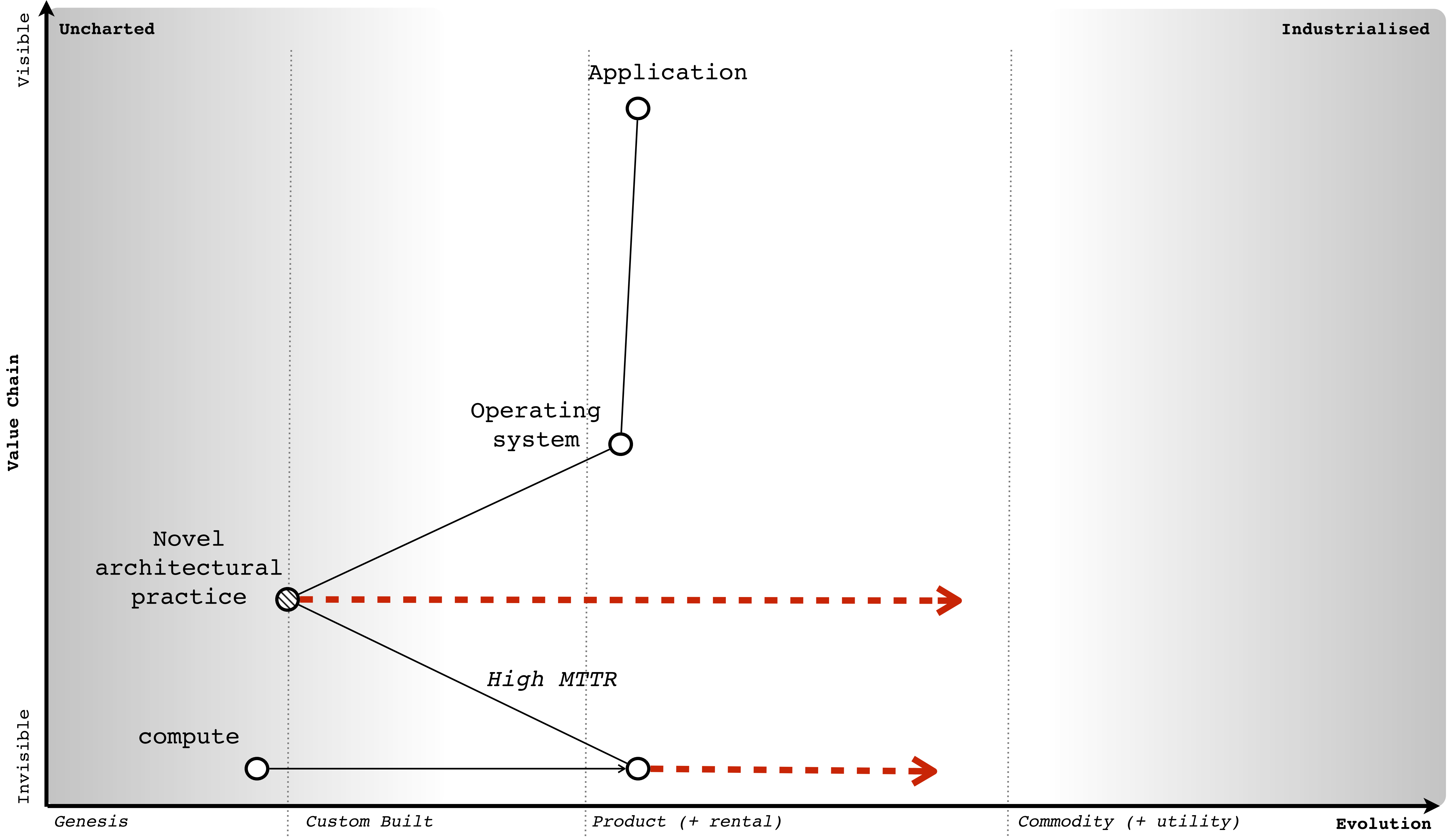

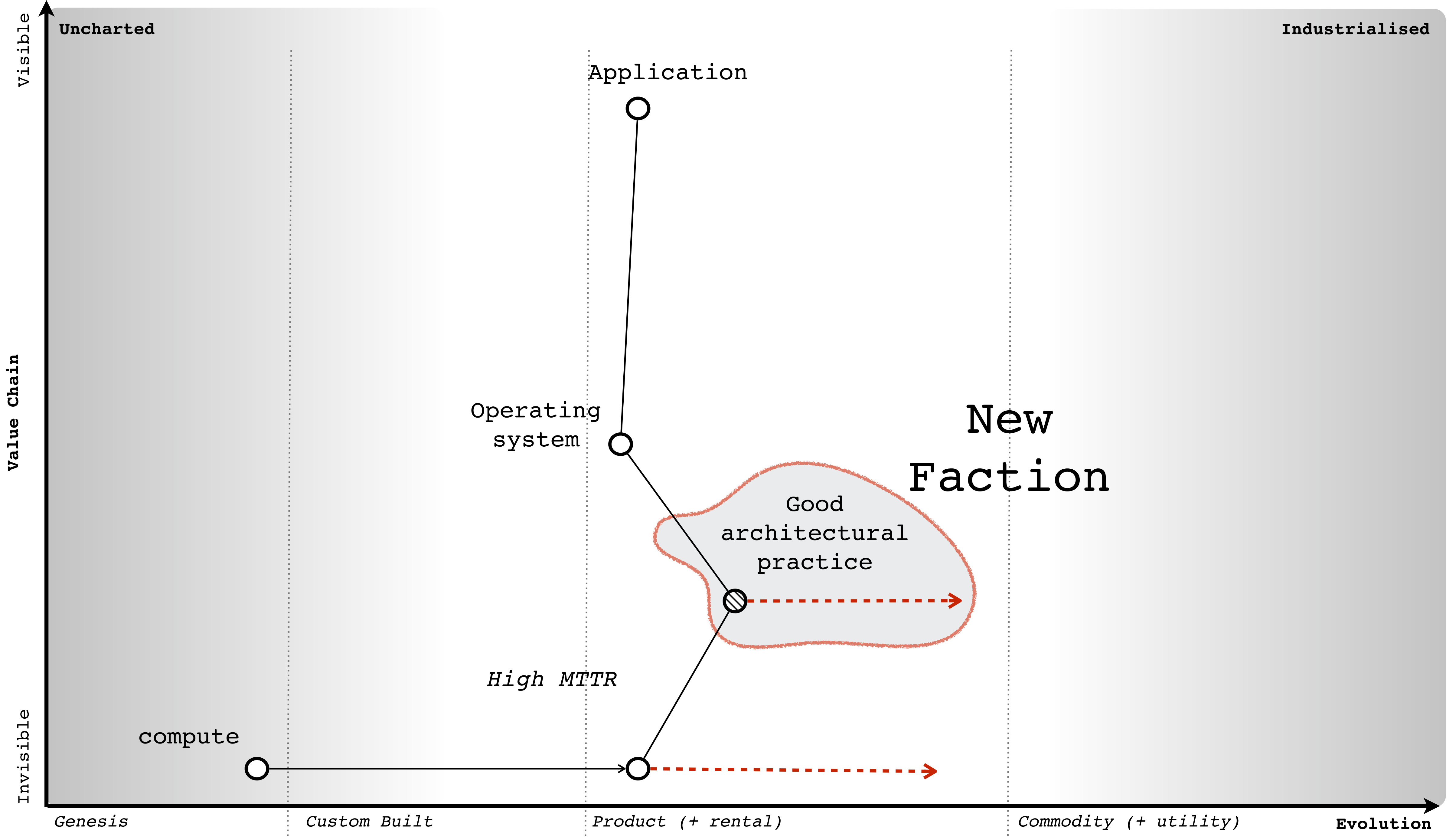

Visible

Uncharted

Industrialised

Value Chain

Application

Operating system

New Faction

Good architectural practice

High MTTR

compute

Invisible

Genesis

Custom Built

Product (+ rental)

Commodity (+ utility)

Evolution



LOLs, no
capacity
planning!



Java™

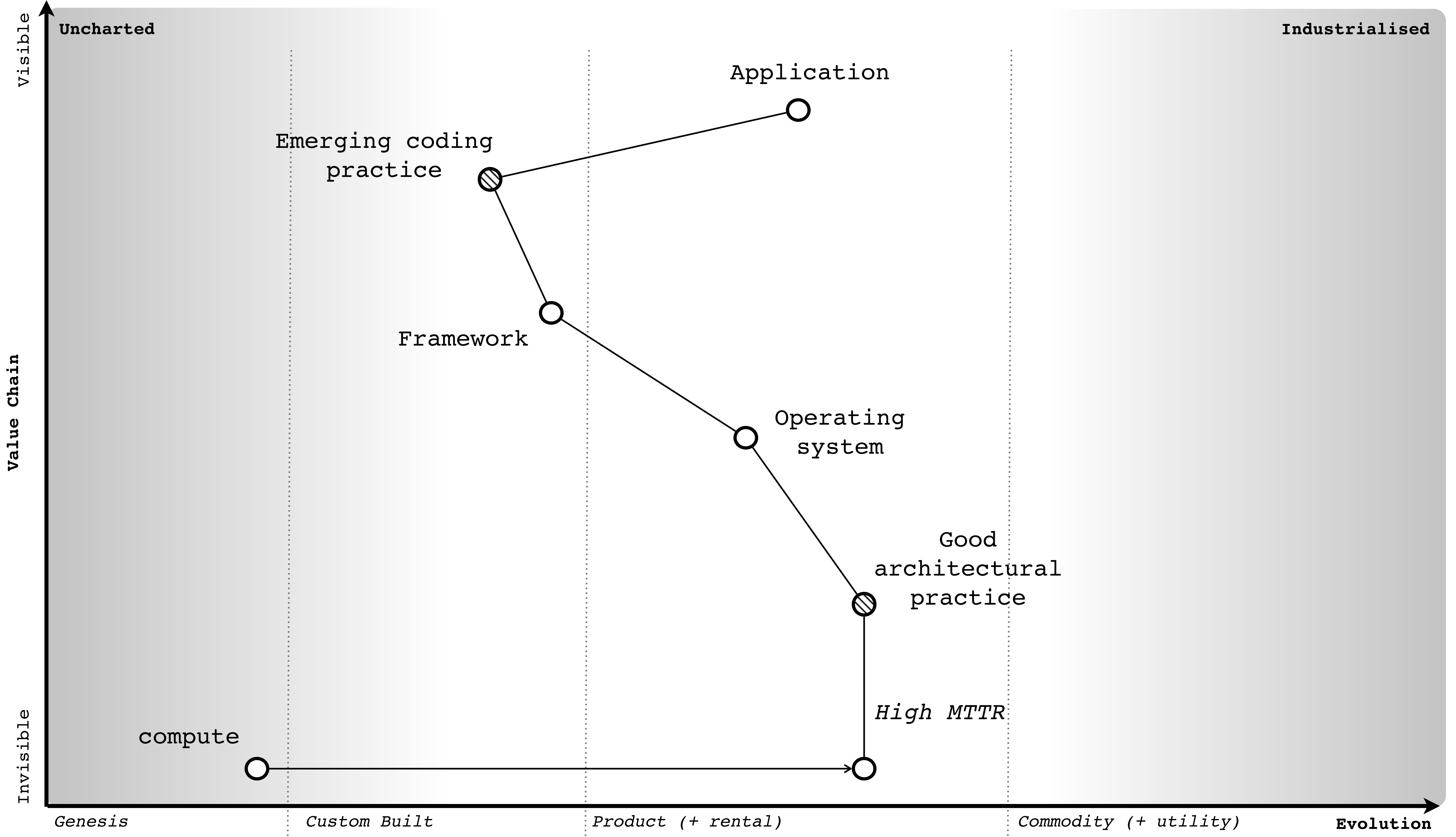

Uncharted

Industrialised

Visible

Value Chain

Invisible

Genesis

Custom Built

Product (+ rental)

Commodity (+ utility)

Evolution

Application

Emerging coding practice

Framework

Operating system

Good architectural practice

High MTTR

compute

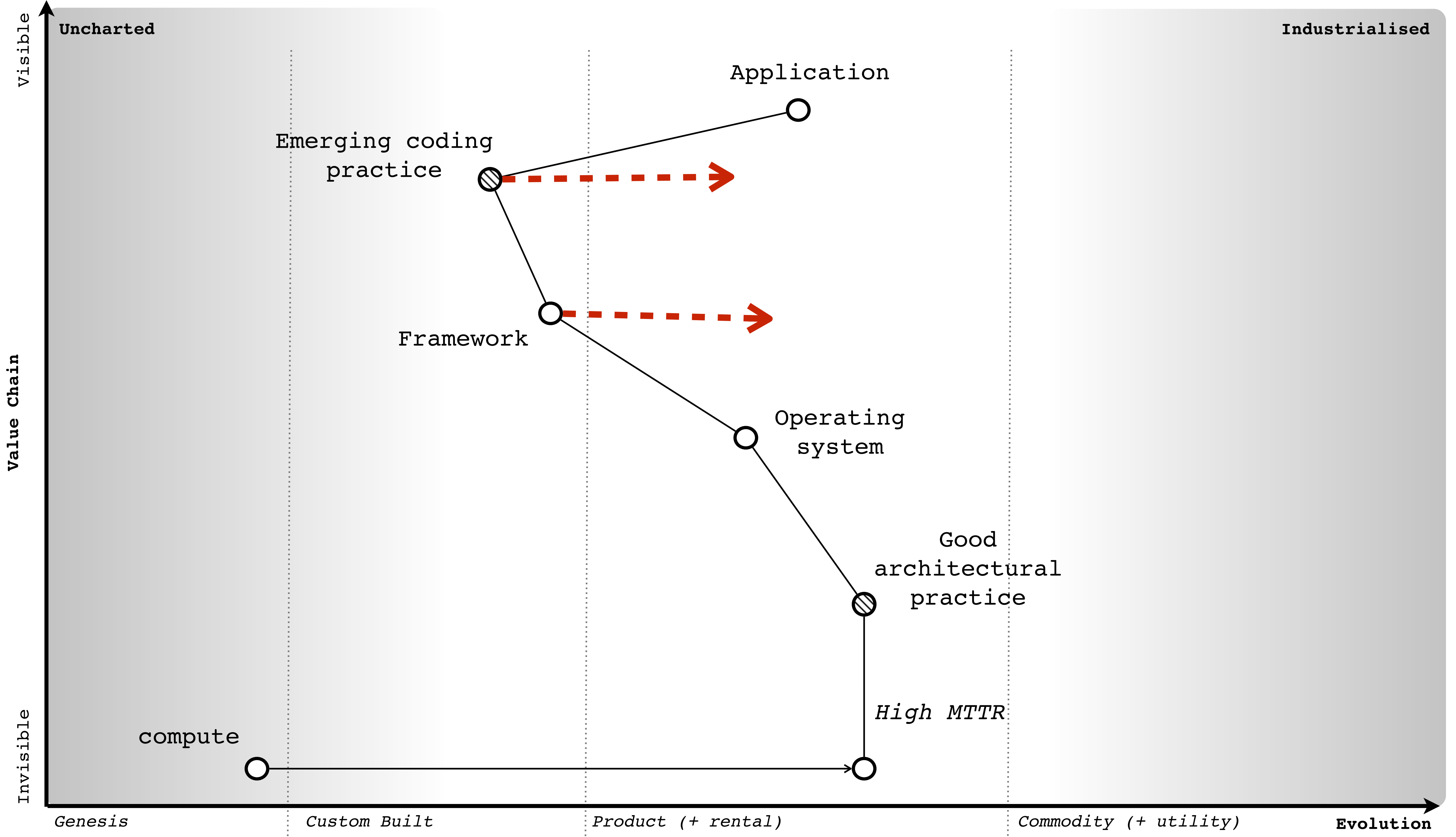

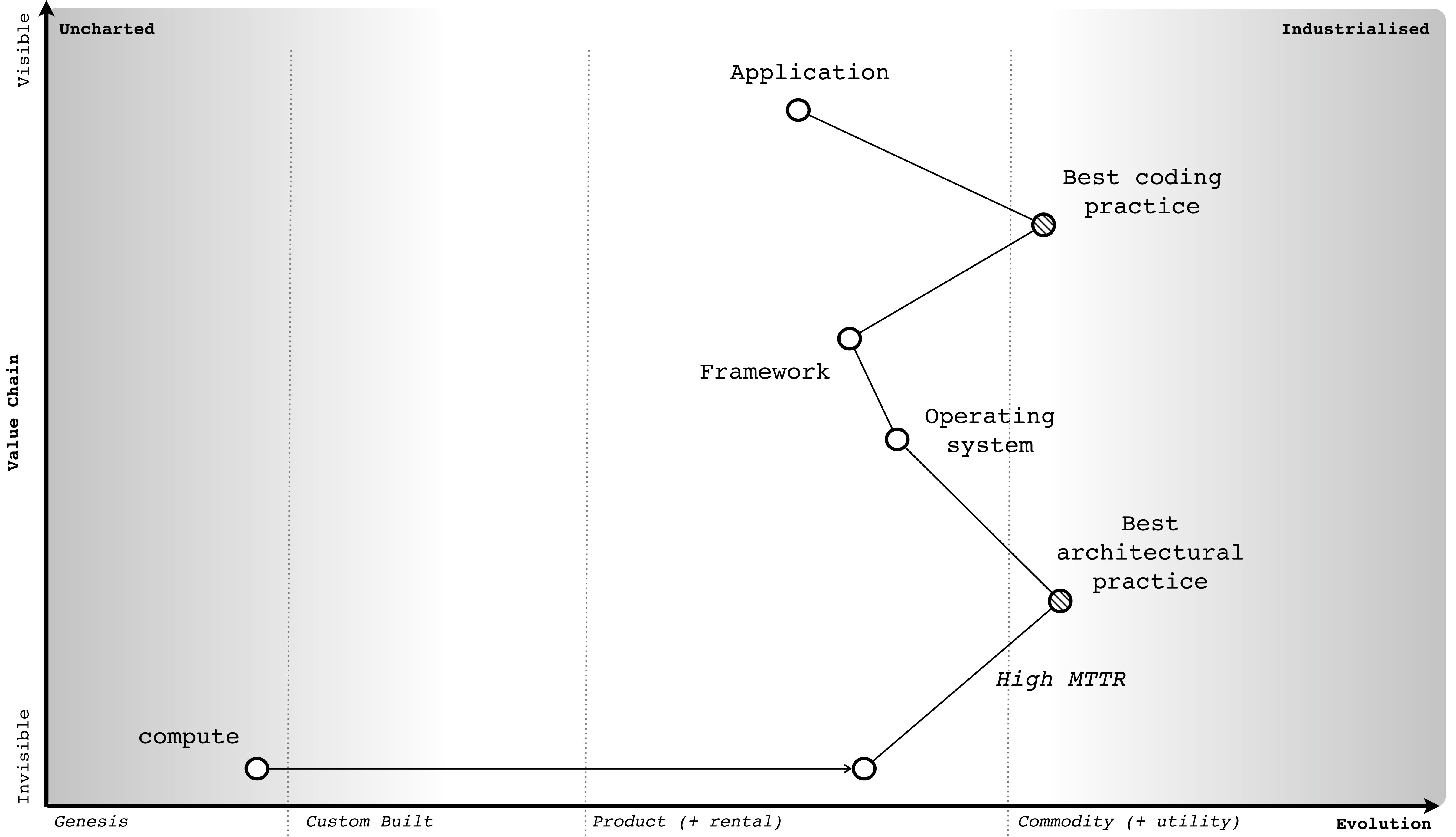



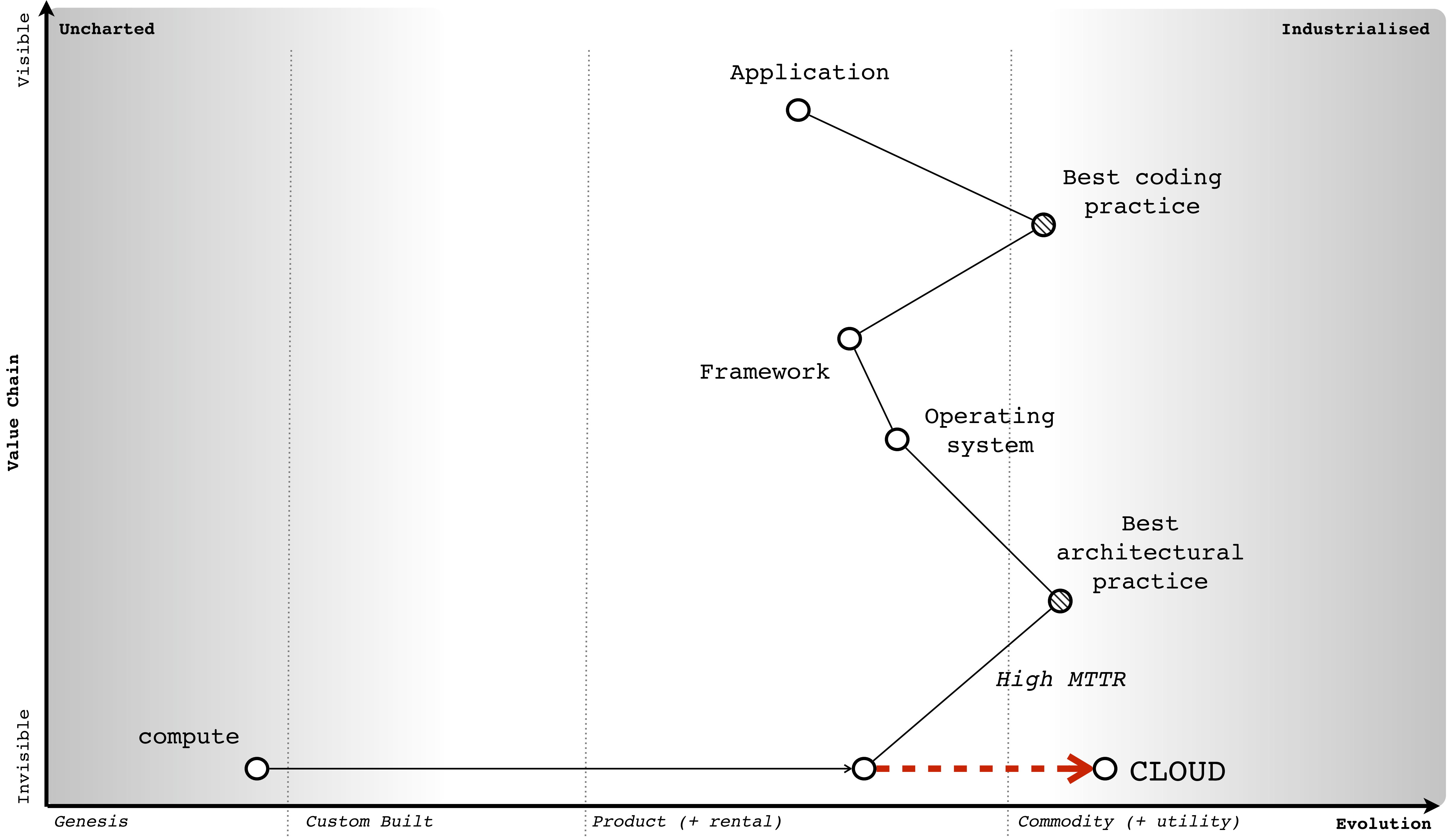

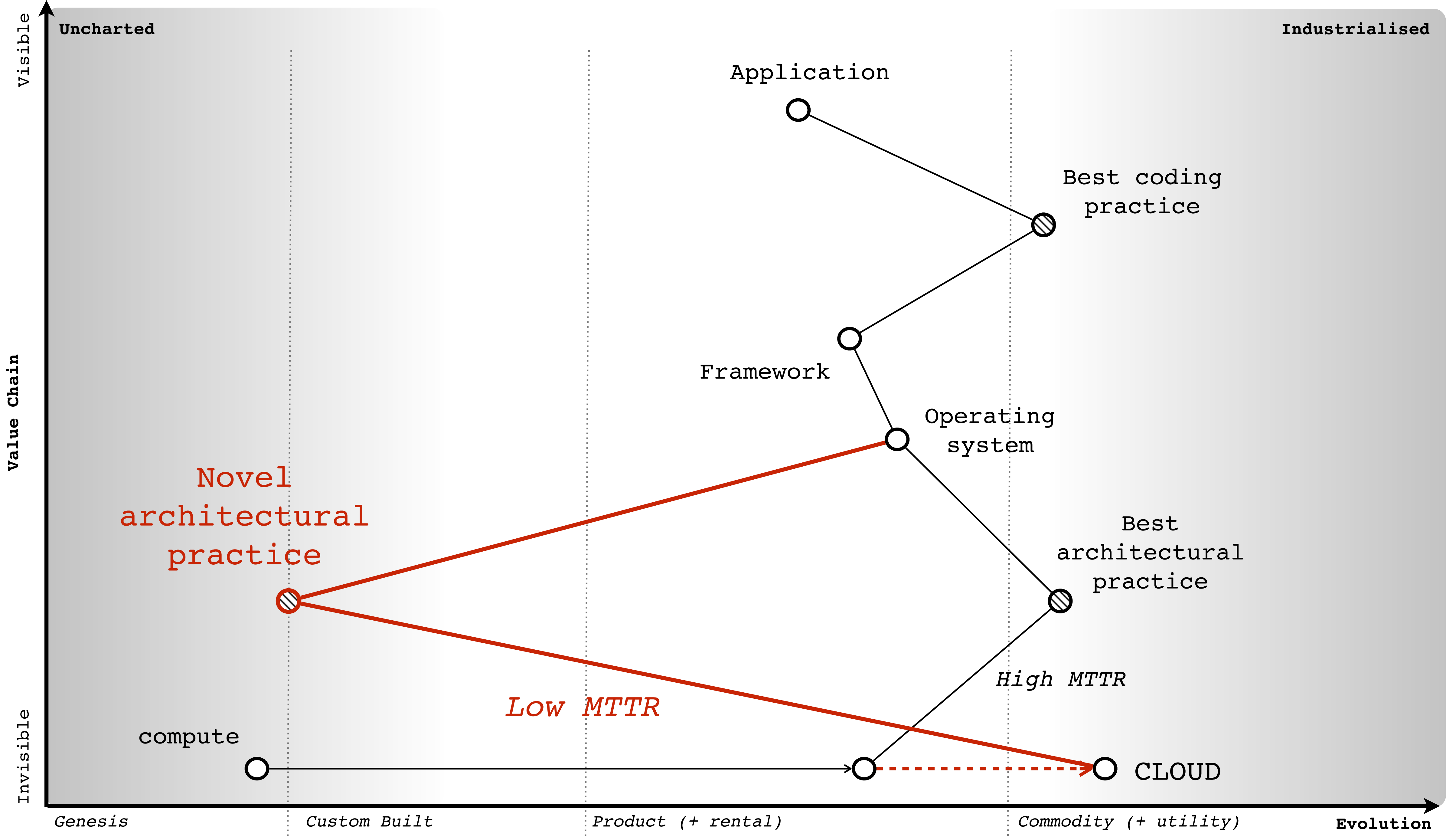



Make my
stuff
"cloudy"

Amazon Cloud Outage Aftermath: Questions, Concerns Linger

By [Andrew R Hickey](#), CRN

May 11, 2011 1:33 PM ET

[Amazon's cloud outage](#) shook the cloud computing industry to its core last month, and at Interop Las Vegas 2011 a panel of cloud experts examined the fallout and the lasting impact of Amazon (NSDQ:[AMZN](#))'s cloud outage.

Amazon's cloud services went down for several hours, and in some cases days, on April 21 after an issue with its Elastic Block Store (EBS) service got stuck in a "re-mirroring storm" in its North Virginia data center. The hiccup knocked several Amazon cloud users offline,

RECENT ARTICLES



Amazon's Not A Outages In The

Amazon's cloud outage
last. Here we look at
within the last year.



Amazon Cloud Learned

Three ginger cats are dressed as the Three Kings. The cat on the left wears a black hat and a red robe. The middle cat wears a red hat and a red robe. The cat on the right wears a red hood and a red robe, holding a scroll. A white speech bubble with a black border is positioned on the left side of the image, containing the text "The end of cloud is nigh ...".

The end of
cloud is
nigh ...



Shouldn't
our
architecture
evolve as
well?



Burn
him!

Heretic

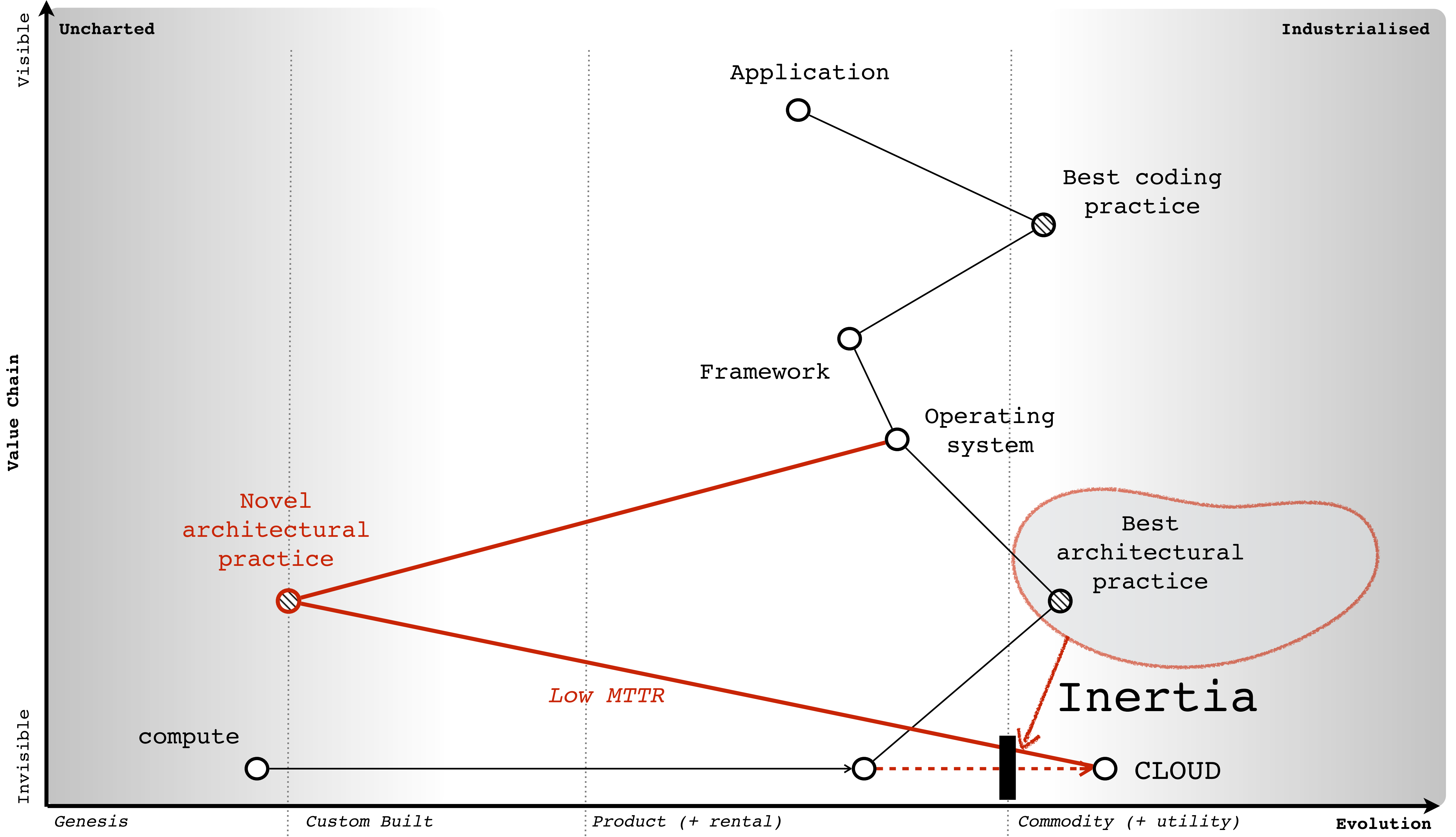

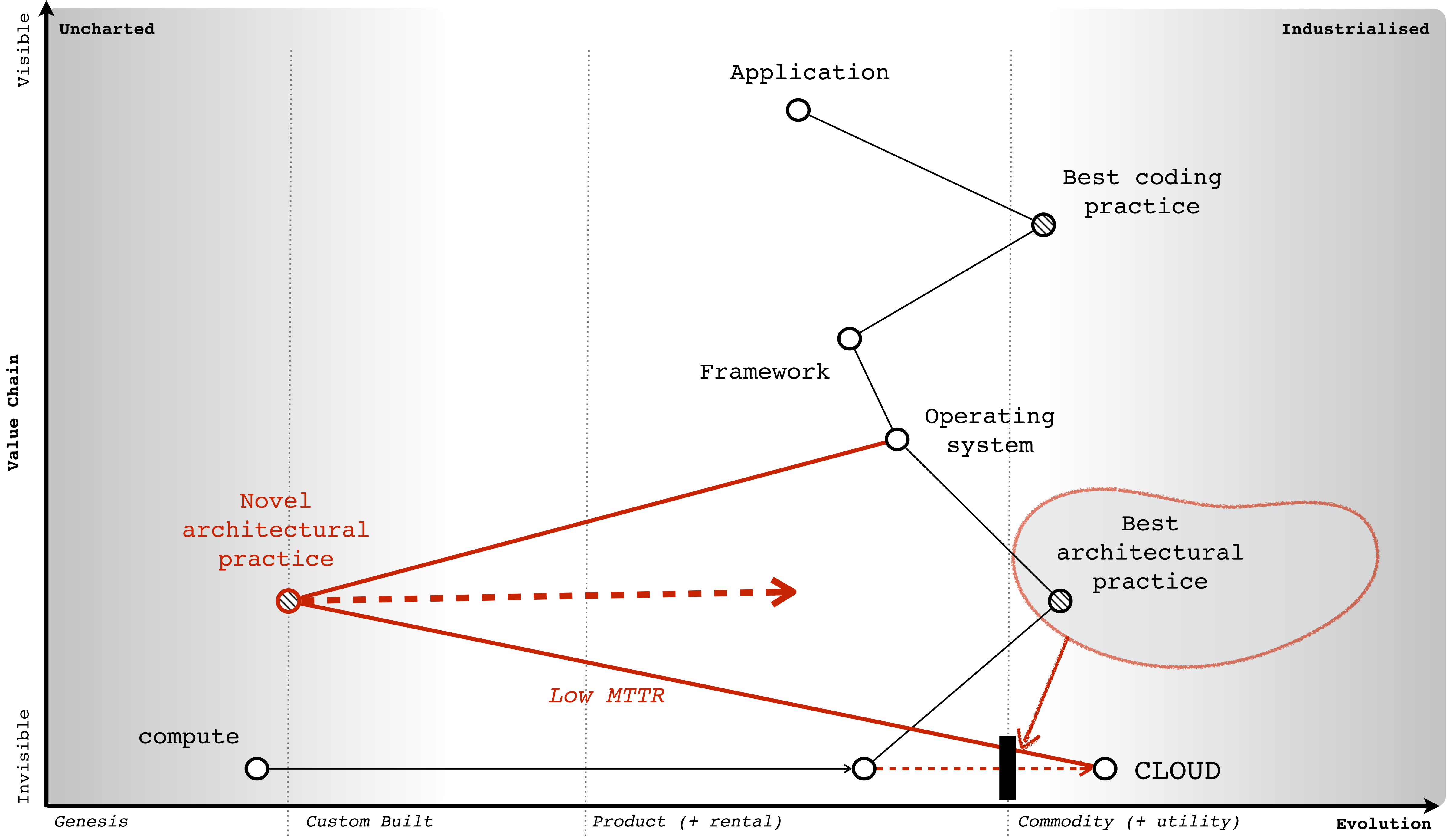

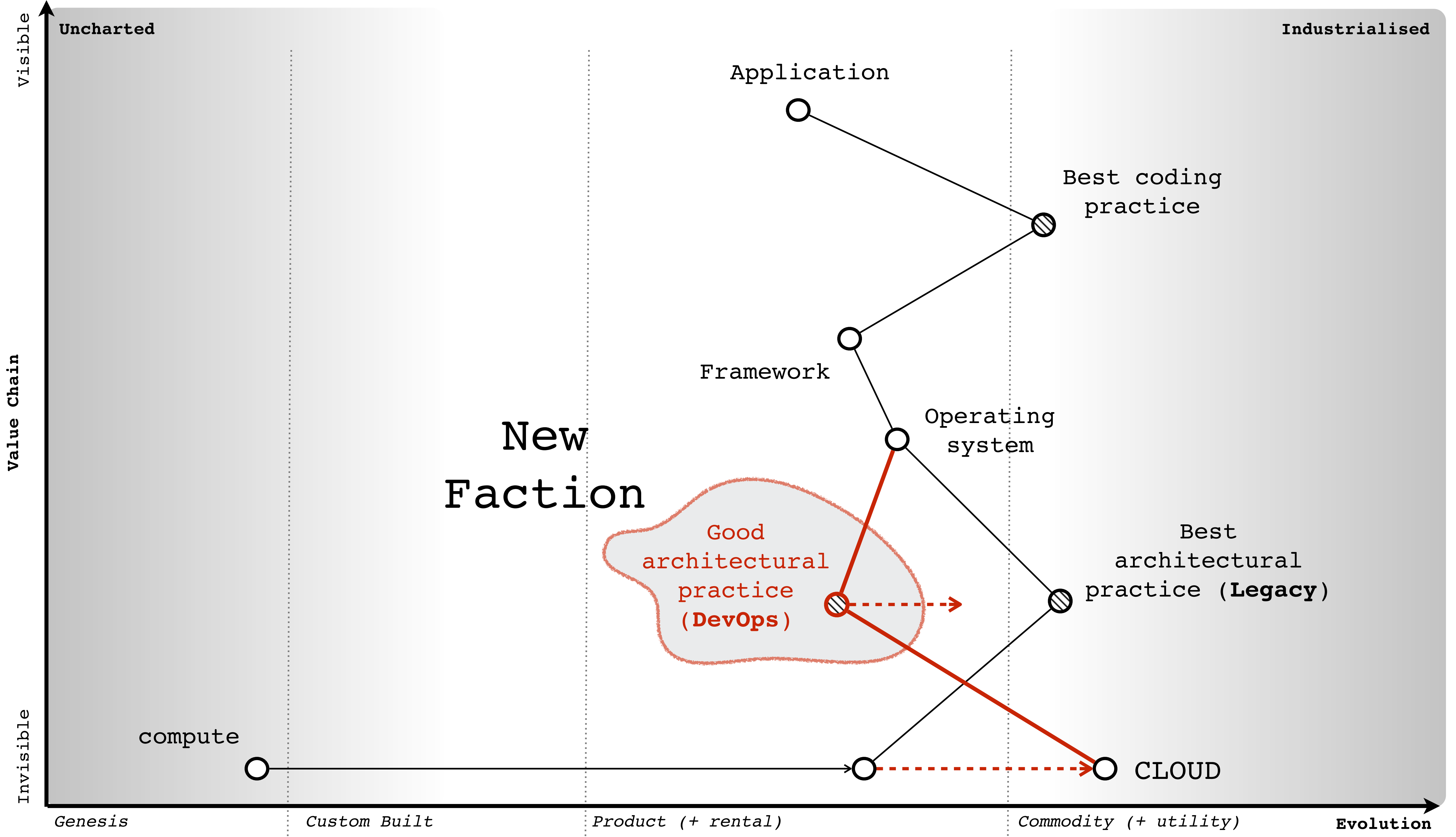

New Faction

Good architectural practice (DevOps)

Best architectural practice (Legacy)

CLOUD

A photograph of three ginger cats dressed as the Three Kings. They are wearing red, hooded robes and red hats. The cat on the left is wearing a black hat. The cat in the middle is wearing a red hat with a long brim. The cat on the right is wearing a red hat and a gold cross necklace. A white speech bubble is on the left side of the image, containing text.

It's all about user
needs, iterative
cycles, automation,
collaboration, ...



So was ITIL



Burn
him!

Heretic

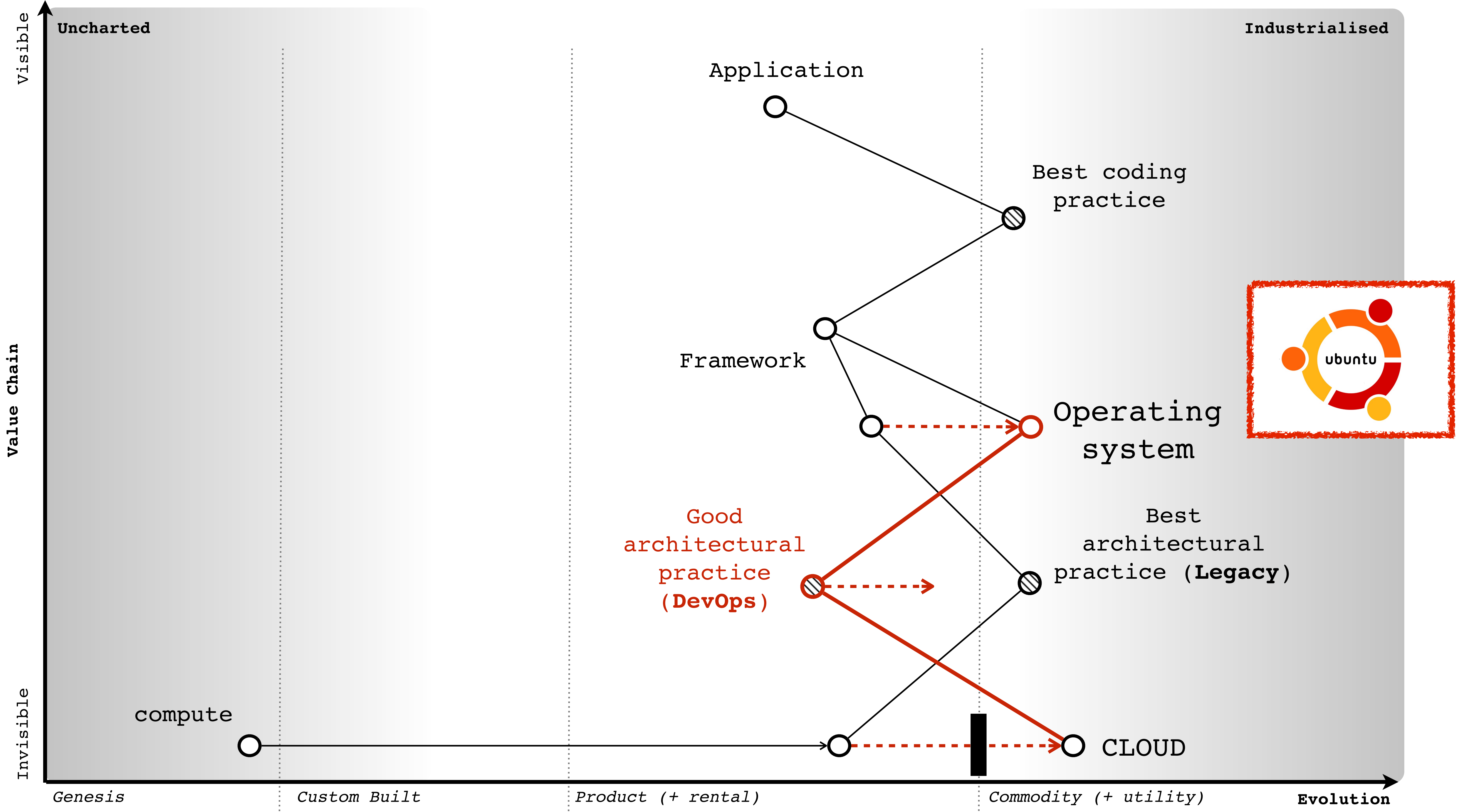

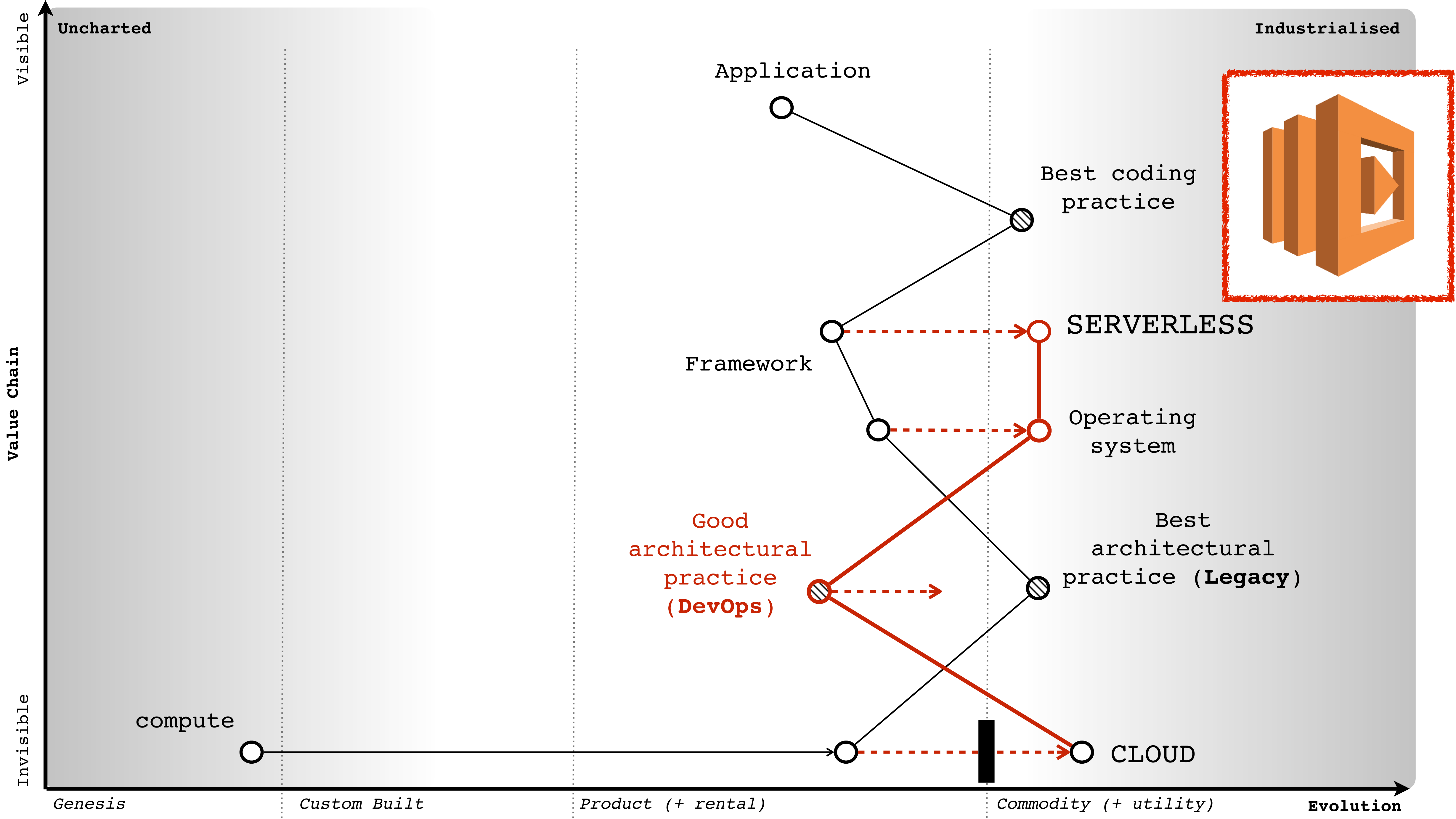



Some Of The Customers Running Serverless On AWS



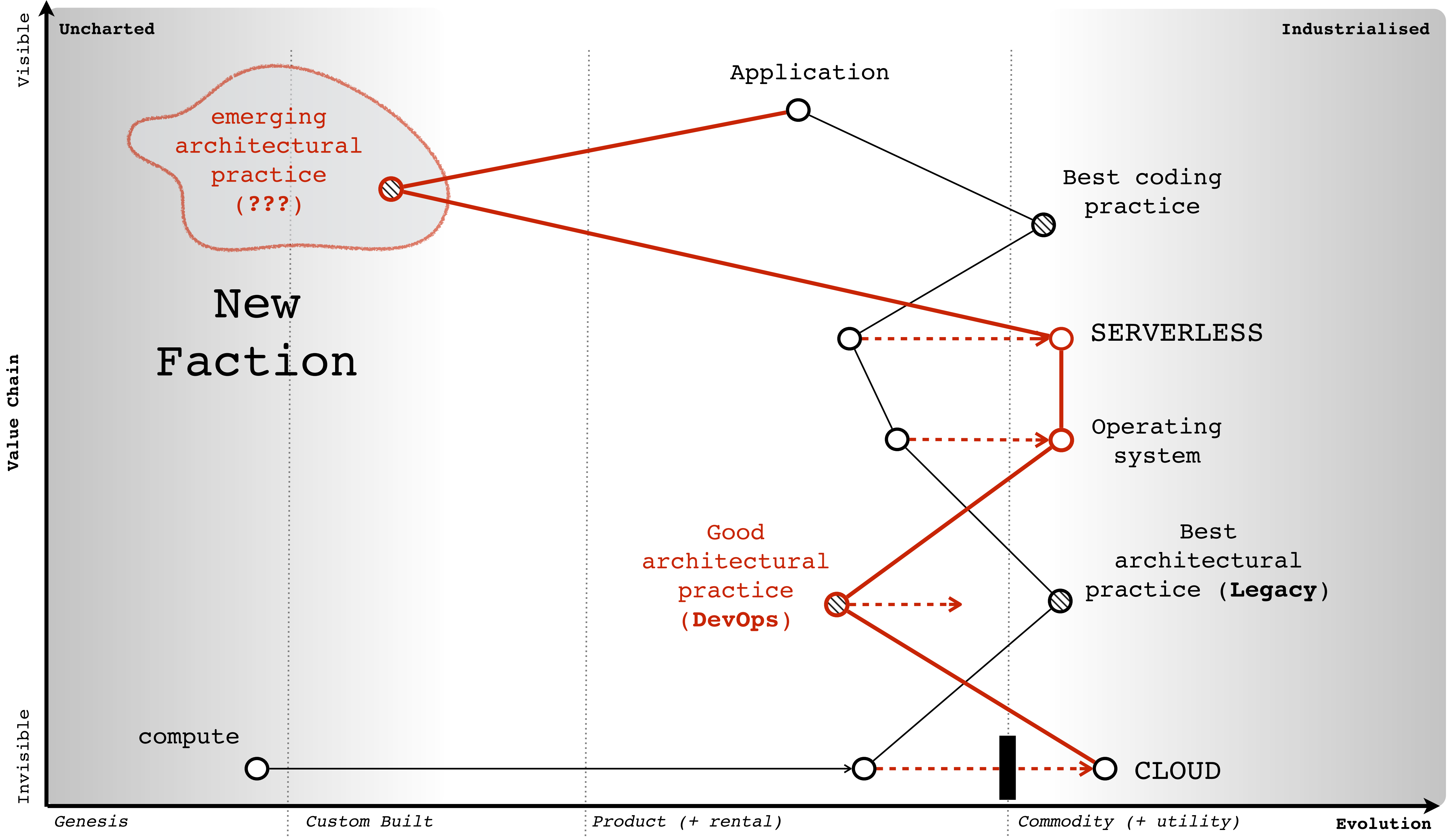

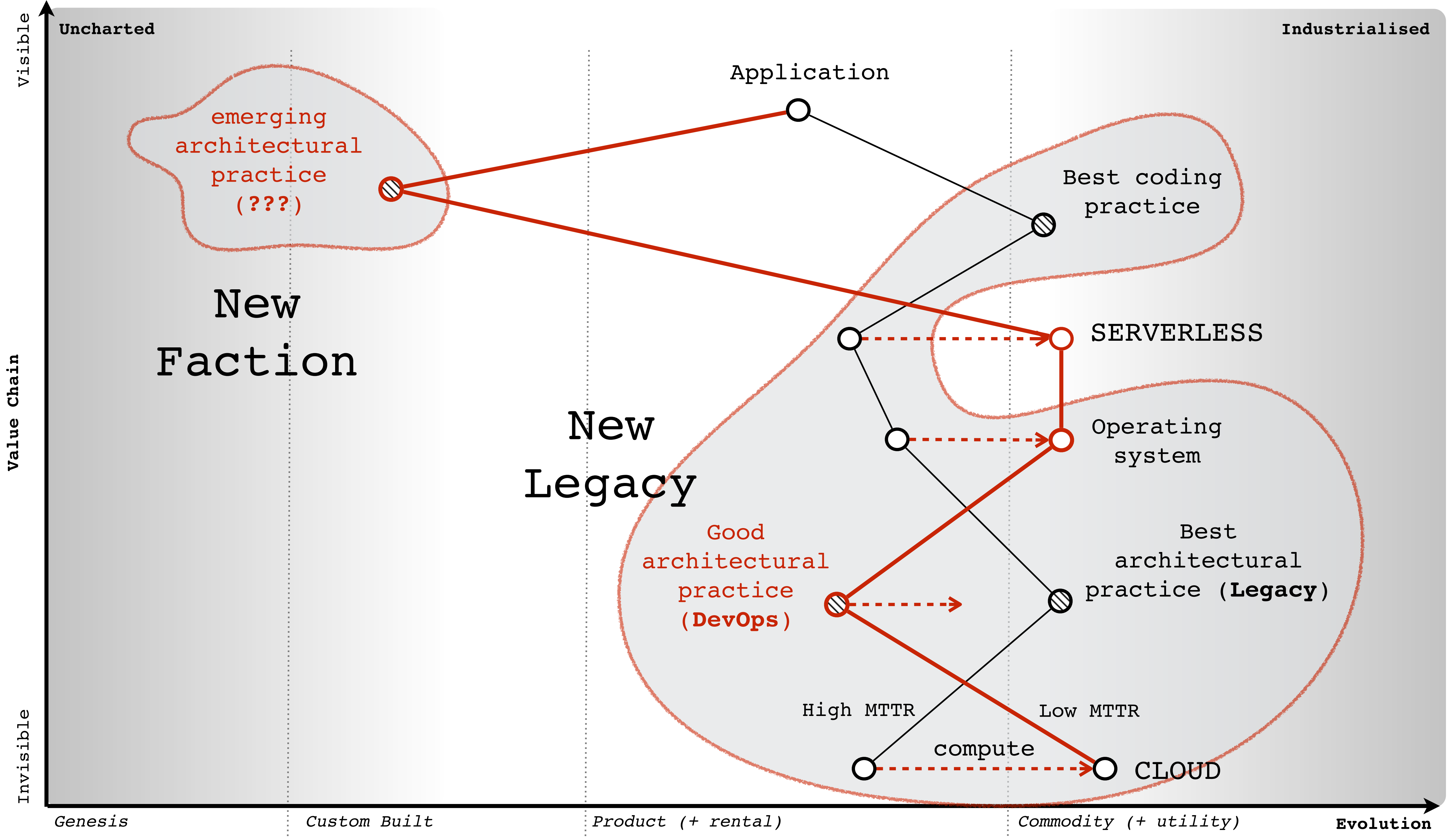

emerging architectural practice (???)

New Faction

New Legacy

Good architectural practice (DevOps)

Best coding practice

SERVERLESS

Operating system

Best architectural practice (Legacy)

High MTTR

Low MTTR

compute

CLOUD

Genesis

Custom Built

Product (+ rental)

Commodity (+ utility)

Evolution



DevOps is
the new
legacy?



Burn
him!

Containers
FTW

FaaS and Furious

by Forrest Brazeal

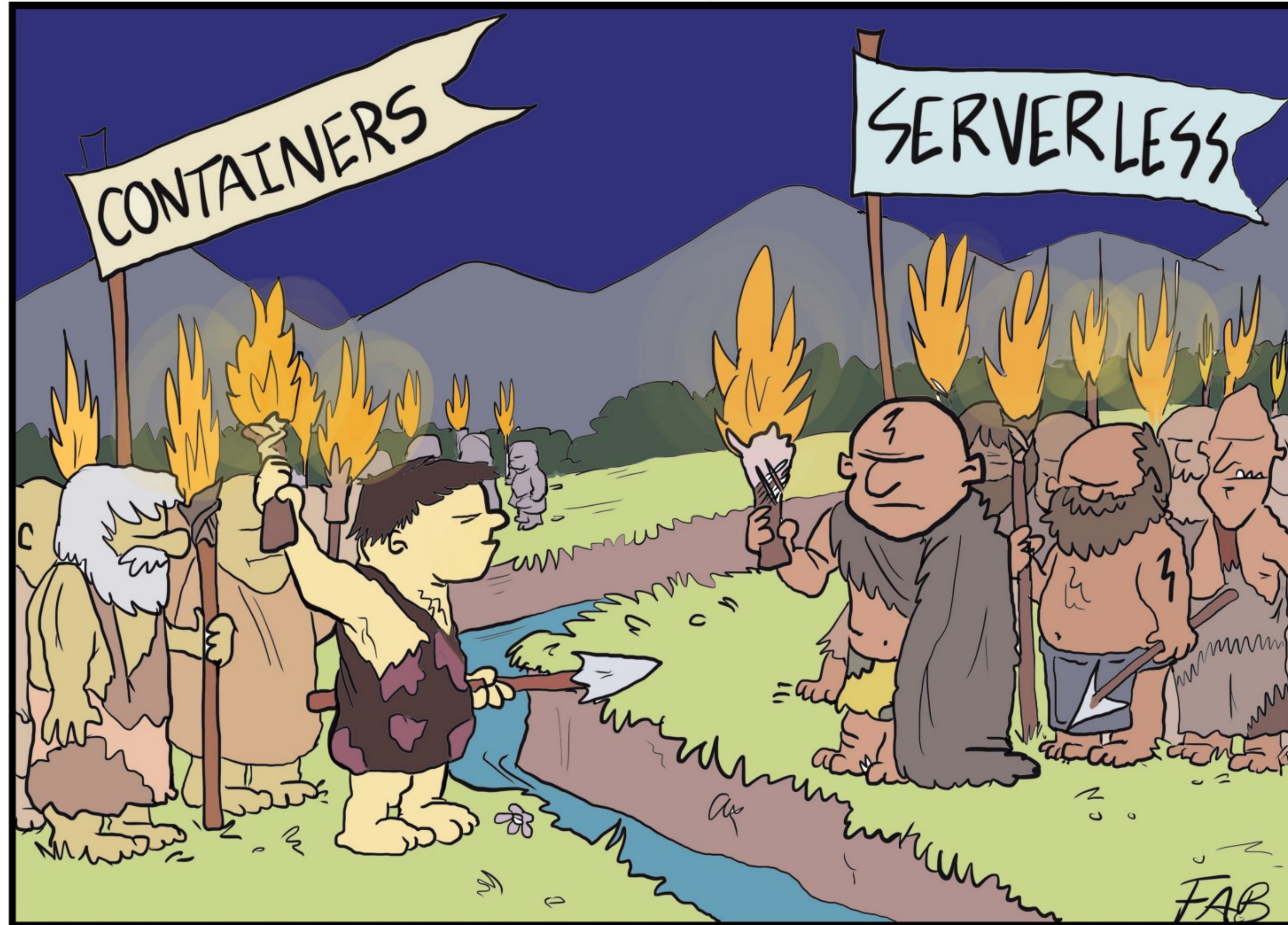

The two tribes regarded each other suspiciously in the glow of their brightly blazing production environments.

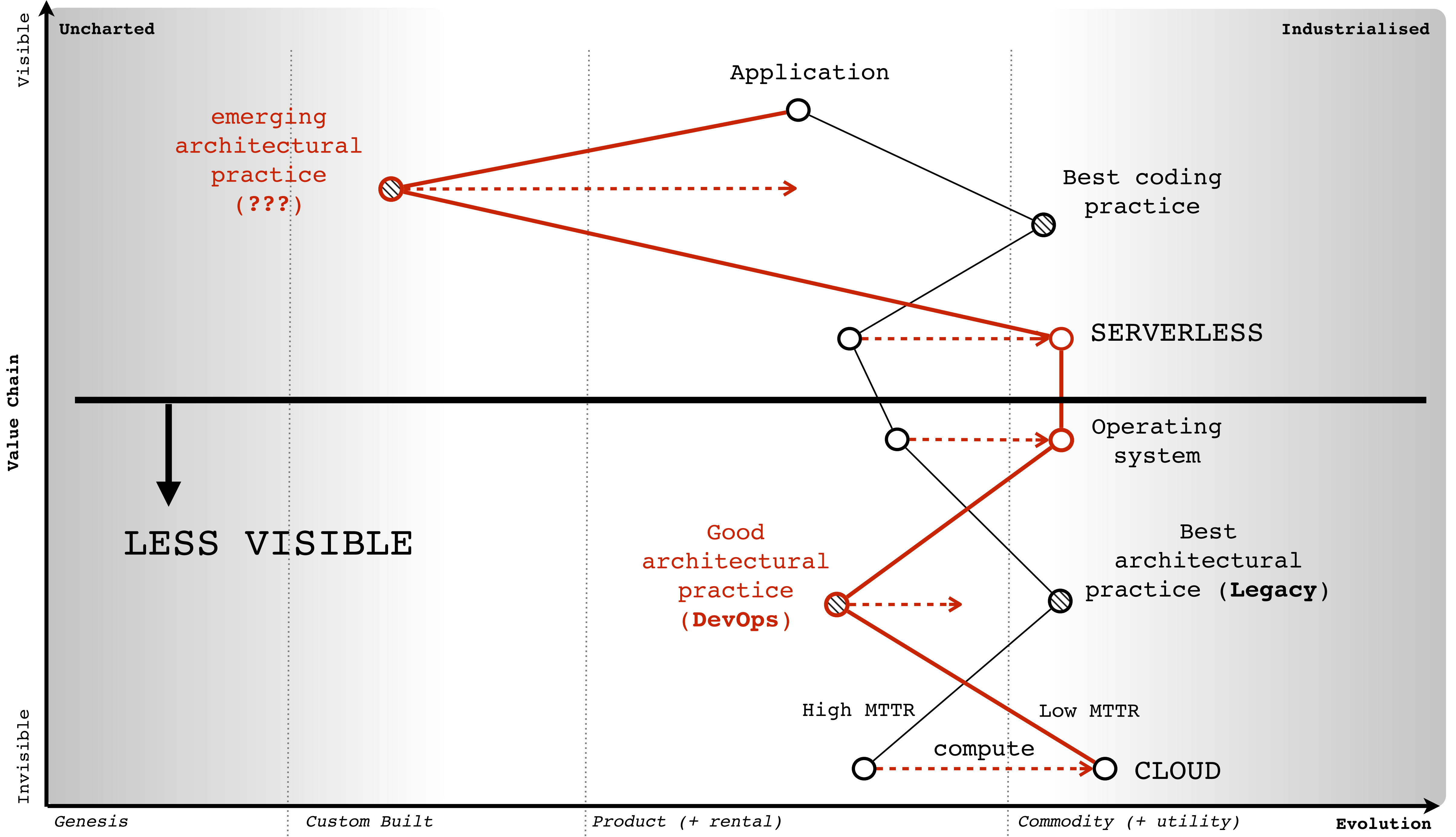

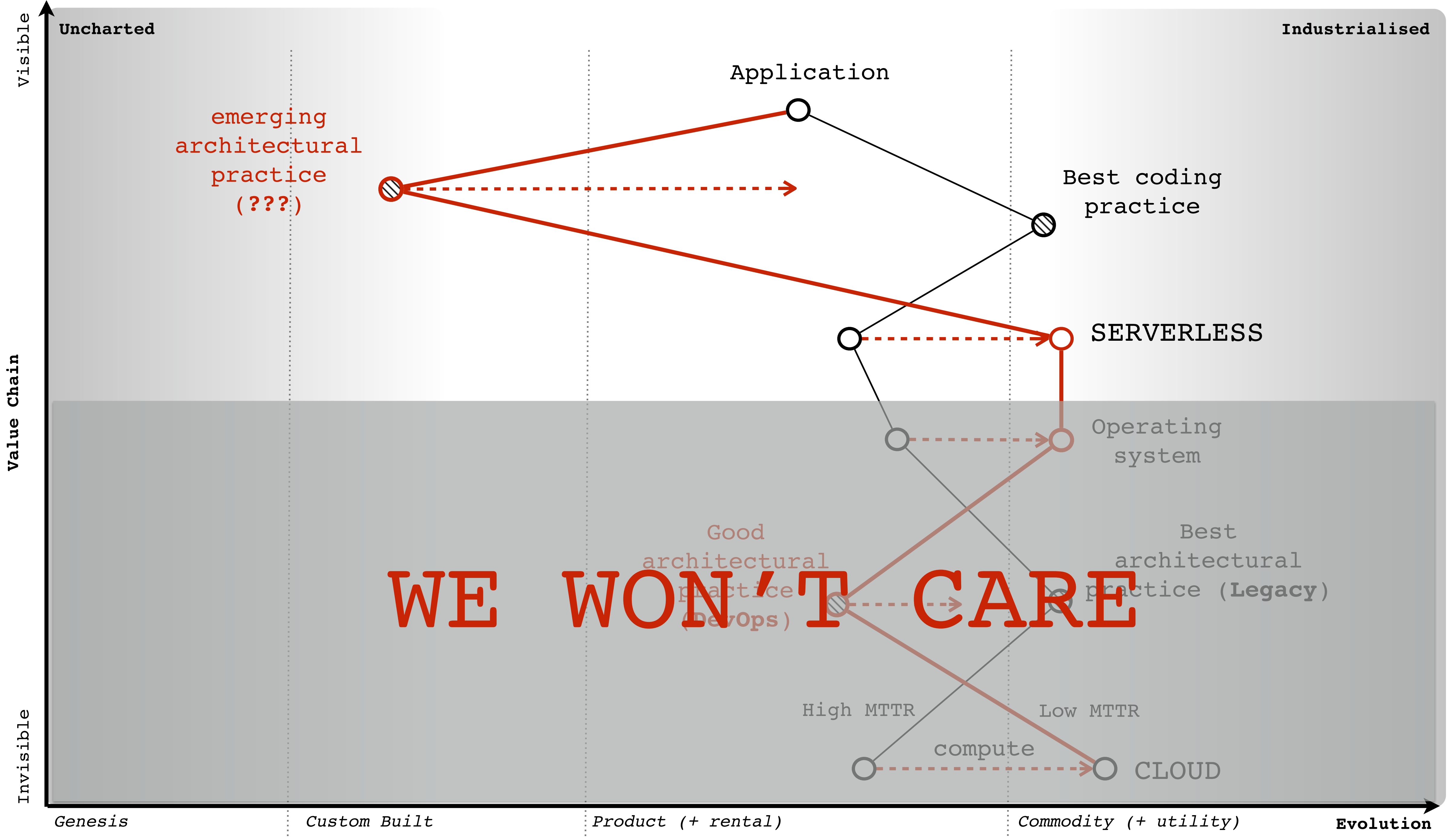

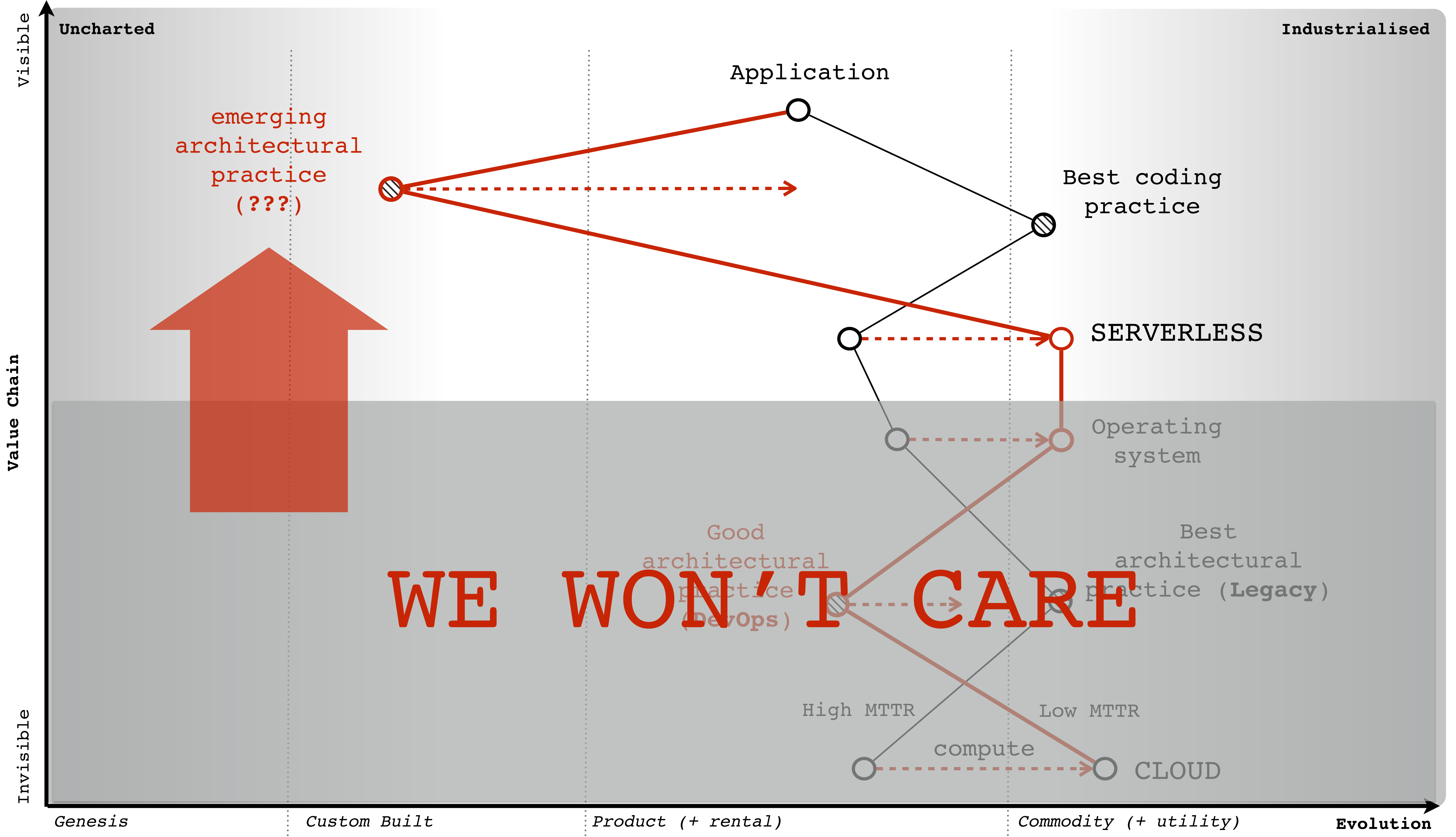

WE WON'T CARE

WHAT PRACTICES?

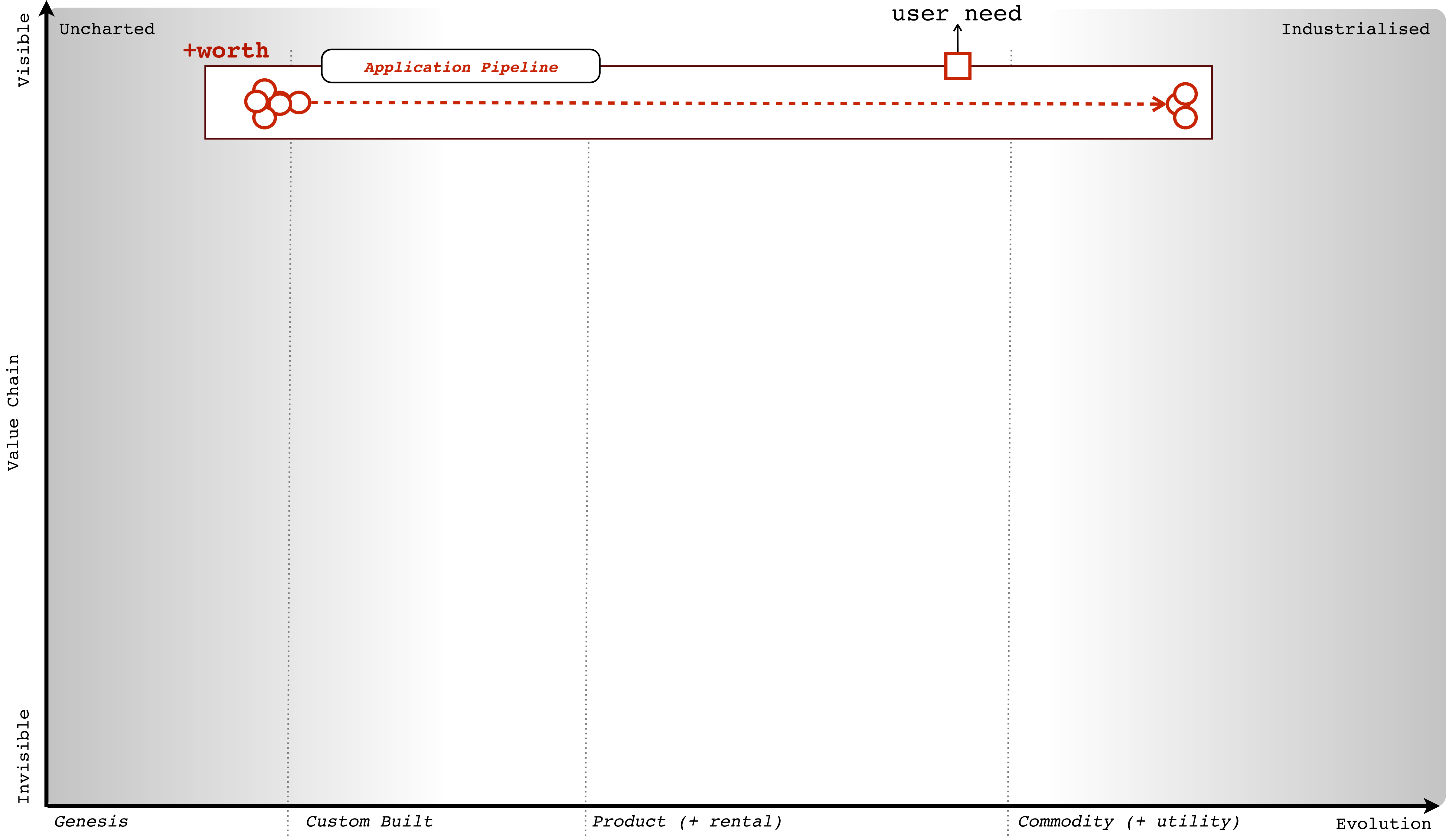

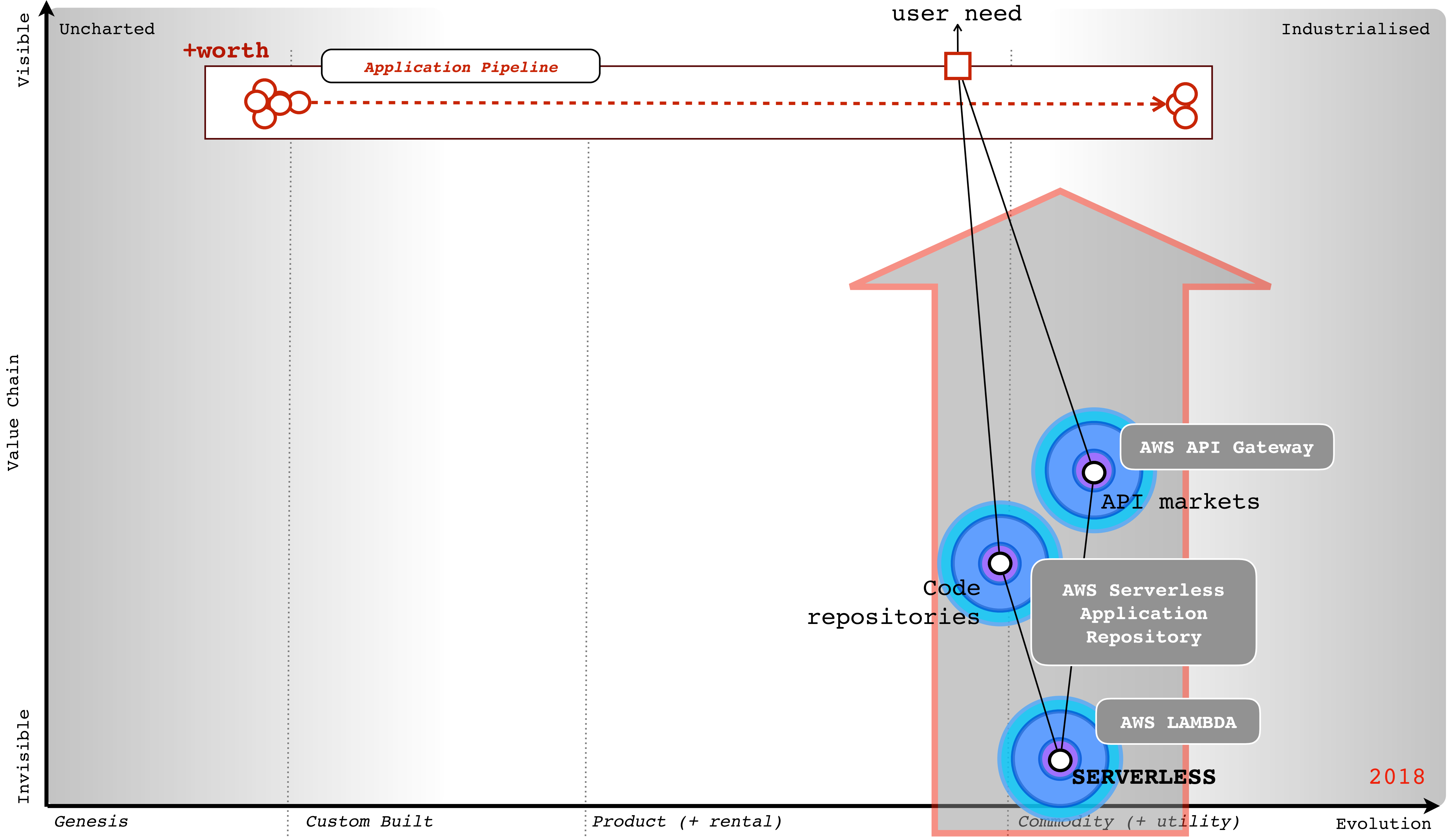

user need

Uncharted

Industrialised

+worth

Application Pipeline

Value Chain

AWS API Gateway

API markets

Code repositories

AWS Serverless Application Repository

AWS LAMBDA

SERVERLESS

2018

Genesis

Custom Built

Product (+ rental)

Commodity (+ utility)

Evolution

Invisible

Visible

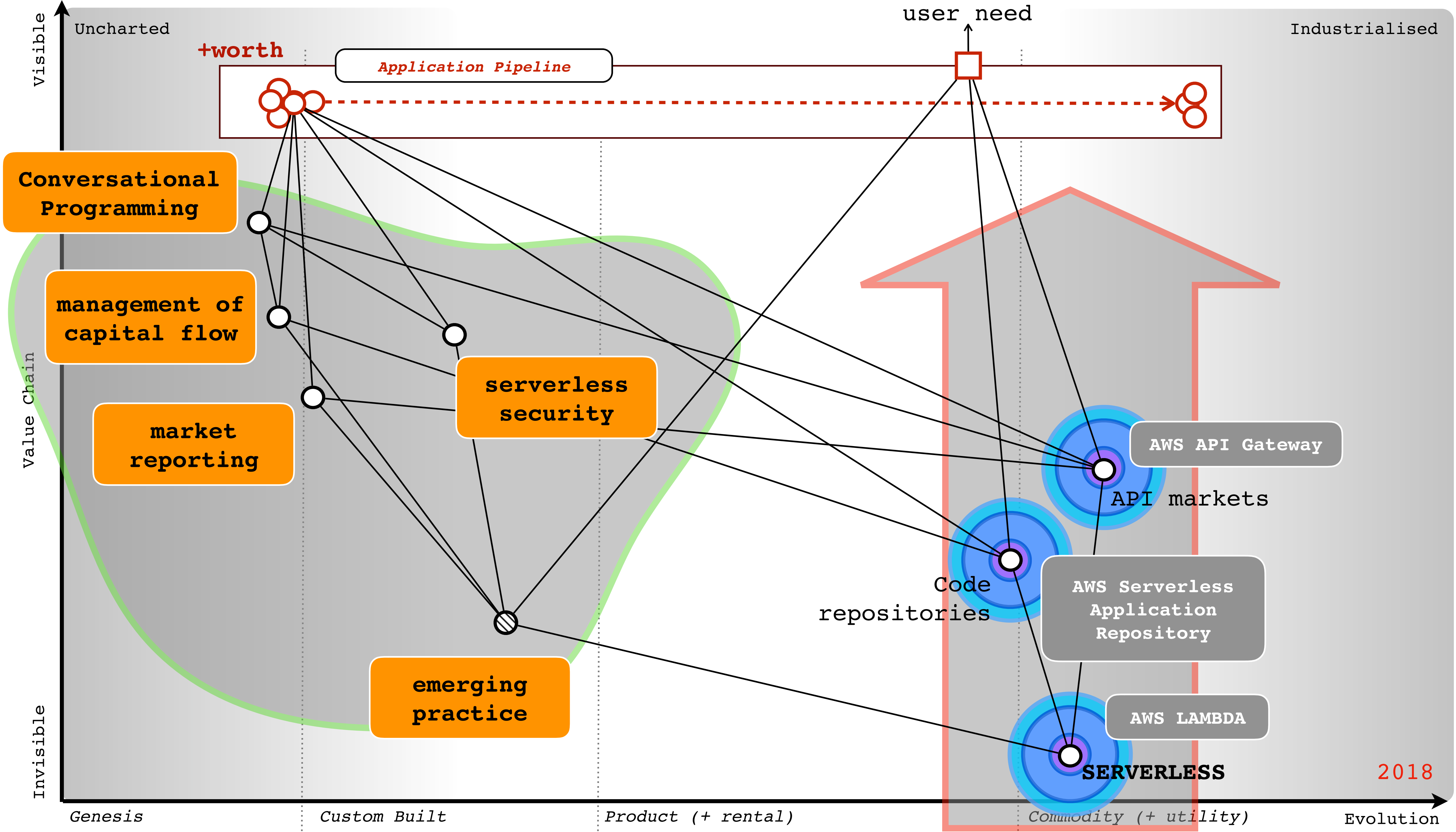

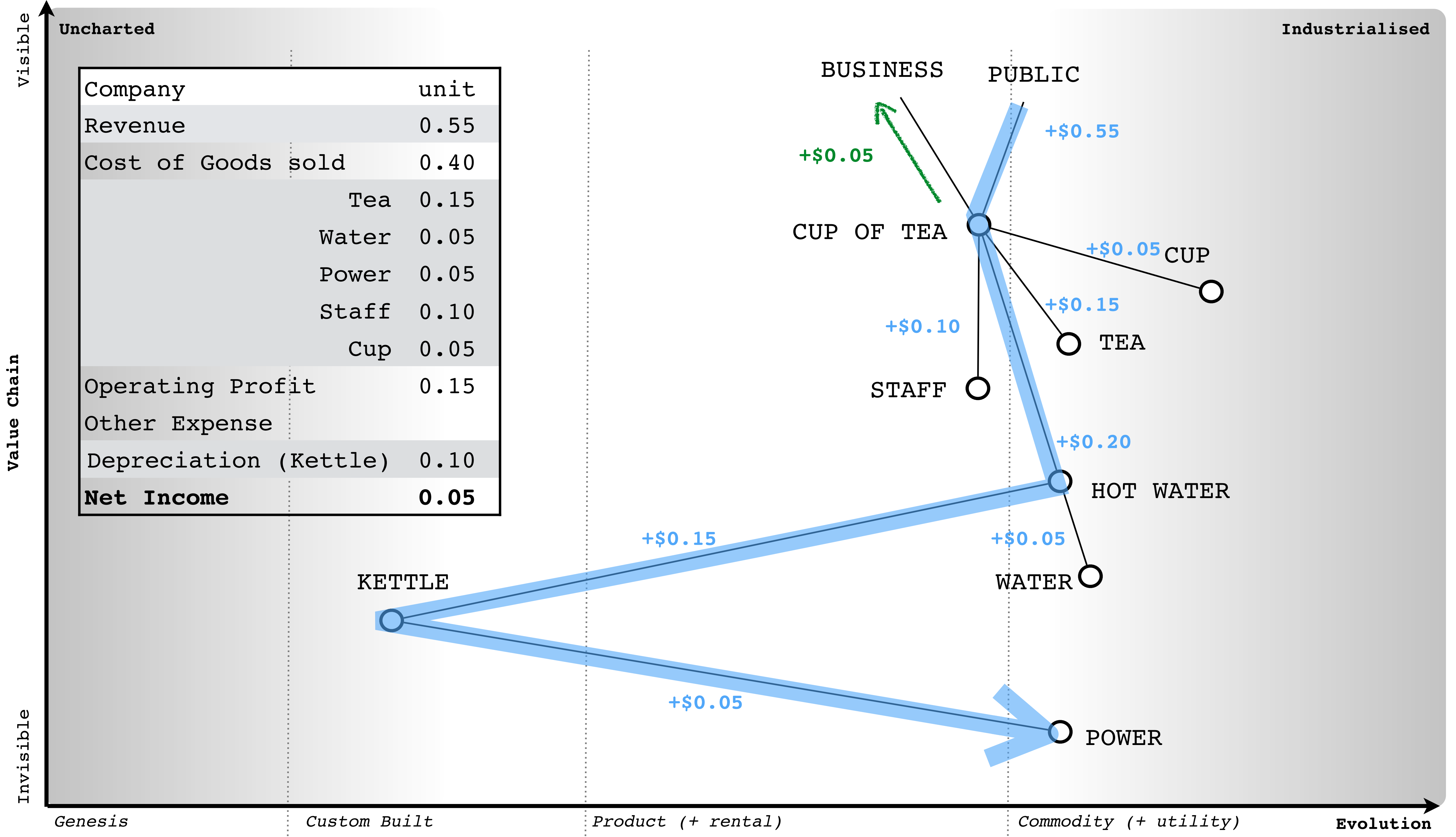

Company		unit
Revenue		0.55
Cost of Goods sold		0.40
	Tea	0.15
	Water	0.05
	Power	0.05
	Staff	0.10
	Cup	0.05
Operating Profit		0.15
Other Expense		
Depreciation (Kettle)		0.10
Net Income		0.05

Genesis

Custom Built

Product (+ rental)

Commodity (+ utility)

Evolution

KETTLE

WATER

HOT WATER

STAFF

TEA

CUP

CUP OF TEA

PUBLIC

BUSINESS

+\$0.55

+\$0.05

+\$0.15

+\$0.10

+\$0.20

+\$0.05

+\$0.15

+\$0.05

+\$0.05

Visible

Value Chain

Invisible

Uncharted

Industrialised

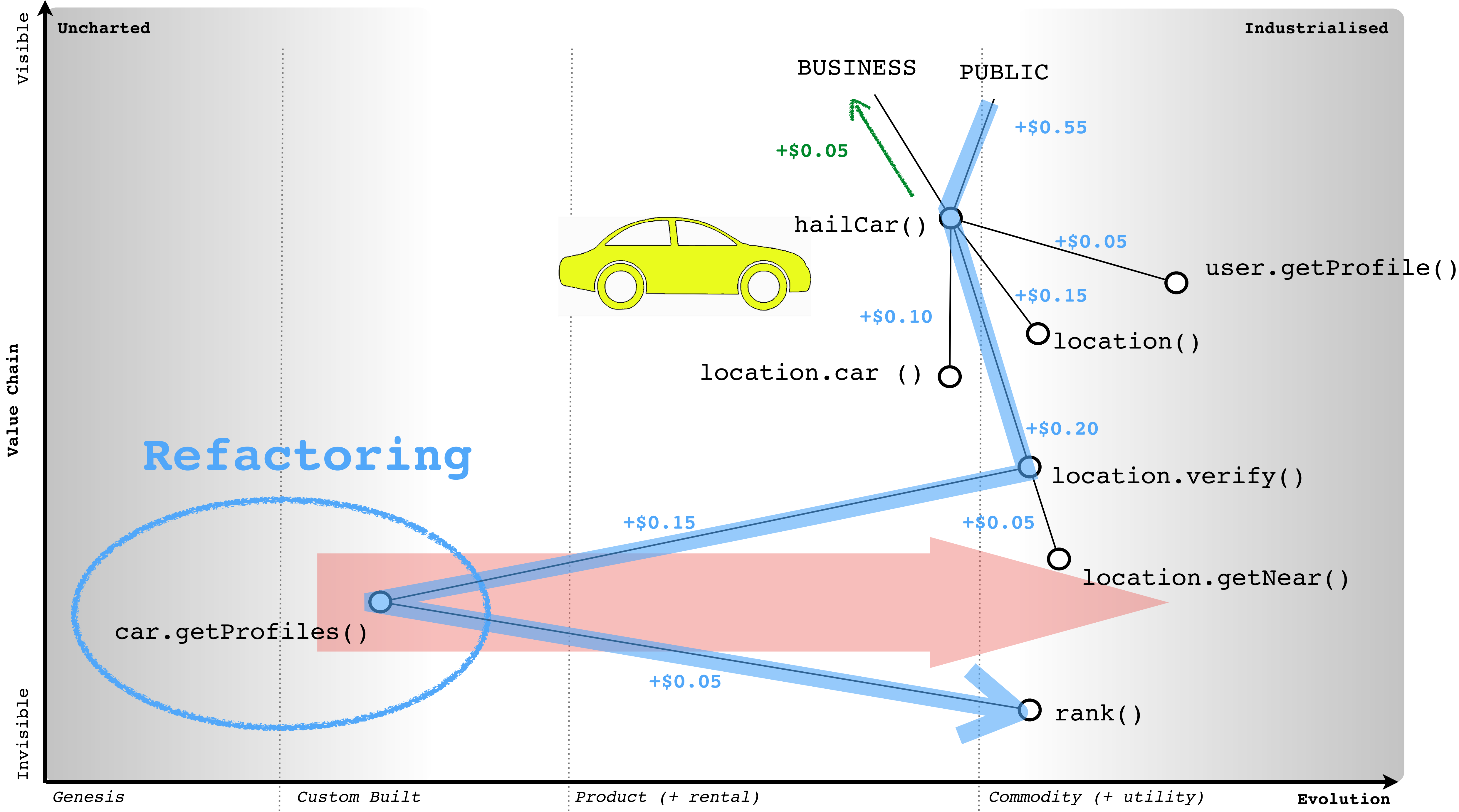

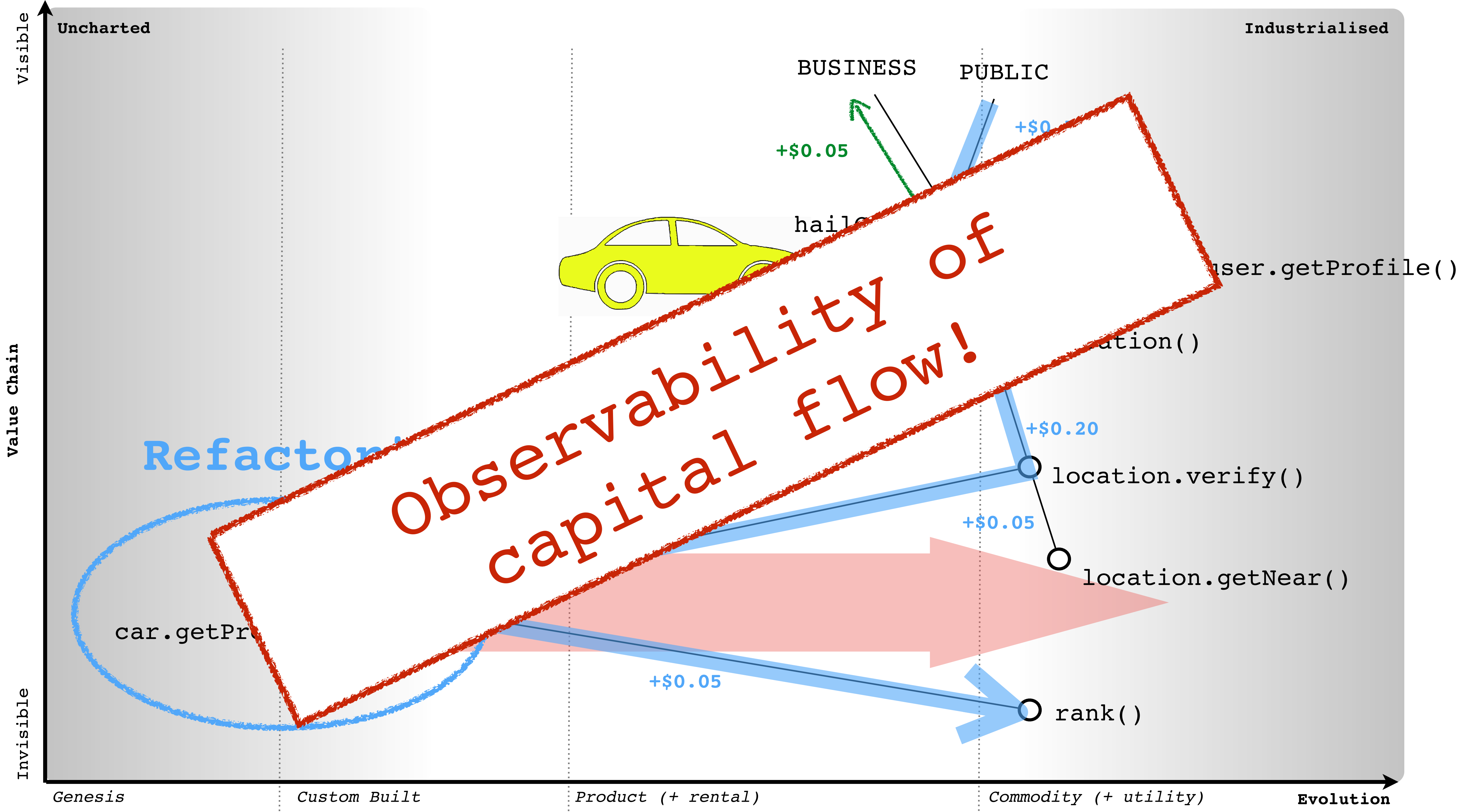

Function Name: massive-calculation

Open in AWS | Last Hour | 24 hours | 7 days

aws:147457102604 | python3.6 | us-east-1

Memory Size: 128MB | Code Size: <0.01MB | Timeout: 20 seconds | Last Modified: 4 months ago

Description: Demo environment: Out of memory

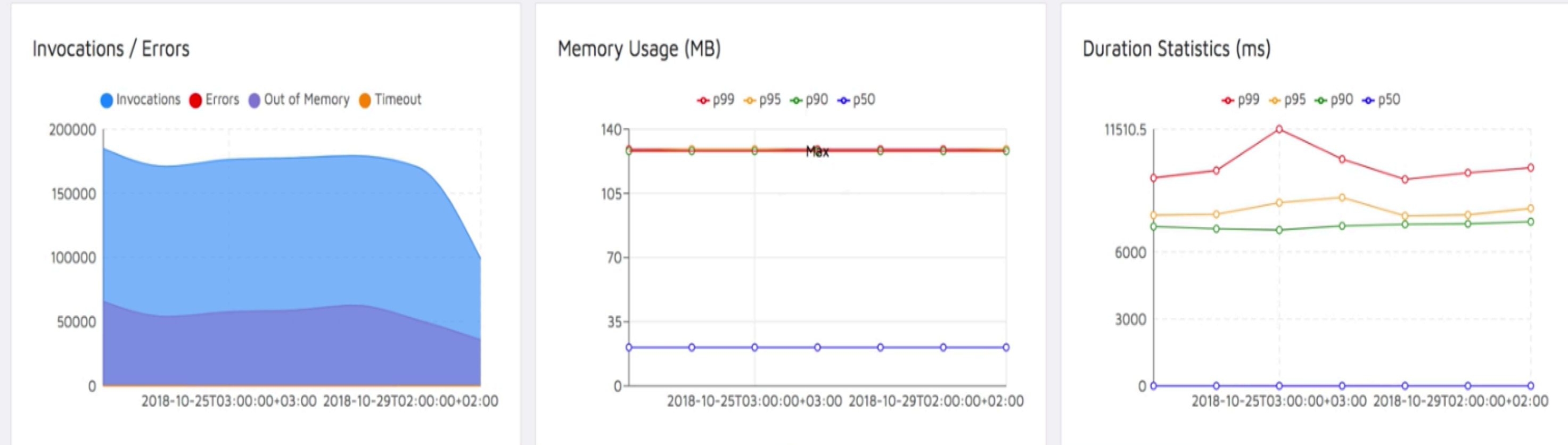

Functions (26)

Export as CSV | 24 hours | 7 days | Search by function name, region or runtime

Function Name	Runtime	Region	Invocations	Errors	Timeouts	Out of Memory	Last Invocation	p50 Duration	Monthly Cost
blog-site-app-prod-Request-Processor	python3.6	us-east-1	9,605,316	1,894,445	3,990	0	13 hours ago	426.59ms	\$3399.80
blog-site-app-prod-Post-Analysis	python3.6	us-east-1	8,318,982	5,737,123	0	0	13 hours ago	21.21ms	\$383.89
blog-site-app-prod-DB-Update	python3.6	us-east-1	2,200,716	0	798	0	13 hours ago	52.88ms	\$132.28
blog-site-app-prod-Post-Validation	python3.6	us-east-1	2,180,052	75,936	798	0	13 hours ago	82.56ms	\$200.12
long-calculation	python3.6	us-east-1	2,044,014	0	641,592	0	13 hours ago	1.09ms	\$218.25
massive-calculation	python3.6	us-east-1	2,010,435	0	0	646,261	13 hours ago	1.01ms	\$394.50
blog-site-app-prod-Kinesis-Analysis	python3.6	us-east-1	1,897,644	0	0	0	13 hours ago	15.07ms	\$48.63
massive-calculation-2	python3.6	us-east-1	1,403,430	0	0	0	13 hours ago	0.36ms	\$22.32
long-calculation-2	python3.6	us-east-1	1,400,847	0	0	0	13 hours ago	0.41ms	\$144.22
process-pipeline-prod-analyze	nodejs8.10	eu-west-1	1,389,654	0	0	0	13 hours ago	19.65ms	\$38.96
process-pipeline-prod-store	nodejs8.10	eu-west-1	1,383,627	0	0	0	13 hours ago	76.13ms	\$155.71
process-pipeline-prod-ingest	nodejs8.10	eu-west-1	1,382,766	0	0	0	13 hours ago	245.10ms	\$334.27
process-pipeline-prod-initiator	nodejs8.10	eu-west-1	1,382,766	0	0	0	13 hours ago	128.83ms	\$176.33
blog-site-app-prod-Operator	python3.6	us-east-1	690,522	0	0	0	13 hours ago	20187.66ms	\$10801.20

Transaction ID: 76ef5dac-58c3-4055-8fb5-beabe3c81797

Architecture View

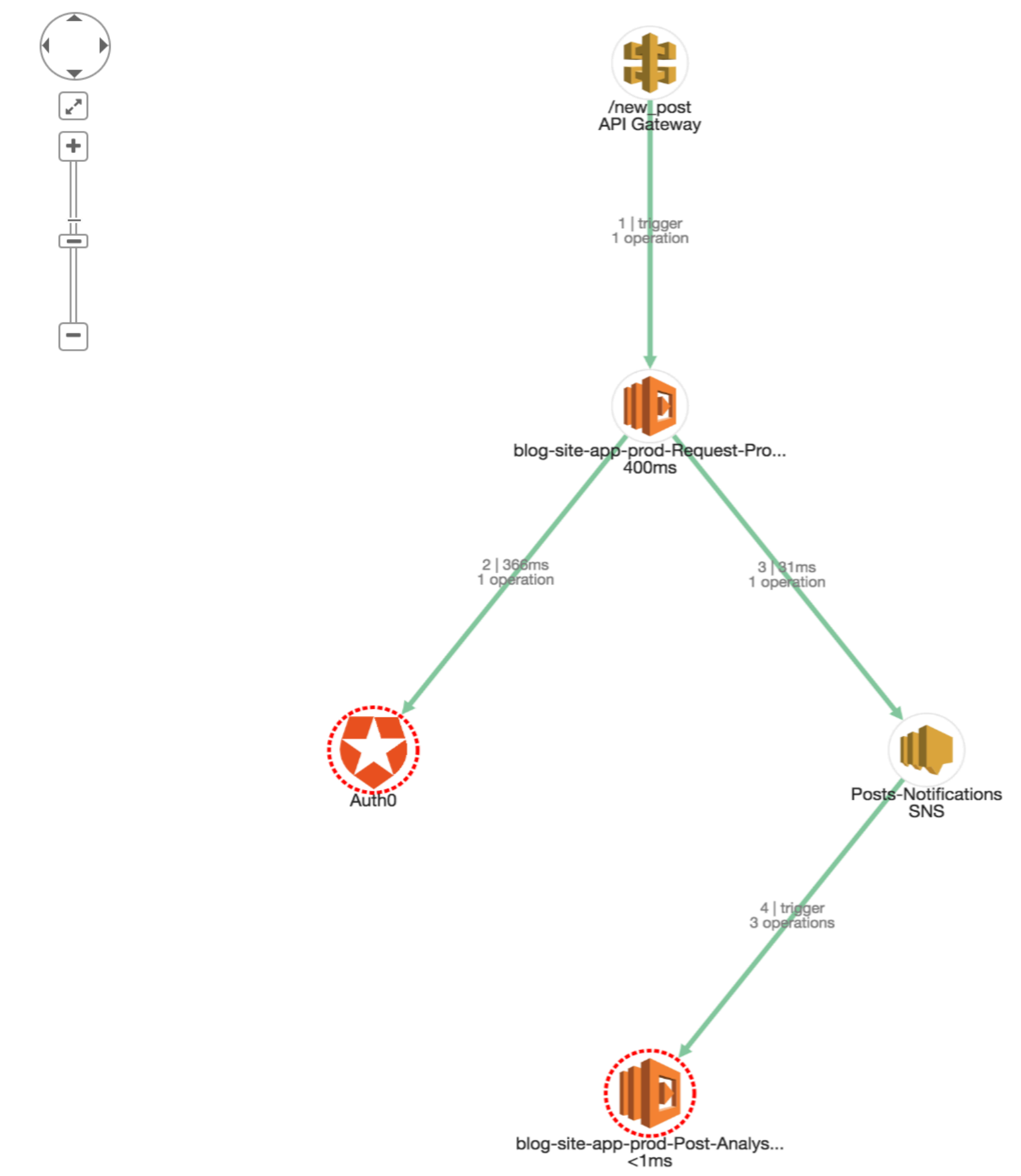

Discover the capital exchange in your serverless applications

Get information on the flow of capital within a transaction and even profitability of smaller features within a transaction.

GET NOTIFIED

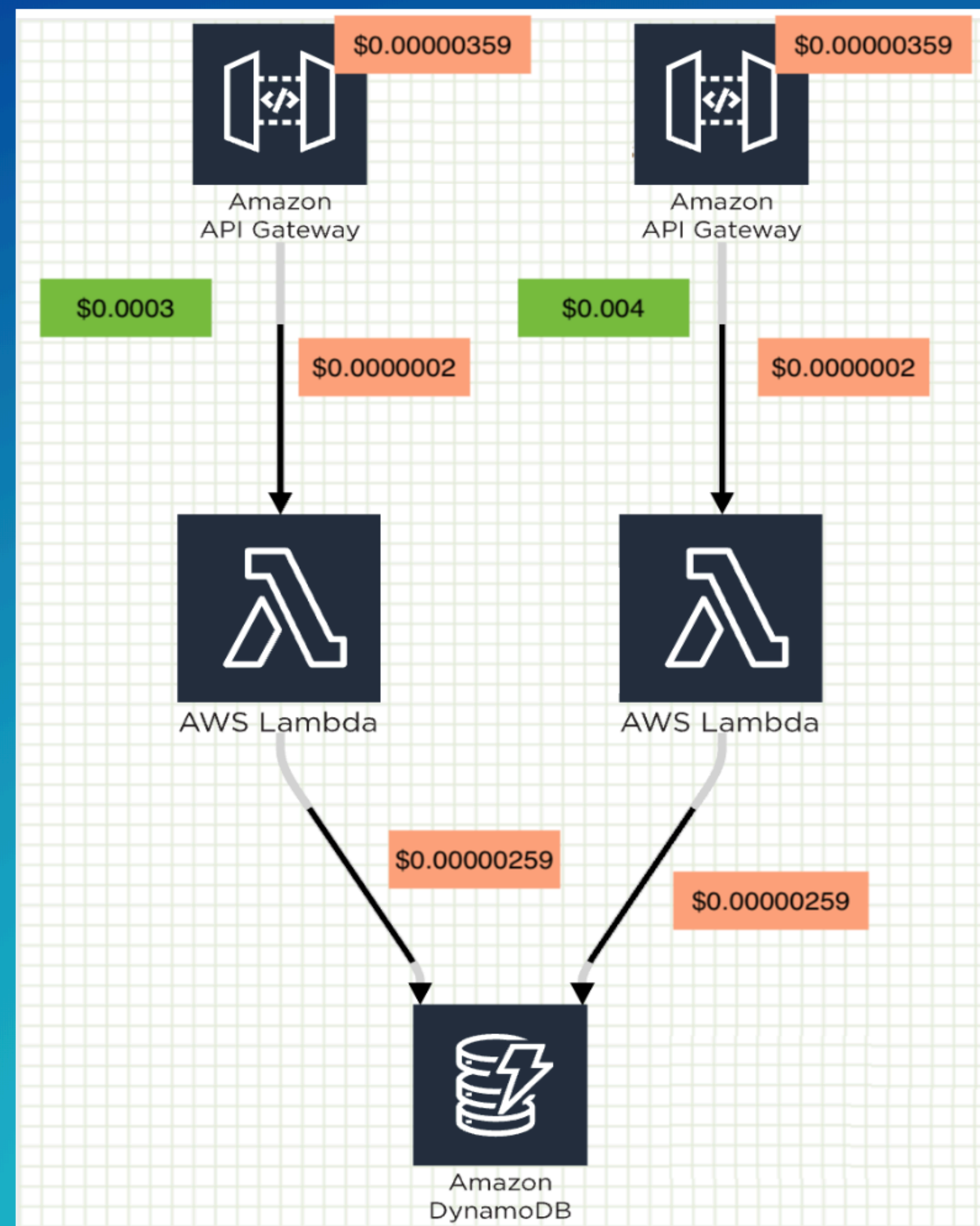

AWS re:Invent

SRV315 - Alexa, Ask Jarvis to Create a Serverless App for Me

Today, we can build and deploy a serverless application in minutes without having to write a line of code using pre-built AWS CloudFormation templates, or services such as the AWS Serverless Application Repository. But can we push the limits even more? In this workshop, we use the Serverless Application Repository combined with Amazon Alexa to create Iron Man's Jarvis look-a-like skill. You learn hands-on with Alexa, Amazon Lex, Amazon SageMaker, and the AWS Serverless Application Repository.

Aleksandar Simovic - Senior Software Engineer, ScienceExchange

Slobodan Stojanovic - CTO @ Cloud Horizon, Cloud Horizon

Additional Information

Session Type: Workshop

Meet your future data centre, head of operations and lead developer ...



RECAP

Strategy

Maps

Communication

SERVERLESS

Anticipation

Organisation

Patterns

Leadership

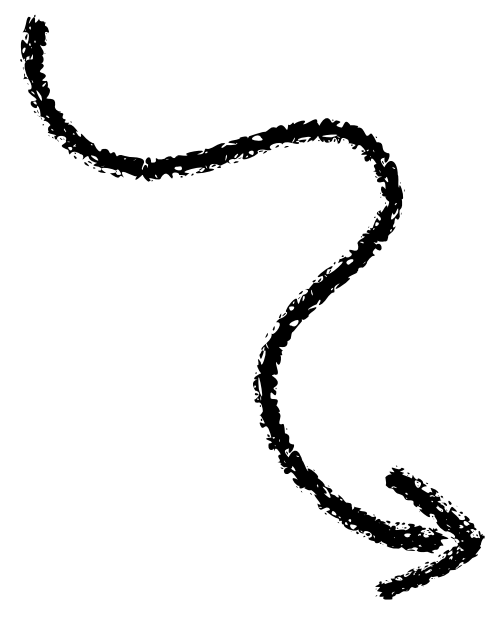
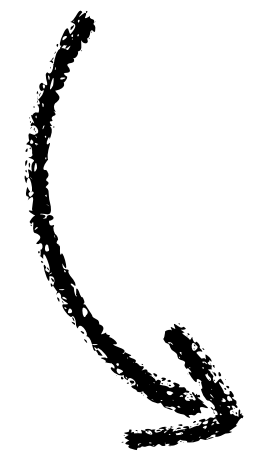
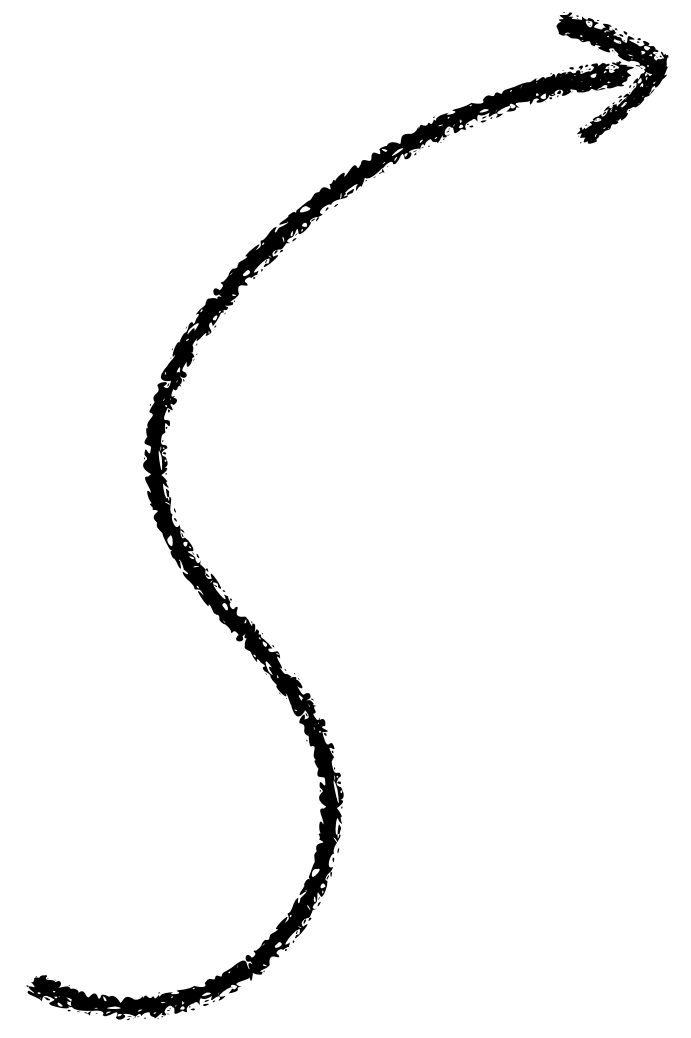
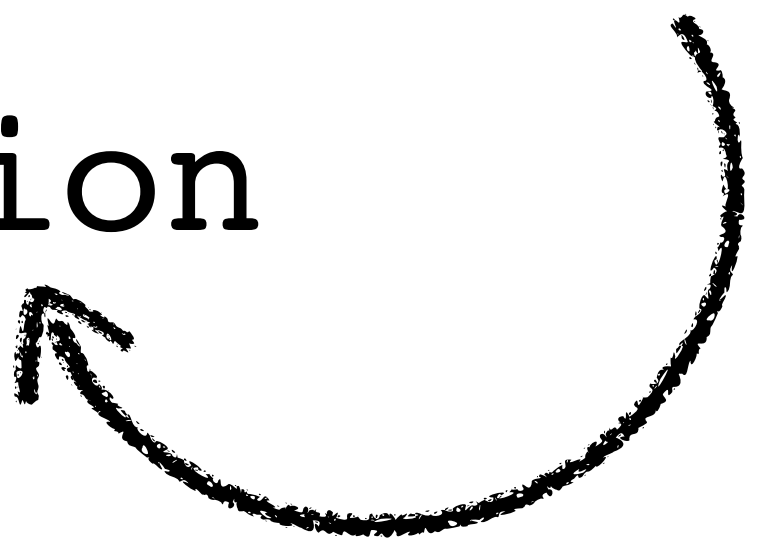
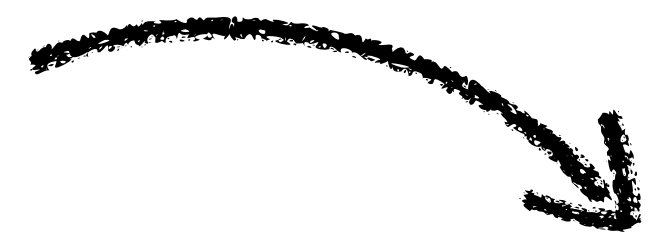
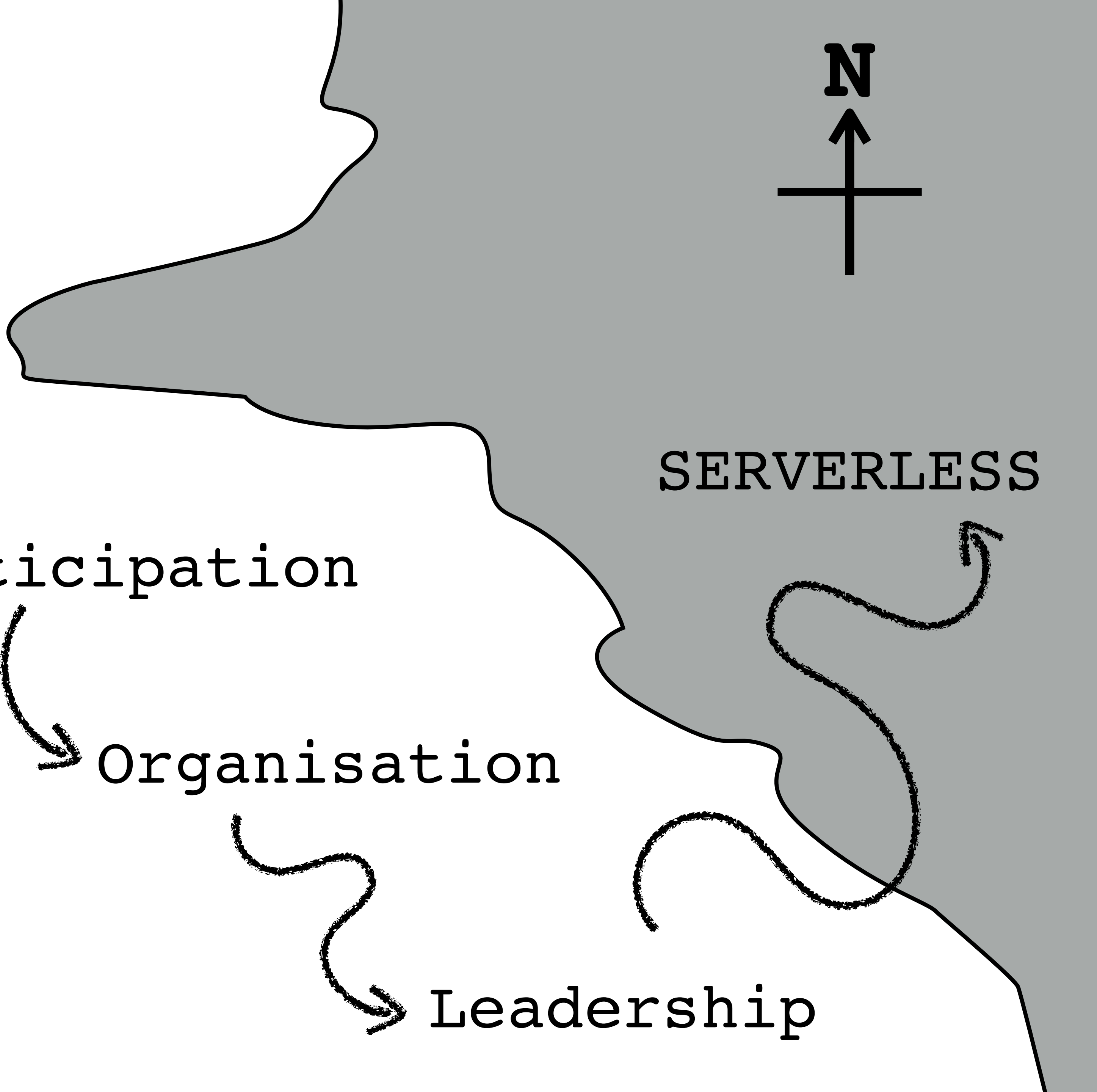
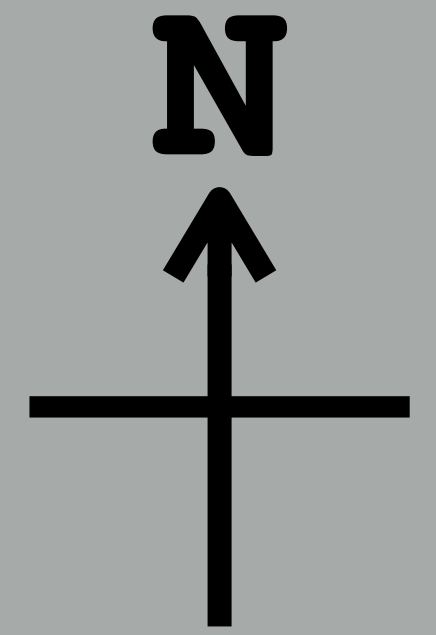

[MEDIUM.COM/WARDLEYSMAPS](https://medium.com/wardleymaps)



GALLIA ANTIQUA.

OCEANUS

ALLICUS

ITALIA

U S



"Crossing the river by feeling the stones"

Deng Xiaoping

Thank you

@swardley

medium.com/wardleymaps

leadingedgeforum.com

simon.wardley@leadingedgeforum.com